



SolaX Power Network Technology (Zhejiang) Co., Ltd.

ADD.: No. 278, Shizhu Road, Chengnan Sub-district, Tonglu
County, Hangzhou, Zhejiang, China
E-mail: info@solaxpower.com

Copyright © SolaX Power Network Technology (Zhejiang) Co., Ltd. All rights reserved.



320101081303

X1-Fit-G4

3.7 kW / 5.0 kW / 6.0kW / 7.5kW

Installation Manual

Version 3.0

www.solaxpower.com



eManual in the QR code or
at <http://nb.solaxpower.com/>

Change History

Changes between document versions are cumulative. The latest version contains all updates made in previous versions.

Version 03 (Aug.01, 2024)

Updated 6.6 Monitoring Connection (Modified WiFi+Lan Mode)

Version 02 (Dec.25, 2023)

Updated 6.6 Monitoring Connection (Modified WiFi+Lan Mode)

Updated 8.3 LCD Operation (Added TOU mode)

Version 01 (Nov.15, 2023)

Updated 8.1 Control Panel (Added the description about idle state)

Version 00 (Sep.20, 2023)

Initial release

Contents

1 Note on this Manual.....	03
1.1 Scope of Validity.....	03
1.2 Target Group.....	03
1.3 Symbols Used.....	03
2 Safety	04
2.1 Important Safety Instructions.....	04
2.2 Explanation of Symbols.....	08
2.3 EC Directives.....	10
3 Introduction	11
3.1 Basic Features.....	11
3.2 Electrical Block Diagram of The System.....	11
3.3 Work Modes.....	14
3.4 Micro Grid.....	18
3.5 Dimension.....	20
3.6 Terminals of Inverter.....	20
4 Technical Data	22
4.1 AC Output/Input.....	22
4.2 Battery.....	22
4.3 Efficiency, Safety and Protection.....	23
4.4 EPS(Off-grid) Output.....	23
4.5 General Data.....	24
5 Installation	25
5.1 Check for Transport Damage.....	25
5.2 Packing List.....	25
5.3 Installation Precautions.....	27
5.4 Tool Preparation.....	28
5.5 Installation Site Conditions.....	30
5.5.1 Installation Carrier Requirements.....	30
5.5.2 Installation Requirements.....	30
5.5.3 Installation Space Requirements.....	31
5.6 Mounting.....	32

6 Electrical Connections.....35

6.1 Grid Port and EPS(Off-grid) Output Connection.....35

6.2 EPS(Off-grid) Block Diagram.....36

6.3 Battery Connection.....44

6.4 Communication Connection.....48

6.4.1 Introduction to DRM Communication.....48

6.4.2 Introduction to Meter/CT Communication.....49

6.4.3 Parallel Connection.....53

6.4.4 COM Communication.....58

6.4.5 Communication Connection Steps.....60

6.5 Grounding Connection (Mandatory).....65

6.6 Monitoring Connection (Accessories).....67

6.7 Check All Below Steps Before Starting Inverter.....69

6.8 Inverter Operation.....70

7 Firmware Upgrading71

8 Setting.....75

8.1 Control Panel.....75

8.2 Menu Structure.....76

8.3 LCD Operation.....77

9 Troubleshooting107

9.1 Troubleshooting.....107

9.2 Routine Maintenance.....113

10 Decommissioning.....114

10.1 Disassemble the Inverter.....114

10.2 Packaging.....114

10.3 Storage and Transportation.....114

10.4 Waste Disposal.....114

11 Disclaimer.....115

*** Warranty Registration Form**

1 Notes on this Manual

1.1 Scope of Validity

This manual is an integral part of X1-Fit G4, It describes the assembly, installation, commissioning, maintenance and failure of the product. Please read it carefully before operating.

X1-Fit -3.7-W	X1-Fit -5.0-W X1-Fit -5.0K-W	X1-Fit -6.0-W	X1-Fit -7.5-W
X1-Fit -3.7-M	X1-Fit -5.0-M	X1-Fit -6.0-M	X1-Fit -7.5-M

Note: "X1-Fit G4" Series refers to the energy storage inverter that supports grid-connected.

"3.7" means 3.7kW, as well as 5.0, 6.0, 7.5.

"5.0K-W" is in compliance with C10/11.

"W" means that Matebox cannot be connected externally, and "M" means that Mate box can be connected externally for EPS operation with full load.

Keep this manual available at any time.

1.2 Target Group

This manual is for qualified electricians. The tasks described in this manual can only be performed by qualified electricians.

1.3 Symbols Used

The following types of safety instructions and general information appear in this document as described below:



Danger!

"Danger" refers to a dangerous situation that, if not avoided, will result in a high level of risk such as serious injury or even death.



Warning!

"Warning" indicates a hazardous situation which, if not avoided, could result in serious injury or death.



Caution!

"Caution" indicates a hazardous situation which, if not avoided, could result in minor or moderate injury.



Notice!

"Notice" provides tips that are valuable for the optimal operation of our product.

2 Safety

2.1 Important Safety Instructions



Danger!

Danger to life due to high voltages in the inverter!

The personnel responsible for the installation, electrical connection, debugging, maintenance and fault handling operation of this product need to be trained, master the correct operation method, have the corresponding electrician qualification and safety operation knowledge.



Caution!

When the inverter is working, it is strictly forbidden to touch the shell. The temperature of the shell can be high and there is a risk of scalding.



Caution!

Radiation may be harmful to health!

Do not stay for a long time and keep at least 20 cm away from the inverter.



Warning!

Authorized service personnel must disconnect the AC and DC power supply of the inverter before performing any maintenance, cleaning or operation of any circuit connected to the inverter.



Warning!

The inverter can not be operated when it is running.



Warning!

Risk of electric shock!

Strictly follow relevant safety specifications for product installation and testing. During installation, operation or maintenance, please read carefully and follow the instructions and precautions on the inverter or user manual. If the operation is incorrect, it may cause personal and property losses. Please keep the user manual properly after use.

This inverter can only use the accessories sold and recommended by us, otherwise it may cause fire, electric shock or casualties. Without the authorization of our company, you may not open the inverter cover or replace the inverter parts, otherwise the warranty promise of the inverter will be invalid.

The use and operation of the inverter must be carried out in accordance with the instructions in this manual, otherwise this protection will fail and the warranty of the inverter will also fail. During working, the inverter surface temperature may exceed 60°C, please make sure the inverter cools down before touching, and make sure children can not touch.

AC power sources must be disconnected from the inverter for at least 5 minutes before any wiring or electrical operation is performed on the inverter to ensure complete isolation of the inverter and avoid electric shock.

Installation position should be away from wet environment and corrosive substances.

Use a multimeter (impedance at least 1 Mohm) to measure the voltage between the UDC+ and the UDC- to ensure that the inverter port is discharged below the safe voltage before starting operation (35VDC).

Direct or indirect lightning strikes can cause failures. Surge is the main cause of lightning damage to most devices. Surge voltage may occur at AC output, especially in remote mountain areas where long distance cable is supplied.

Please consult professionals before installing SPDs.

The external lightning protection device can reduce the influence of direct lightning strike, and the lightning protection device can release surge current to the earth.

If the building installed with external light protection device is far away from the inverter location, in order to protect the inverter from electrical and mechanical damage, the inverter should also install an external lightning protection equipment.

In order to protect the AC system, the level 2 surge protection equipment should be installed at the AC output, located between the inverter and the grid. Installation requirements must comply with IEC61643-21 standard.

➤ Anti-Islanding Effect

The islanding effect means that when the power grid is cut off, the grid-connected power generation system fails to detect the power outage and still supplies power to the power grid. This is very dangerous for the maintenance personnel and the power grid on the transmission line.

This inverter use active frequency offset method to prevent islanding effect.

➤ PE Connection and Leakage Current

- All inverter's incorporate a certified internal Residual Current Monitoring (RCM) in order to protect against possible electrocution and fire hazard in case of a malfunction in the cables or inverter.

There are 2 trip thresholds for the RCM as required for certification (IEC 62109-2:2011).

The default value for electrocution protection is 30 mA, and for slow rising current is 300 mA.

- If an external RCD is required by local regulations, it is recommended to choose a Type-A RCD with the rating residual current of 300 mA. RCD of



Warning!

High leakage Current!
Earth connection essential before connecting supply.

- A faulty ground connection can result in equipment failure, personal and death injuries, and electromagnetic interference.
- Ensure correct according to grounding to IEC62109 and conductor diameter according to STANDARD specification.
- Do not connect the grounding end of the equipment in series to prevent multi-point grounding.
- Electrical appliances must be installed in accordance with the wiring rules of each country.

For United Kingdom

- The installation that connects the equipment to the supply terminals shall comply with the requirements of BS 7671.
- All protective devices cannot be changed.
- User shall ensure that equipment is so installed, designed and operated to maintain at all times compliance with the requirements of ESQCR22(1)(a).

➤ Battery Safety Instructions



This inverter should pair with high voltage battery, for the specific parameters such as battery type, nominal voltage and nominal capacity etc., please refer to section 4.2.

Please refer to the matching battery specification for details.





2.2 Explanation of Symbols







This section gives an explanation of all the symbols shown on the inverter and on the type label.

- Symbols on the Inverter

Symbols	Explanation
	Operating Display
	Battery status
	Fault indicator

- Symbols on the Type Label

Symbols	Explanation
	CE mark. The inverter complies with the requirements of the applicable CE guidelines.
	TUV certified.
	RCM remark.
	Observe enclosed documentation.

	Beware of hot surface. The inverter can become hot during operation. Avoid contact during operation.
	Danger of high voltages. Danger to life due to high voltages in the inverter!
	Danger. Risk of electric shock!
	The inverter can not be disposed together with the household waste. Disposal information can be found in the enclosed documentation.
	Do not operate this inverter until it is isolated from battery and mains.
	Danger to life due to high voltage. There is residual voltage existing in the inverter after powering off, which needs 5 min to discharge. Wait 5 min before you open the upper lid or the DC lid.

2.3 EC Directives

This section describes the requirements of the European low voltage regulations, including safety instructions and system licensing conditions, the user must comply with these regulations when installing, operating, and maintaining the inverter, otherwise personal injury or death may occur, and the inverter will be damaged.

Please read the manual carefully when operating the inverter. If you do not understand "Danger", "Warning", "Caution" and the description in the manual, please contact the manufacturer or service agent before installing and operating the inverter.

Make sure that the whole system complies with the requirements of EC(2014/35/EU, 2014/30/EU, etc.) before starting the module (i.e. to start the operation).

Standard of 2014/35/EU (LVD)
EN IEC 62109-1; EN IEC 62109-2
EN 62477-1

Standard of 2014/30/EU (EMC)
EN IEC 61000-6-1; EN IEC 61000-6-2;
EN IEC 61000-6-3; EN IEC 61000-6-4;
EN IEC 61000-3-2; EN 61000-3-3;
EN IEC 61000-3-11; EN 61000-3-12
EN 55011

The assembly shall be installed in accordance with the statutory wiring rules. Install and configure the system in accordance with safety rules, including the use of specified wiring methods. The installation of the system can only be done by professional assemblers who are familiar with safety requirements and EMC. The assembler shall ensure that the system complies with the relevant national laws. The individual subassembly of the system shall be interconnected by means of the wiring methods outlined in national/international such as the national electric code (NFPA) No. 70 or VDE regulation 4105.

3 Introduction

3.1 Basic Features

The Series inverter is a high-quality inverter which can store energy into battery.

The inverter can be used to optimize self consumption, store in the battery for future use or feed-in to public grid. Work mode depends on the battery and user's preference. It can provide power for emergency use during the grid lost by using the energy from battery.

3.2 Electrical Block Diagram of The System

The series inverter are designed to have four EPS(Off-grid) wiring schemes, customers can choose EPS(Off-grid) compatible parts Load and EPS(Off-grid) compatible with all load use. There are different ways of wiring in different countries, one is to connect N line with PE line, the other is to separate the line from the PE line wiring, see below;

Diagram A: Neutral line and PE line are separated from each other, and the common load is connected to the EPS(Off-grid) port; (For most countries)

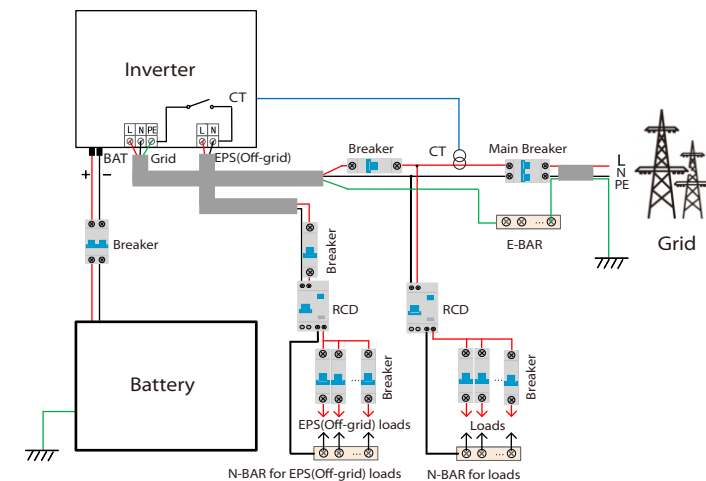

Diagram B: Neutral line and PE line are separated from each other, all loads connect to the EPS(Off-grid) port; (For most countries)

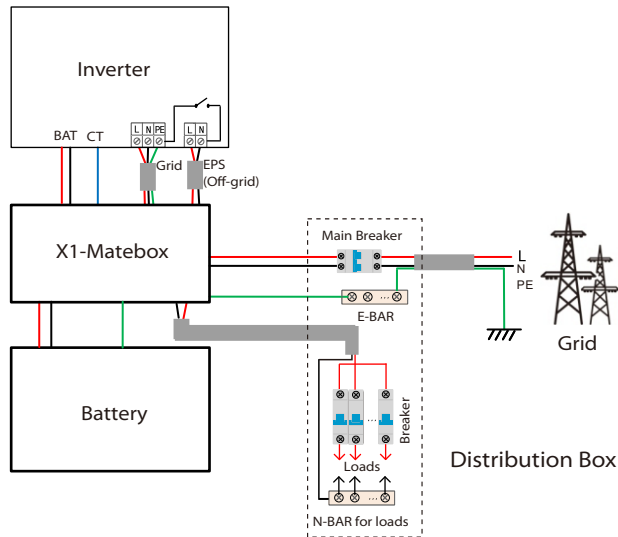

Diagram C: Neutral line and PE line are combined together, and the common load is connected to the EPS(Off-grid) port;(Apply to Australia)

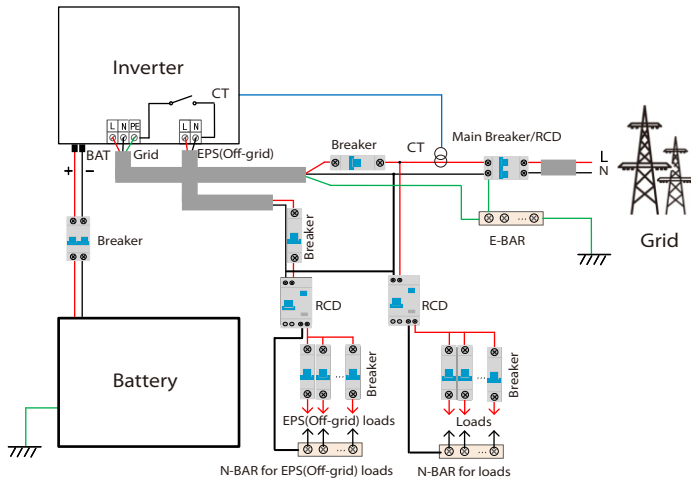
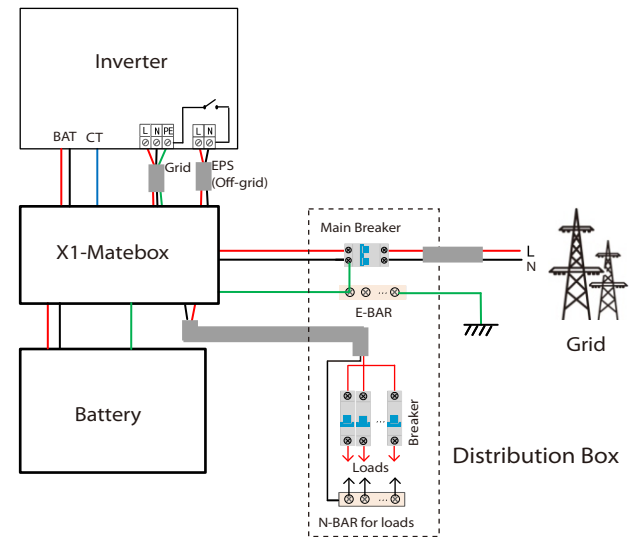

Diagram D: Neutral line and PE line are combined together, all loads connect to the EPS(Off-grid) port; (Apply to Australia)



X1-Matebox is a convenient wiring and accessory that can realize EPS full load. For more information, please refer to X1-Matebox. If you need to buy X1-Matebox, please contact us.

Notice!

- When power cuts suddenly, the inverter connects the N line of EPS(Off-grid) load with the ground through relay, providing a fixed zero potential for EPS(Off-grid) load and ensuring the safety of electricity use by users.
- Please control the inverter load and make sure it is "output value" in "within" EPS(Off-grid) mode, otherwise the inverter will stop and alarm overload fault".
- Please confirm with the grid operator whether there are special regulations for grid connection.

3.3 Work Modes (With Grid-tied Inverter)

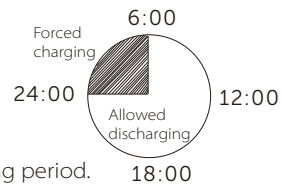

The inverter has two settable working periods: allowed discharging period and forced charging period.

For how to set the two working periods, please refer to page 92.

The default value of allowed discharging period is 00:00~23:59, and the default value of forced charging period is 00:00~00:00 (closed in default).

You can set the two working periods by yourself.

As shown in the example above, the allowed discharging period is 6 am to 24 pm, and the forced charging period is 24 pm to 6 am.

• Forced charging period

The priority of forced charging period is higher than all work modes.

Under the forced charging period, the inverter will charge the battery first until the battery SOC reaches the value of "charge battery to".

• Allowed discharging period

Under the allowed discharging period, the inverter will allow the battery to discharge (but not force the battery to discharge).

The following work modes will take effect under the allowed discharging period.

When **X1-Fit G4 series inverter** matches with **grid-tied inverter**, the following work modes are available.

For **on-grid** status, there are five work modes: Self Use, Feed-in Priority, Backup, Manual and Peak shaving mode.

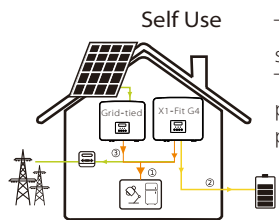

Self Use
The self-use mode is suitable for areas with low feed-in subsidies and high electricity prices. The power of PV will supply the loads first, and surplus power will charge the battery, then the remaining power will feed into the grid.

Priority: Loads > Battery > Grid

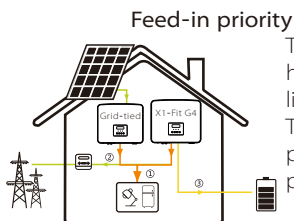

Feed-in priority
The feed-in priority mode is suitable for areas with high feed-in subsidies, but has feed-in power limitation. The power of PV will supply the loads first, and surplus power will feed into the grid, then the remaining power will charge the battery.

Priority: Loads > Grid > Battery

Backup mode

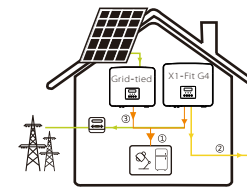

The back-up mode is suitable for areas with frequent power outages. This mode will maintain the battery capacity at a relatively high level, to ensure that the emergency loads can be used when the grid is off. Same working logic with "Self-use" mode.

Priority: Loads > Battery > Grid

* For the above three work modes, when the power of PV is insufficient to supply the loads, the battery will supply the loads. If the battery is insufficient, then the grid will supply the loads.

Manual

This work mode is for the after-sales team to do after-sales maintenance.

For **off-grid** status, there is only one work mode: EPS (Off-grid).

EPS (Off-grid)

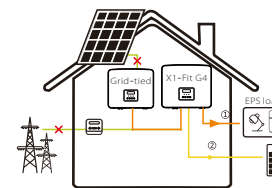

In case of grid outage, the system will supply EPS loads through battery. (The battery must be installed, and EPS loads shall not exceed battery's max. output power.)

Priority: Loads > Battery

Note:

The battery will stop discharging when SOC=min SOC. But due to battery self consumption, sometimes SOC may < min SOC.

For on-grid status, if the battery SOC ≤ (min SOC-5%), the inverter will take utility energy to charge battery SOC back to (min SOC+1%).

For off-grid status, if the battery SOC ≤ min SOC, the inverter will be unable to enter EPS mode (the battery will be unable to discharge) unless SOC is back to 31%.

Peak shaving mode

Peak Shaving mode is set for leveling out peaks in electricity use. System is controlled to charge up during off-peak hours and discharged during peak hours.

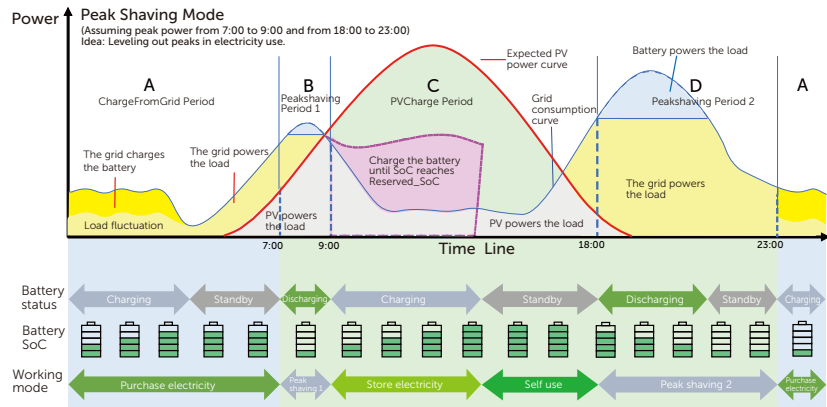

Time period	Battery SOC	Load and peaklimits conditions	Inverter working status
Period A	X	X	Battery charging period during which discharging is not allowed and the PV will charge the battery first for peak shaving.
Period B and D	X	Load < Peaklimits	The PV will charge the battery first. When the battery is fully charged, the PV will supply power for loads, and the surplus power will feed into the grid.
	X	Load > Peaklimits	The PV and battery will discharge energy for loads and thus reduce the amount of energy purchased from the grid.
Period C	X	X	The battery does not discharge. The PV will charge the battery to the "Reserved SOC" first and then supply power for loads, with the surplus power feeding into the grid. Charging the battery first in these periods is storing energy for the peak shaving.

Note:
 PeakLimits (W): The load consumption from grid side.
 Reserved SOC (%): Refers to the lower limit of SoC required for later peak shaving period. The default value is 50%. The adjustment range is 10~100%.
 X: Not applicable.

TOU mode

In the TOU mode, different working modes, i.e Self-use, Charging, Discharging, Peaking shaving and Battery off can be set for different time periods in accordance with actual needs and environment conditions through SolaX Cloud App or Web.

The day can be divided into up to 10 time slots, and the minimum time slot is 15 minutes, independent working mode can be set for each time slot. Please refer to Web Guide or App Guide for details about how to set the TOU mode.

Time Slot	Working Mode
X:XX~X:XX e.g 0:00~0:15	Choose one work mode from Self-use / Charging / Discharging / Battery off / Peaking shaving

Note:
 Self-use: Same working logic with "Self-use Mode", but it is not limited by the charging and discharging time slots. The priority of PV: Loads > Battery > Grid.

Charging: The power of PV will charge the battery as much as possible to the set SOC of Charge BAT to (%). You can set whether to Charge from grid. The default value of Charge BAT to (%) is 100%. When the battery reaches the set SOC, the surplus power will perform "Self-use Mode" or supply to the grid (based on the system setup), at this point, Charge from grid is not allowed.

Discharging: If allowed by the battery, the system outputs a specified power from the grid based on the set output percentage, controlling the power at the AC port. You need to set the RatePower (%) through Web or App when choosing Discharging mode. When the battery Discharge to (%) reaches the set SOC, the inverter performs "Self-use Mode".

Peak shaving: The working logic is that when the power consumption from the grid exceeds the set PeakLimit value, the battery is allowed to discharge power. The excess power beyond the limit is provided by the combination of photovoltaic and battery to ensure that the maximum power purchased from the grid does not exceed the set limit. You need to set the PeakLimit value through Web or App when choosing Peak shaving mode.

Battery off: The battery neither charges nor discharges. The power of PV will supply to loads or the grid. Only when the battery SOC is lower than the system (TOU) Min SOC, the battery can be charged.

3.4 Micro Grid

Introduction

There are a large number of traditional on-grid inverters on the market. Due to Islanding Effect, on-grid inverters are unable to work during off-grid. This feature makes users lose the on-grid inverter PV energy when off-grid.

Micro-grid is a function that makes hybrid inverter simulate the grid to active on-grid inverter during off-grid. By connecting on-grid inverter to the EPS port of hybrid inverter, hybrid inverter is able to use PV or battery energy to active on-grid inverter when utility lost.

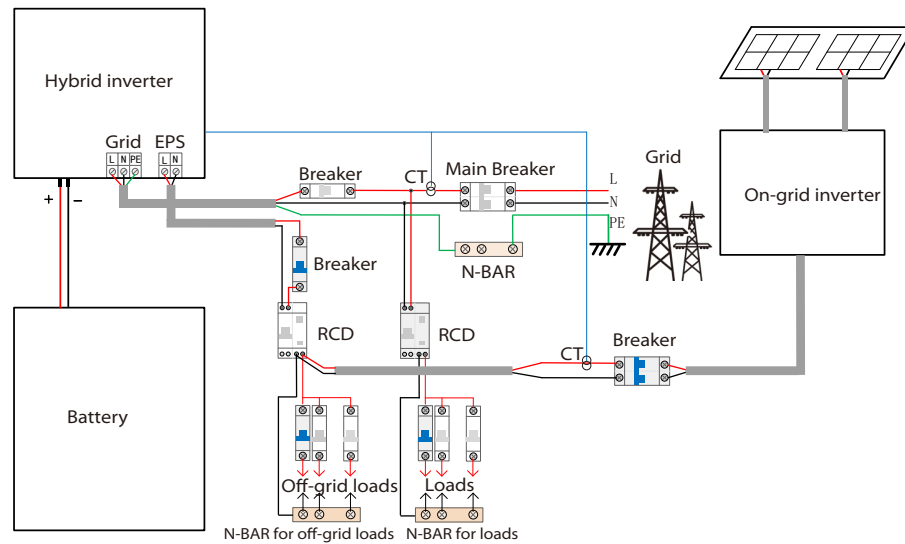

Configuration

1. Strictly follow the above wiring diagram.
2. Enable: "Settings" → "Advanced settings" → "MicroGrid".

Compatibility

Hybrid Inverter: Fit can not be used in pure off-grid environment
On-grid inverter: Any brand on-grid inverter that supports "Response to an Increase in Frequency".

On-grid inverter output power ≤ Max hybrid inverter EPS output power
On-grid inverter output power ≤ Max battery charging power

Battery Quantity	1	2	3	4
On-grid Inverter power upper limitation for T-BAT-5.8	3.0 kW	6.0 kW	7.5 kW	Unsupported
On-grid Inverter power upper limitation for T-BAT-3.0	3.0 kW	6.0 kW	7.5 kW	7.5 kW

Note :

Since hybrid inverter is unable to control on-grid inverter, therefore hybrid inverter can not achieve zero injection when loads power + battery charging power < on-grid inverter output power.

3.5 Dimension

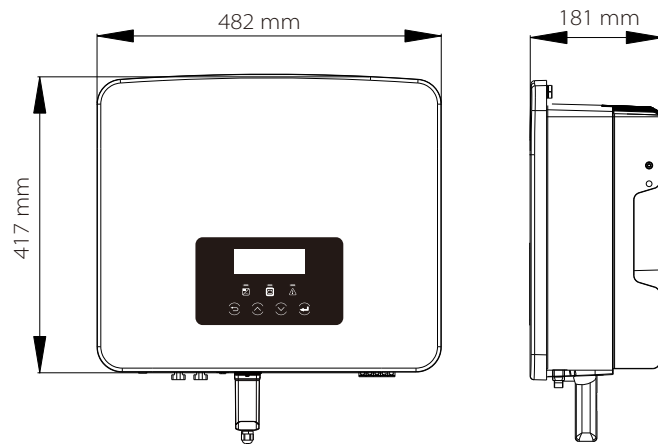

3.6 Terminals of Inverter

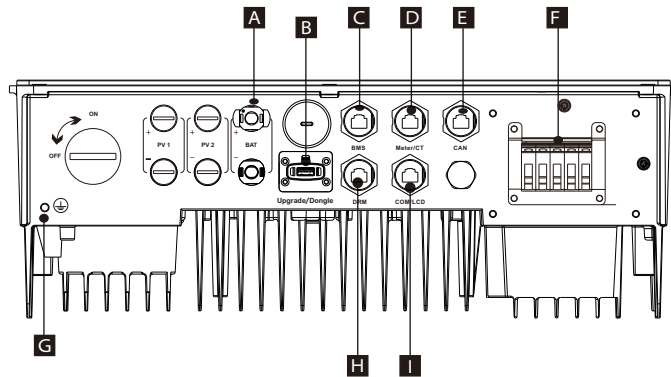

Object	Description
A	Battery connection port
B	USB port for upgrading/External monitoring connection port
C	Battery communication
D	Meter/CT Port
E	Communication port for parallel operation
F	Load/EPS Output
G	Ground connection port
H	DRM Port(only for Australia)
I	Communications/ LCD external screen ports



Warning!

Qualified electrician required for the installation.

4 Technical Data

4.1 AC Output/Input

Model	X1-Fit-3.7-W	X1-Fit-5.0-W	X1-Fit-6.0-W	X1-Fit-7.5-W
	X1-Fit-3.7-M	X1-Fit-5.0K-W X1-Fit-5.0-M	X1-Fit-6.0-M	X1-Fit-7.5-M
AC Output				
Rated Output Apparent Power [VA]	3680	5000 (Germany 4600, AU 4999) (5.0K-W 4999)	6000	7500
Max. Output Apparent Power [VA]	3680	5500 (Germany 4600, AU 4999) (5.0K-W 4999)	6600	7500
Nominal AC voltage [a.c. V]	220/230/240 (180 to 270)			
Frequency [Hz]	50/60			
Rated Output Current [a.c. A]	16	21.7	26.1	32.6
Max. Output Continuous Current [a.c. A]	16	23.9 (Germany 20, AU 21.7)	28.6	32.6
Current (inrush) (at 50µs) [a.c. A]	10			
Maximum output fault current (at 1ms) [a.c. A]	91			
Maximum output overcurrent protection [a.c. A]	65			
Power factor range	0.8 leading - 0.8 lagging			
Total harmonic distortion(THDi)	< 2%			
AC Input				
Max. apparent power [VA]	7360	9200	9200	9200
Rated AC power [W]	3680	5000	6000	7500
Rated grid voltage(range)[a.c. V]	220/230/240 (180 to 270)			
Rated grid frequency [Hz]	50/60			
Max. AC current [a.c. A]	32	40	40	40
Power factor range	0.8 leading - 0.8 lagging			

4.2 Battery

Model	X1-Fit-3.7-W	X1-Fit-5.0-W	X1-Fit-6.0-W	X1-Fit-7.5-W
	X1-Fit-3.7-M	X1-Fit-5.0K-W X1-Fit-5.0-M	X1-Fit-6.0-M	X1-Fit-7.5-M
Battery type	Lithium batteries			
Battery voltage range [d.c. V]	80-480			
Max. continuous charge/discharge current [d.c. A]	30A			
Communication interface	CAN/RS485			
Reverse connection protection	Yes			

4.3 Efficiency, Safety and Protection

Model	X1-Fit-3.7-W	X1-Fit-5.0-W	X1-Fit-6.0-W	X1-Fit-7.5-W
	X1-Fit-3.7-M	X1-Fit-5.0K-W X1-Fit-5.0-M	X1-Fit-6.0-M	X1-Fit-7.5-M
Max. battery charge efficiency (AC to BAT)(@ full load)	97.0%	97.0%	97.0%	97.0%
Max. battery discharge efficiency (BAT to AC)(@ full load)	97.0%	97.0%	97.0%	97.0%
Safety				
Safety	EN/IEC 62109-1/-2			
Grid Monitoring	VDE-AR-N 4105, G99, G98, AS/NZS 4777, EN50549, CEI 0-21, C10/11, IEC61727, RD1699, NRS 097-2-1, PEA/MEA, VFR2019, PPDS			
AC SPD Protection	Integrated(Typelll)			
Over/under voltage protection	YES			
Grid protection	YES			
DC injection monitoring	YES			
Back feed current monitoring	YES			
Residual current detection	YES			
Active anti-islanding method	Frequency Shift			
Overload protection	YES			
Overheat protection	YES			

4.4 EPS(Off-grid) Output

Model	X1-Fit-3.7-W	X1-Fit-5.0-W	X1-Fit-6.0-W	X1-Fit-7.5-W
	X1-Fit-3.7-M	X1-Fit-5.0K-W X1-Fit-5.0-M	X1-Fit-6.0-M	X1-Fit-7.5-M
Rated EPS Apparent Power [VA]	3680	5000	6000	7500
Nominal EPS Voltage [a.c. V]	230VAC			
Frequency [Hz]	50/60			
Rated EPS Current [a.c. A]	16	21.7	26.1	32.6
EPS Peak Power [VA]	6000,10s	7000,10s	9000,10s	11250,10s
Switching time [ms]	internal switch<10,external switch<100			
Total harmonic distortion (THDv)	<2%			

3.5 Generic Data

Model	X1-Fit -3.7-W	X1-Fit-5.0-W	X1-Fit -6.0-W	X1-Fit -7.5-W
	X1-Fit -3.7-M	X1-Fit-5.0K-W X1-Fit-5.0-M	X1-Fit -6.0-M	X1-Fit -7.5-M
Dimensions [W/H/D](mm)	482*417*181			
Packing size [W/H/D](mm)	590*530*315			
Net weight [kg]	23	23	23	23
Gross weight [kg]	27	27	27	28
Heat dissipation treatment	Natural Cooling			Smart Cooling
Noise emission(typical)[dB]	<30			<45
Storage temperature range [°C]	-40 to +65			
Operating ambient temperature range [°C]	-35 to +60 (derating at 45)			
Humidity [%]	0% to 100% (no condensation)			
Altitude [m]	<3000			
Ingress protection	IP65			
Protective class	I			
Night consumption	<3W			
Overvoltage category	III (MAINS),II (Battery)			
Pollution degree	III			
Installation mode	Wall mounted			
Inverter topology	Non-isolated			
Communication interface	Meter/CT, external control RS485, Pocket series, DRM, USB,CAN			

5 Installation

5.1 Check for Transport Damage

Ensure that the inverter is in good condition via transportation. If there is any visible damage such as cracks, please contact the dealer immediately.

5.2 Packing List

Open the package and check the materials and accessories according to the following list.



M series

Item	Description	Quantity
/	Inverter	1 pc
/	Bracket	1 pc
A	Self-tapping screw	3 pcs
B	Expansion tube	3 pcs
C	Washer	3 pcs
D	Negative Battery connector	1 pc
E	Positive Battery connector	1 pc
F	OT terminal	1 pc
G	M5 inner hexagon bolt	1 pc
H	Waterproof connector with RJ45	4 pcs
I	RJ45 terminal	1 pc
J	Documents	/
/	Dongle (Optional)	1 pc

D series

Item	Description	Quantity
/	Inverter	1 pc
/	Bracket	1 pc
A	Self-tapping screw	3 pcs
B	Expansion tube	3 pcs
C	Washer	3 pcs
D	Negative Battery connector	1 pc
E	Positive Battery connector	1 pc
F	OT terminal	1 pc
G	M5 inner hexagon bolt	1 pc
H	Waterproof connector with RJ45	4 pcs
I	RJ45 terminal	1 pc
J	Documents	/
K	8 mm ² ferrule	3 pcs
L	6 mm ² ferrule	2 pcs
M	RJ45 connector	1 pc
N	CT	1 pc
/	AC protective cover	1 pc
/	Meter (optional)	1 pc
/	CT 2 Kit (optional)	1 pc
/	Dongle (optional)	1 pc

* For the optional accessories, please be subject to the actual delivery.

5.3 Installation Precautions

The protection level of this inverter is IP 65, so that the inverter can be installed outdoors.

Check the installation environment and pay attention to the following conditions when installing:

- Do not expose to strong light.
- Do not touch flammable building materials.
- Do not approach flammable and explosive gases or liquids (e.g. where chemicals are stored).
- Do not touch cold air directly.
- Do not approach TV antenna or cable.
- Do not place in areas above 3000 meters above sea level.
- Do not install in precipitation or high humidity, which may cause corrosion or damage Internal devices.
- Keep the system out of reach of children.

If the inverter is installed in a narrow area, be sure to reserve appropriate space for heat dissipation.



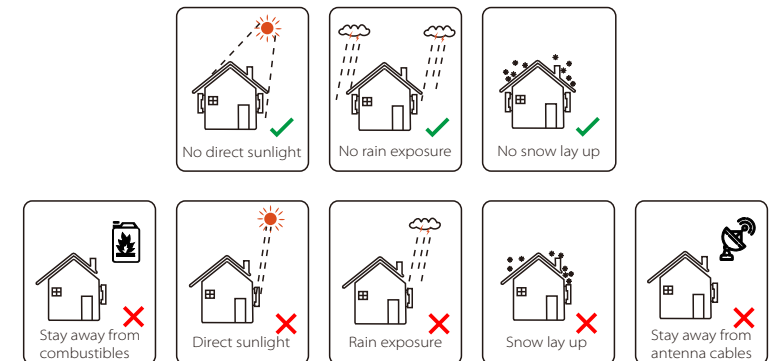

The ambient temperature of the installation site is -35°C~60°C.

The maximum angle range of wall tilt ±5°.







Avoid direct sunlight, rain and snow weather.



5.4 Tool preparation

Tool equipment				
Type	Name	Image	Name	Image
Machine Installation Tools	Hammer drill	Bit $\Phi 10$ 	Multimeter	DC Voltage Range ≥ 1100 V.DC 
	Torque screwdriver	Crosshead M5 	Socket wrench set (Hexagon)	
	OT terminals press clamp	$0.5 \text{ mm}^2 \sim 6 \text{ mm}^2$ 	Diagonal pliers	
	Utility knife		Multifunction terminal crimping tool (RJ45)	
	Diagonal pliers		Marker	
	Rubber hammer		Tape measure	
	Crimping Tool		Hexagon keys	
	European terminal crimping tool		Spirit level	
Individual Protection Tools	Dustproof Cover		Protective glasses	

Tool equipment				
Type	Name	Image	Name	Image
Individual Protection Tool	Safety gloves		Safety shoes	

Type	Name	Image	Requirement
Equipment Preparation	Breaker		Grid port and EPS(Off-grid) port wiring section
Cable Preparation	EPS(Off-grid) end wire		Double Core Cables
	Grid end wire		Triple Core Cables
	Communication lines		Twisted pair with shield
	Battery Cable		Conventional wire
	PE Cable		Conventional wire

5.5 Installation Site Conditions

5.5.1 Installation Carrier Requirements

Do not install the inverter near flammable materials.
 Please install the inverter on a solid object that can withstand the weight requirements of the inverter and energy storage system.
 Please be careful not to install the inverter in the plasterboard wall or similar to the residential places with poor sound insulation, so as not to work with noise and interfere with the residents' life in the morning.

5.5.2 Installation Requirements

Install the inverter at a maximum back tilt of 5 degrees, the inverter can not be tilted forward, inverted, excessive back tilted or side tilted.

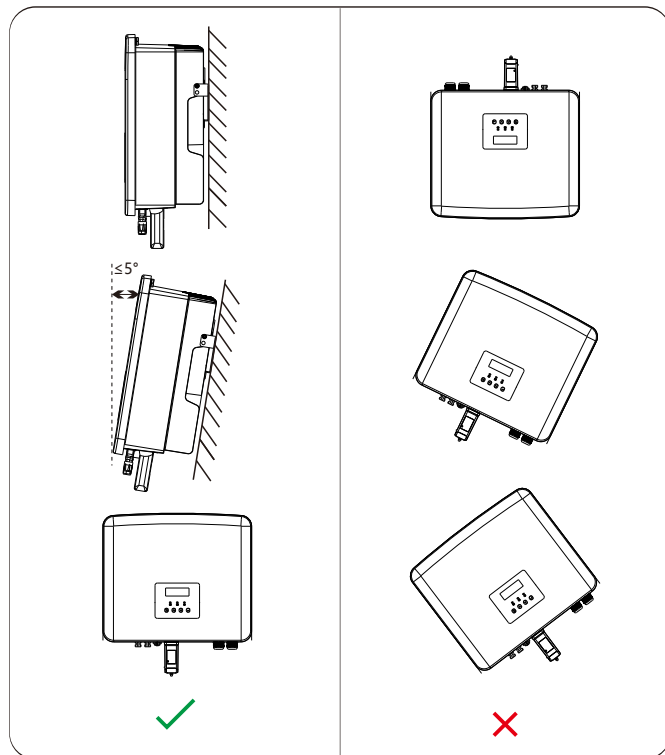

5.5.3 Installation Space Requirements

Reserve enough space when installing inverter (at least 300 mm) for heat dissipation.

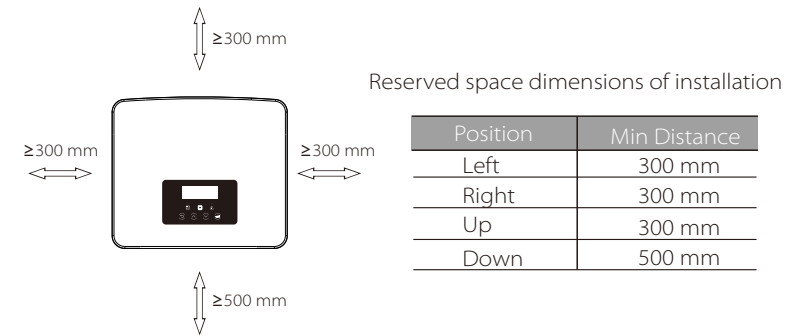

For multi-inverter installation scenarios, the inline installation method is recommended; when the space is insufficient, the recommended method of installation in the form of "products"; it is not recommended to install multiple inverters in stacks. If you choose stack installation, please refer to the installation separation distance below.

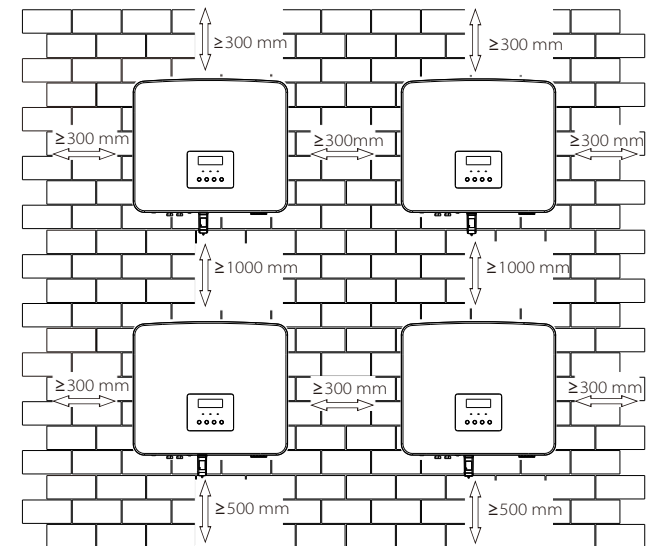

5.6 Mounting

Regarding the installation of M-series inverter, please refer to the X1-

➤ Preparation

Please prepare the following tools before installation.



Installation tools: screwdriver, wrench, $\Phi 10$ drill, rubber hammer, socket wrench set, hexagon keys and spirit level.

➤ Step 1: Fix the wall bracket to the wall

First find the Self-tapping screw (Part A), expansion tube (Part B), Washer (Part C) and the wall bracket in the accessory bag, as shown below:



Expansion tube, Washer, Self-tapping screw Bracket

a) Draw drilling holes as per the bracket's hole locations by a marker, and ensure that the two top holes lie on the same straight line by spirit level.

b) Drill holes at marked spots at depth of 80 mm.

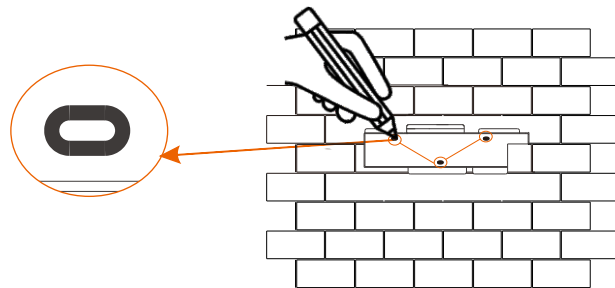

a)

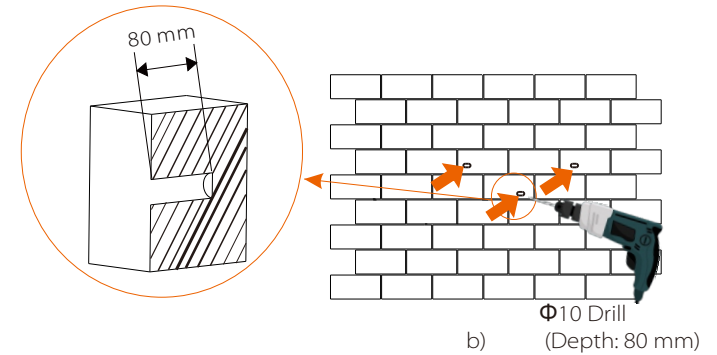

b) $\Phi 10$ Drill (Depth: 80 mm)

➤ Step 2: Hang the inverter on the bracket

c) Insert expansion tubes into the holes, use rubber hammer to knock the expansion tubes into the wall;

d) The bracket is aligned with the screw and use the outer hexagonal wrench to screw the Self-tapping screw until the expansion tube "bang" is heard.

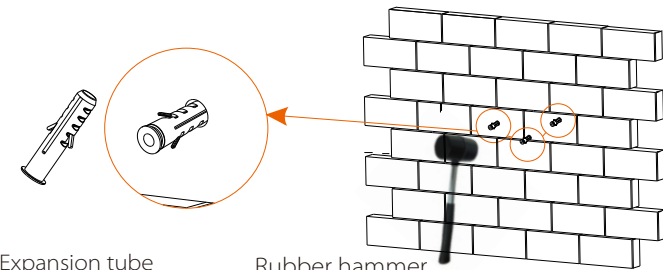

Expansion tube

Rubber hammer

c)

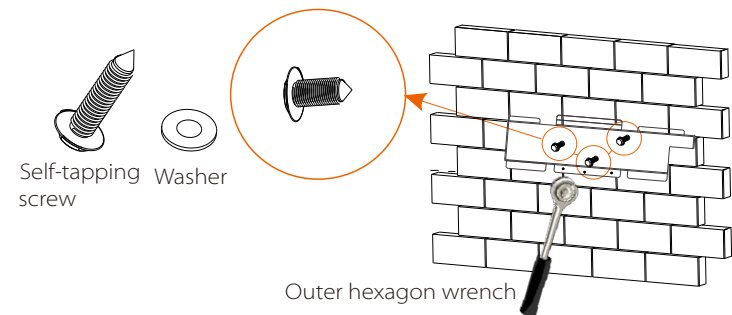

Self-tapping screw Washer

Outer hexagon wrench

d)

➤ Step 3: Tighten the inverter and bracket

- e) Hang the buckle on the inverter to the corresponding position of the backplane;
- f) Use the inner hexagonal wrench to tighten the inner hexagonal screw on

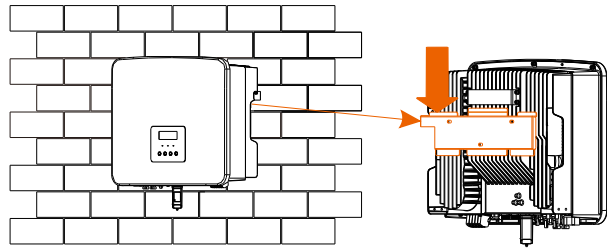

e)

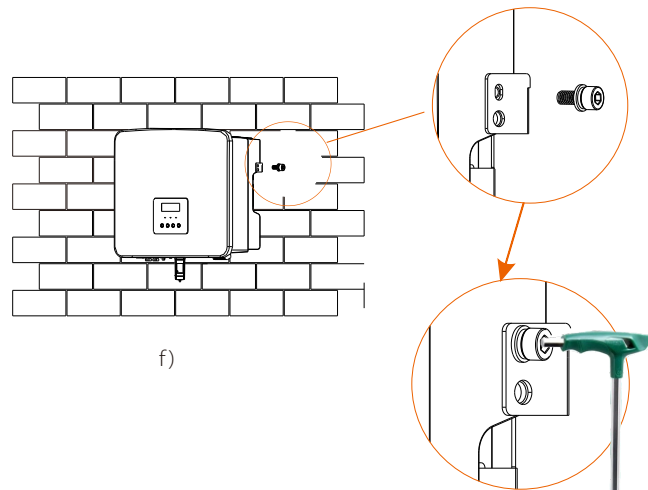

f)

Inner hexagonal wrench
(Torque :1.2±0.1 N·m)

6 Electrical Connections

6.1 Grid Port and EPS(Off-grid) Output Connection

The series inverter are single-phase inverter. Suitable for rated voltage 220/230/240 V, frequency 50/60 Hz. For more technical requirements, please consult the requirements of the local public grid.

➤ Grid port connection

Grid Cable and Micro-breaker recommended

Model	X1-Fit-3.7-W	X1-Fit-5.0-W X1-Fit-5.0K-W	X1-Fit-6.0-W	X1-Fit-7.5-W
Cable (copper)	6-8 mm ²	8-10 mm ²	8-10 mm ²	8-10 mm ²
Micro-Breaker	40 A	50 A	50 A	50 A

Model	X1-Fit-3.7-M	X1-Fit-5.0-M	X1-Fit-6.0-M	X1-Fit-7.5-M
Cable (copper)	3-4 mm ²	4-6 mm ²	4-6 mm ²	6-8 mm ²
Micro-Breaker	25 A	32 A	32 A	40 A

EPS Cable and Micro-breaker recommended

Model	X1-Fit-3.7-W X1-Fit-3.7-M	X1-Fit-5.0-W X1-Fit-5.0K-W X1-Fit-5.0-M	X1-Fit-6.0-W X1-Fit-6.0-M	X1-Fit-7.5-W X1-Fit-7.5-M
Cable (copper)	3-4 mm ²	4-6 mm ²	4-6 mm ²	6-8 mm ²
Micro-Breaker	25 A	32 A	32 A	40 A

The circuit breaker should be installed between the inverter and the mains, and the load should not be directly connected to the inverter.

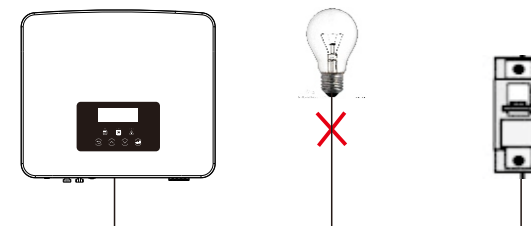

Figure: Wrong connection of load and inverter

6.2 EPS(Off-grid) Block Diagram

The series inverter has an EPS(Off-grid) function. When the grid is connected, the inverter outputs go through the Grid port, and when the grid is disconnected, the inverter outputs go through the EPS(Off-grid) port. The EPS(Off-grid) function can be connected to part of the load, and it can also be used to connect to all loads. Please refer to the following diagram for the wiring .

To be compatible with all loads, you will need an addition a accessory. If you you need a solution, please contact our sales.

➤ EPS(Off-grid) wiring diagram

For to different local wiring rules, please refer to the diagram below. Please select the appropriate wiring method according to local wiring rules.

Diagram A: Neutral line and PE line are separated from each other, and the common load is connected to the EPS(Off-grid) port; (For most countries)

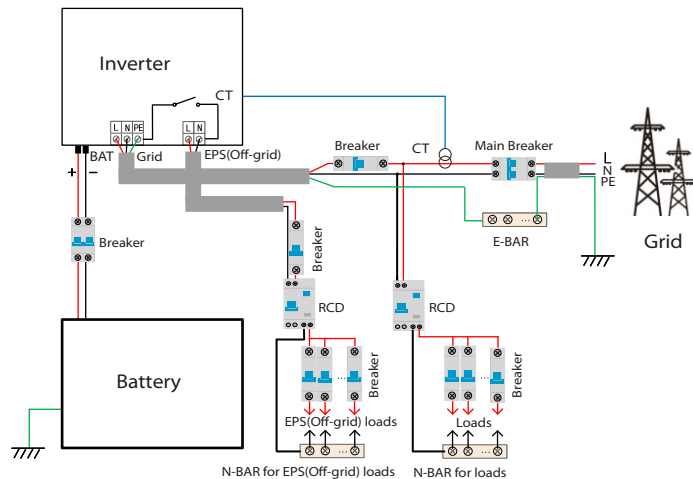

Diagram B: Neutral line and PE line are separated from each other, all loads connect to the EPS(Off-grid) port; (For most countries)

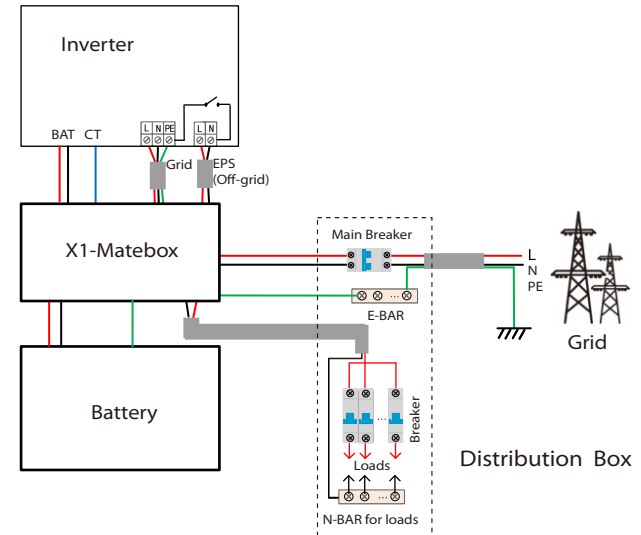

Diagram C: Neutral line and PE line are combined together, and the common load is connected to the EPS(Off-grid) port; (Apply to Australia)

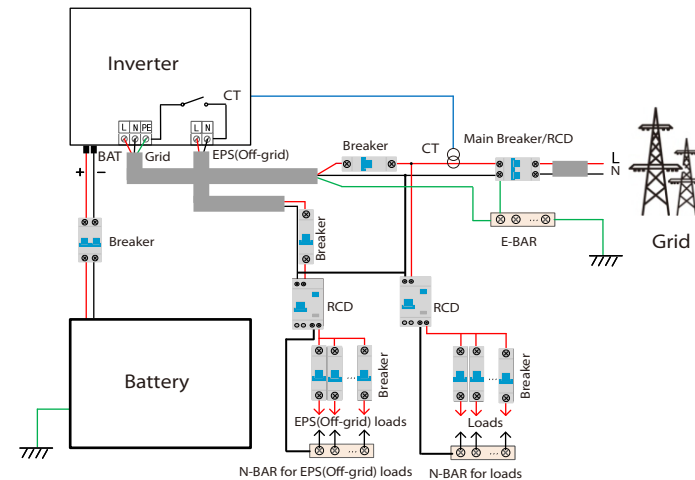
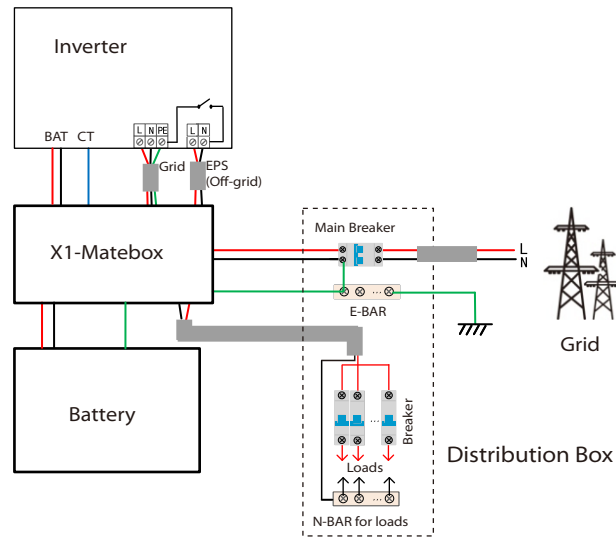

Diagram D: Neutral line and PE line are combined together, all loads connect to the EPS(Off-grid) port; (Apply to Australia)



X1-Matebox is a convenient wiring and accessory that can realize EPS(Off-grid) full load. For more information, please refer to X1-Matebox. If you need to buy X1-Matebox, please contact us.

Notice!

In full load scheme **Diagram B** and **Diagram D**, set "Matebox" to "Enable" under Settings;

The Australian customer must shorten the N lines of the Grid and the EPS(Off-grid) in the X1-Matebox.

If your local wiring method does not follow the above operation guide, especially the neutral wire, ground wire, RCD wire, please contact our company before operation.

➤ EPS(Off-grid) load requirements

Warning!

Ensure that the EPS(Off-grid) load rated power is within the EPS(Off-grid) rated output power range, otherwise, the inverter will report an "overload" warning.

When "overload" occurs, adjust the load power to make sure it is within the EPS(Off-grid) rated output power range, and the inverter will automatically return to normal.

For non-linear loads, ensure that the inrush current power is within the EPS(Off-grid) rated output power range. When the configuration current is less than the maximum DC input current, the capacity and voltage of lithium battery and lead acid battery will decrease linearly.

The following table shows some common loads for your reference.

Notice: Please check with the manufacturer for high-power inductive loads.

Content	Power		Common equipment	Instance		
	Start	Rated		Equipment	Start	Rated
Resistive load	X 1	X 1	 Incandescent lamp	100 W Incandescent lamp	100 VA (W)	100 VA (W)
Inductive load	X 3~5	X 2	 Fan Fridge	150 W Fridge	450 - 750 VA(W)	300 VA (W)

➤ **Grid and EPS(Off-grid) connection steps**

- Connection requirements

Notice: Check the grid voltage and compare the voltage range (see technical data).

Disconnect the circuit board from all power sources to prevent electric shock.

The Grid and the EPS(Off-grid) ports of M series inverter have been connected, for specific installation details, please refer to the X1-Matebox Quick Installation Guide. And the W series needs to be wired according to the following steps.

Step 1. Prepare a Grid cable (three-core wire) and an EPS(Off-grid) cable (two-core wire), and then find the 8 mm² ferrules (Part K) 6 mm² ferrules (Part L) and AC protective cover in the accessory bag.

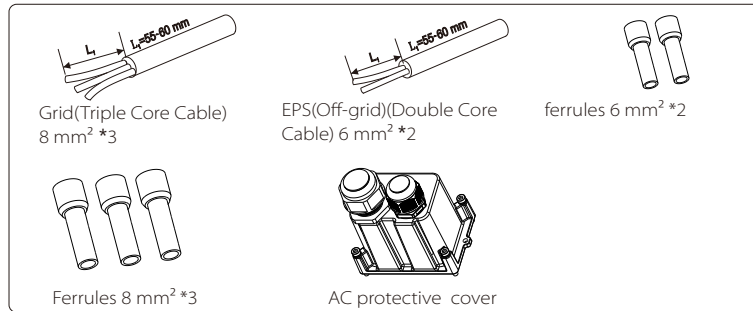

Step 2: The Grid and EPS(Off-grid) cables go through the corresponding Grid and EPS(Off-grid) ports of the AC protective cover.

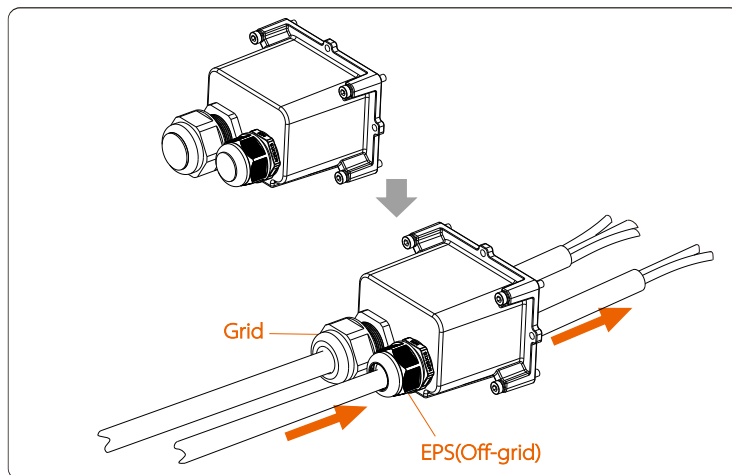

Step 3. Remove the 12 mm insulation layer at the end of the wire. Insert the ferrules respectively, and make sure that the stripped ends are inserted into

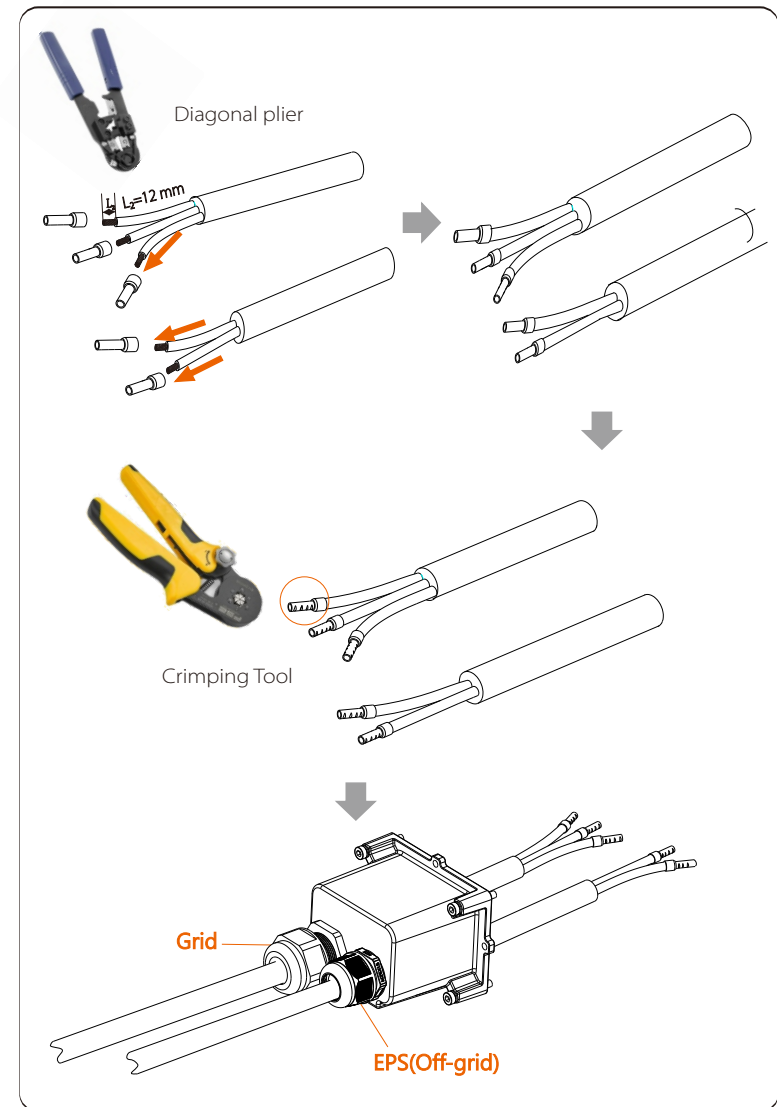

Step 4. Find the location of the AC interface on the inverter, insert the crimped terminals into the UW10 terminals L, N, and P according to the wire sequence, and use a flat-blade screwdriver to tighten the screws. (Torque: $1.5 \pm 0.1 \text{ N} \cdot \text{m}$)

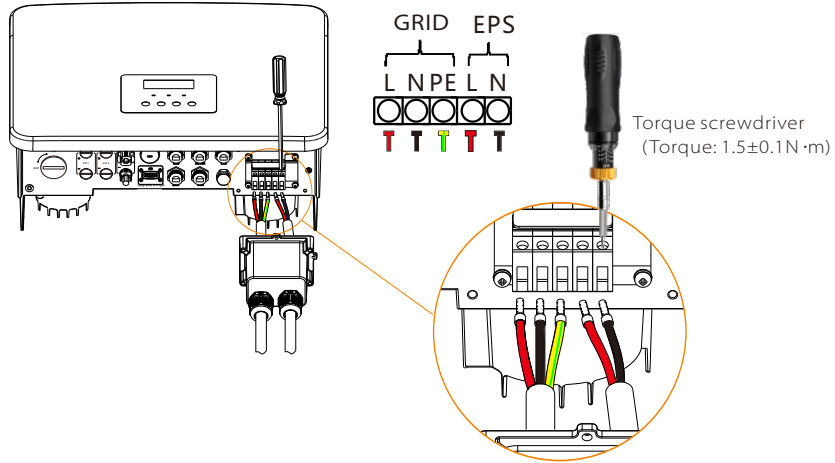

Step 5. Install the AC protective cover and tighten the screws on the four

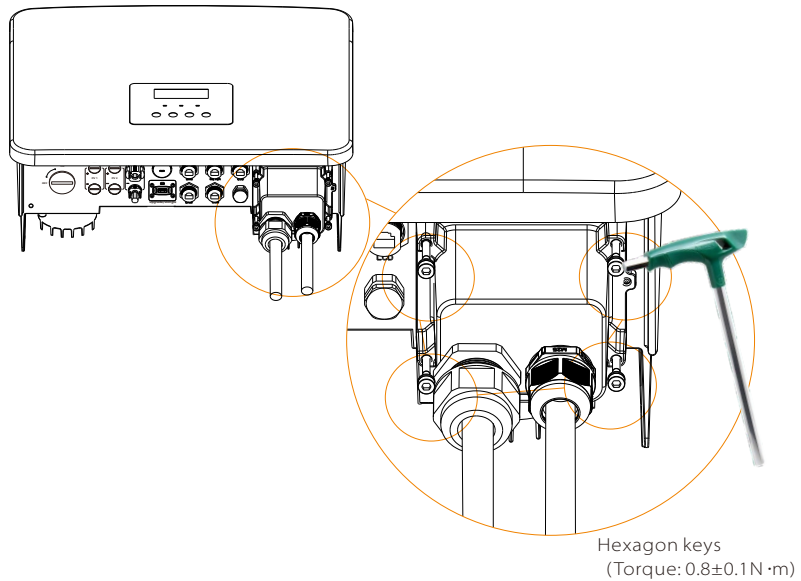

Step 6. Tighten the fastening head.

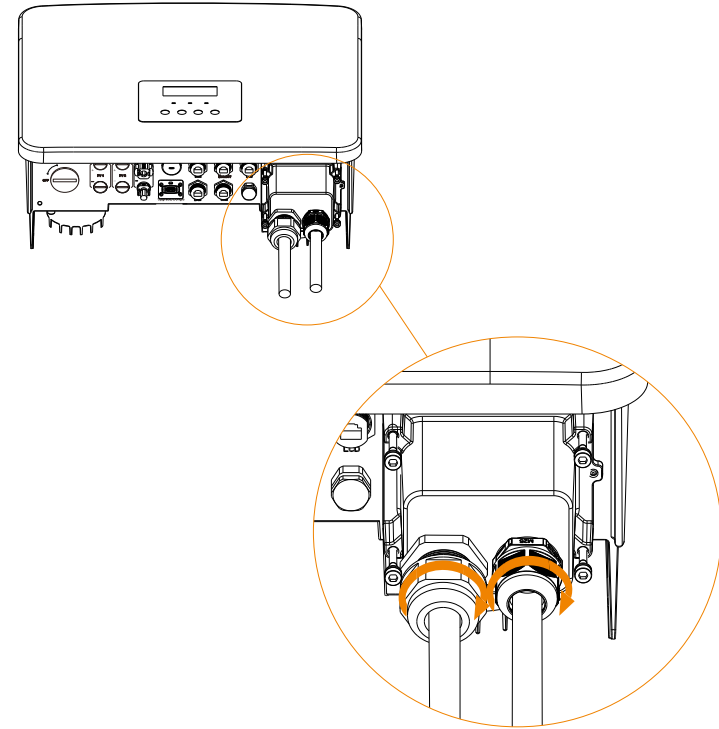

6.3 Battery Connection

➤ Connection requirements

The series inverter charge and discharge system can be equipped with high voltage lithium battery and lead acid battery.

Please note that the maximum voltage of the battery should not exceed 480 V, battery communication should be compatible with the this inverter.

➤ Battery Breaker

Before connecting the battery, a non-polar DC MCB must be installed to ensure safety.

Before maintenance, the inverter need to be safely disconnected.

Model	X1-Fit-3.7-W X1-Fit-3.7-M	X1-Fit-5.0-W X1-Fit-5.0K-W X1-Fit-5.0-M	X1-Fit-6.0-W X1-Fit-6.0-M	X1-Fit-7.5-W X1-Fit-7.5-M
Voltage	Nominal voltage of DC breaker should be larger than maximum voltage of battery.			
Current[A]	32A			

➤ Battery connection diagram

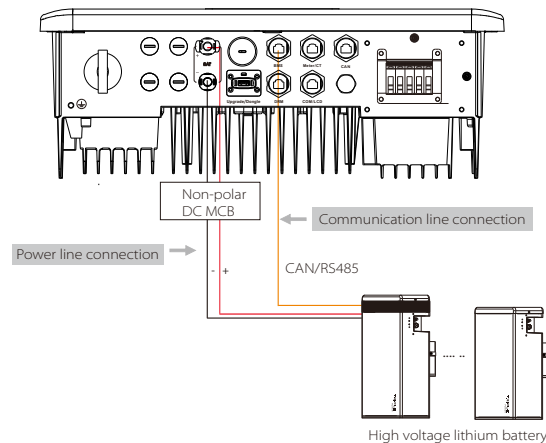

* Whether to add Non-polar DC MCB depends on local safety regulations.

	Battery Control	Battery Modules
Battery & Quantity	T-BAT 5.8 (1 PCS)	HV11550 (0-2 PCS)
Battery & Quantity	MC0600 (1 PCS)	HV10230 (1-4 PCS)
Battery & Quantity	TBMS-MCR0800 (1 PCS)	TP-HR25 (2~8 PCS)
Battery & Quantity	TBMS-MCR0800 (1 PCS)	TP-HR36 (2~8 PCS)
Battery & Quantity	TBMS-MCS0800 (1 PCS)	TP-HS25 (2~8 PCS)
Battery & Quantity	TBMS-MCS0800 (1 PCS)	TP-HS36 (2~8 PCS)

* T58 battery has V1 and V2, V1 and V2 with the same number of inverters, the specific collocation can refer to the relevant part of the battery manual.

➤ Battery connection steps

Battery port connection line of the M series inverter is on the X1-Matebox, just connect it. It is necessary to wire the W series according to the following steps.

Step 1. Prepare 8 mm² battery power line, find the positive battery connector (Part E), negative battery connector (Part D) in the accessory

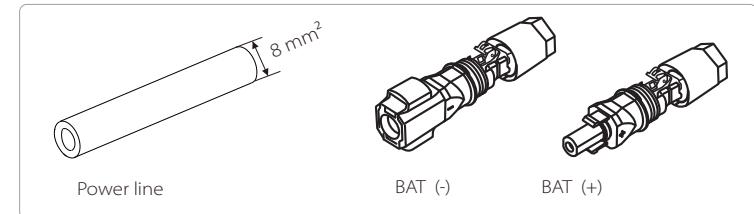

Step 2. Strip the insulation layer (length:15 mm) at one end of the power line.

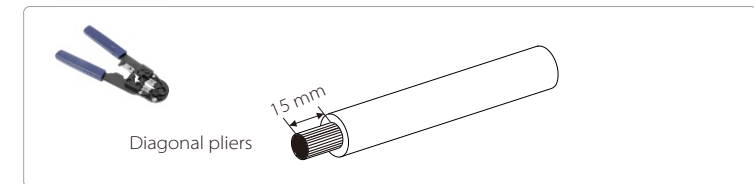

Step 3. Insert the stripped cables into the BAT (-) and BAT (+) respectively.

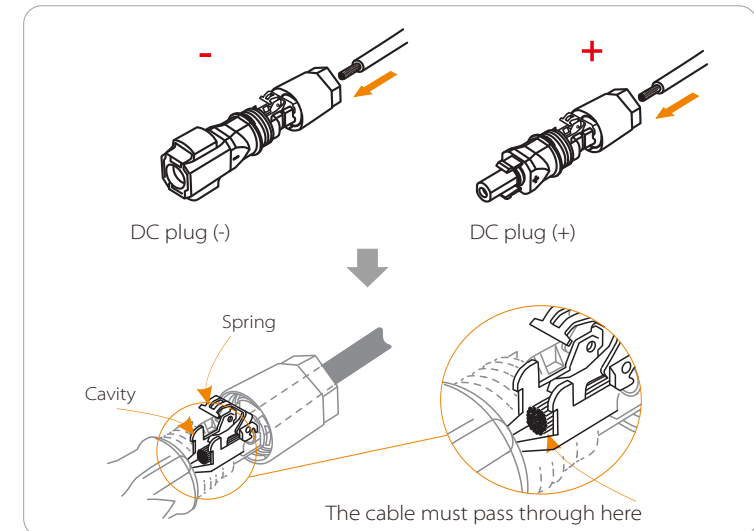

Step 4. Press down on the spring by hand, you can hear a click sound, then push the ends together, and tighten the screw joints.

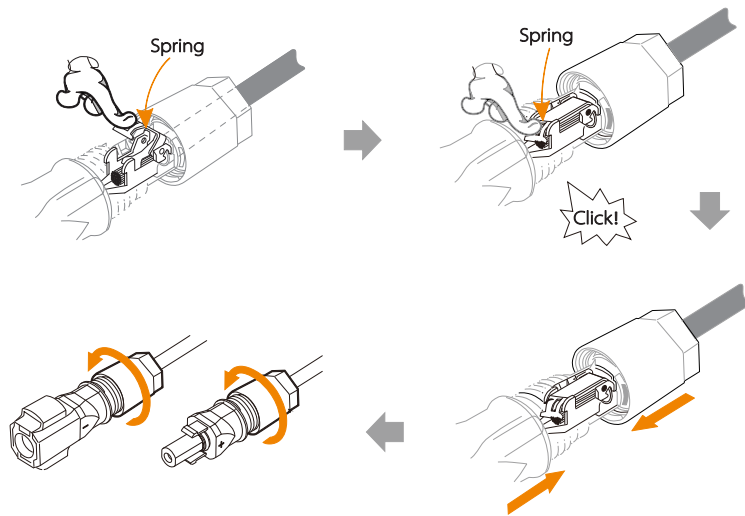

Step 5. Insert the battery power lines into the corresponding BAT port (+), (-) of the inverter.

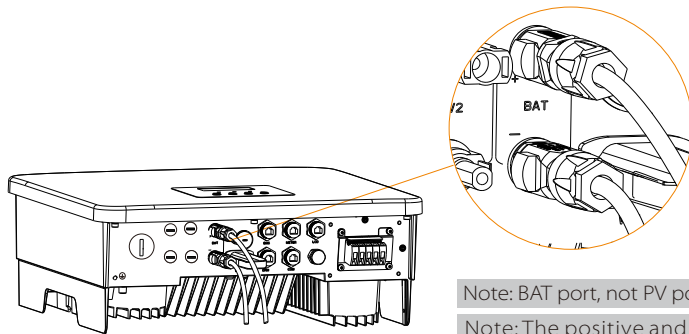

Note: BAT port, not PV port!
 Note: The positive and negative wires of the battery are not allowed to be reversed!

➤ **Communication connection**

BMS port definition

The communication interface between the inverter and the battery uses the waterproof connector with RJ45.

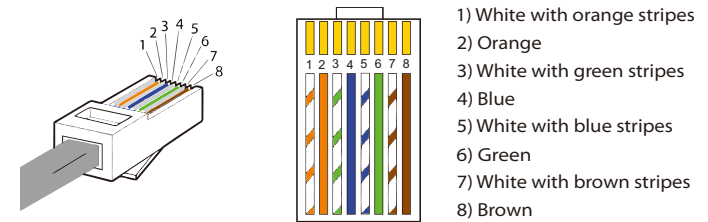

PIN	1	2	3	4	5	6	7	8
Definition	BAT_TEMP	GND	GND	BMS_CANH	BMS_CANL	X	BMS_485A	BMS_485B



Notice!

After the BMS communication between the battery and the inverter is finished, the battery will work normally.

6.4 Communication Connection

6.4.1 Introduction to DRM communication

This inverter can support external control signal response, such as complying with AS4777 regulatory requirements.

➤ **DRM requirements(AS4777 regulatory requirements)**

Mode	Requirement
DRM0	Operation disconnect device
DRM1	Do not consume power
DRM2	Do not consume more than 50% of rated power
DRM3	Do not consume more than 75% of rated power AND Source reactive power if capable
DRM4	Increase power consumption (subject to constraints from other active DRMs)
DRM5	Do not generate power
DRM6	Do not generate more than 50% of rated power
DRM7	Do not generate more than 75% of rated power AND Sink reactive power if capable
DRM8	Increase power generation (subject to constraints from other active DRMs)

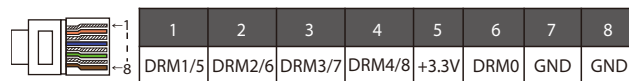

Notice!
 For AS4777 DRM function, currently only PIN6 (DRM0) and PIN1 (DRM1/5) are functional, other PIN functions are under development.

6.4.2 Introduction to meter/CT Communication

The inverter should work with an electric meter or current sensor (CT for short) to monitor household electricity usage. The electricity meter or CT can transmit the relevant electricity data to the inverter or platform, which is convenient for users to read at anytime.

Users can choose to use electric meters or CTs according to demand.

Please Notice that the meter/CT brand required by us must be used.

Notice!
 The meter or CT must be connected to the inverter, otherwise the inverter will shut down and alarm "meter failure" alarm. Smart meters must be authorized by us, third party or other companies. Unauthorized meter may be incompatible with the inverter.
 Our company will not be responsible for the impact caused by the use of other appliances.

➤ **Electric meter connection diagram**

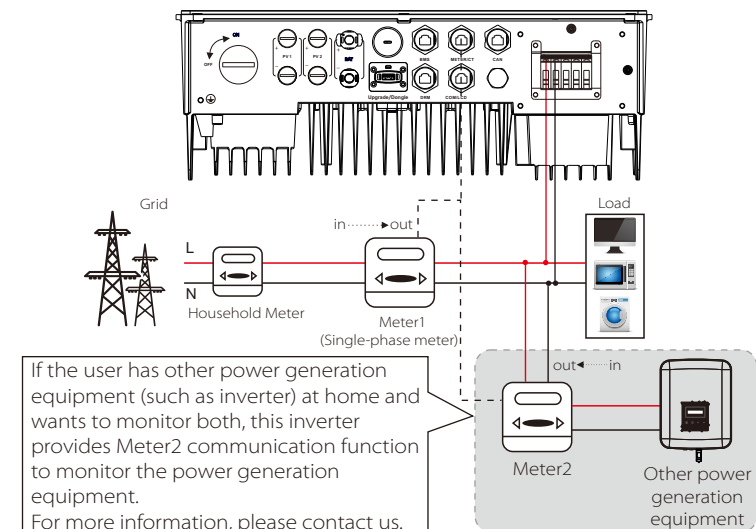

➤ CT Connection

The current sensor measures the current on the live wire between the inverter and the public grid.

• CT connection diagram

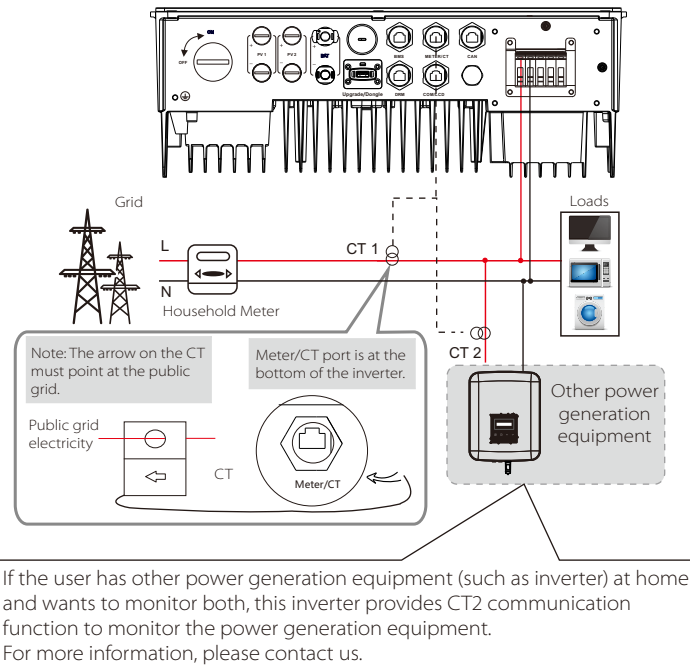

• LCD settings

To select CT, you need to enter Use setting, then enter CT/Meter Setting.

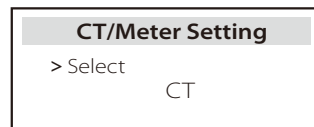

Notice for CT connection:



Notice!

- Do not place the CT on the N wire or ground wire.
- Do not put CT on the N line and L line at the same time.
- Do not place the CT on the side where the arrow points to the inverter.
- Do not place the CT on non-insulated wires.
- The cable length between CT and inverter should not exceed 100 meters.
- After CT is connected, prevent the CT clip from falling off. It is recommended to wrap the CT clip around in circles with insulating tape.



1	2	3	4	5	6	7	8
CT1-1	X	CT2-1	485A	485B	CT2-2	X	CT1-2



Notice!

Only one of the Meter and CT connections can be selected. Meter cable goes to pin terminal 4 and 5; CT cable goes to pin terminal 1 and 8; reserve CT cable goes to pin terminal 3 and 6. If you need this feature,



Notice!

If two meters were to be connected in the system, the communication cables of the meters should be connected in parallel, i.e. 485A & 485A, 485B & 485B.

➤ BMS communication cable

The BMS pin is defined as follows:

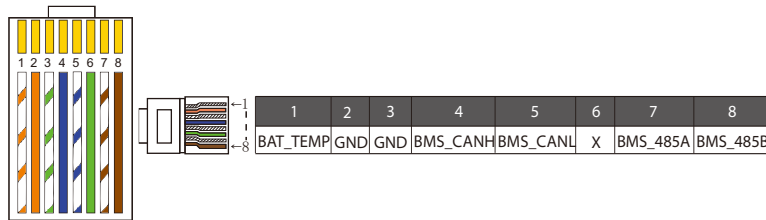

Notice!
 The BMS port on the inverter is the communication port for connecting the battery. The communication port on the lithium battery must be consistent with the definition of pins 4, 5, 7, and 8 above.

➤ DRM communication cable

The DRM pin is defined as follows:

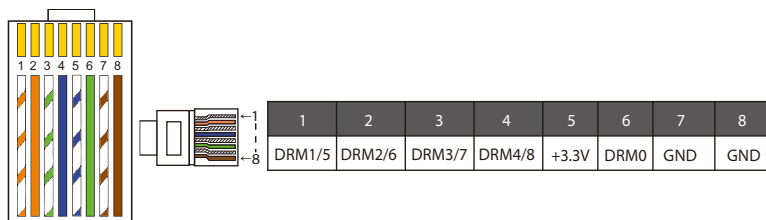

Notice!
 At present, there are only PIN6 (DRM0) and PIN1 (DRM1/5), and other PIN functions are under development.

6.4.3 Parallel Connection

The series inverters provide parallel function, and up to 2 inverters can be connected in a system. In this system, one inverter is set as the "master inverter", and the other inverter is switched to the "slave inverter" state, and the inverters are connected to communicate through the CAN line. The converter "controls the "slave inverter".

➤ System Diagram

System diagram applied to electric meters:

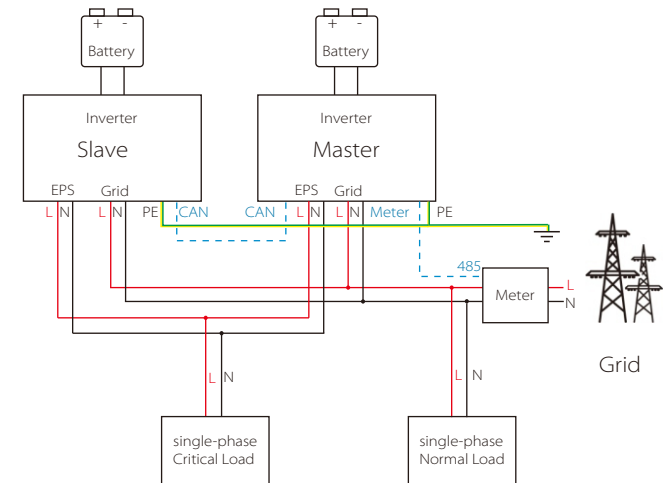

System diagram applied to temperature sensor CT:

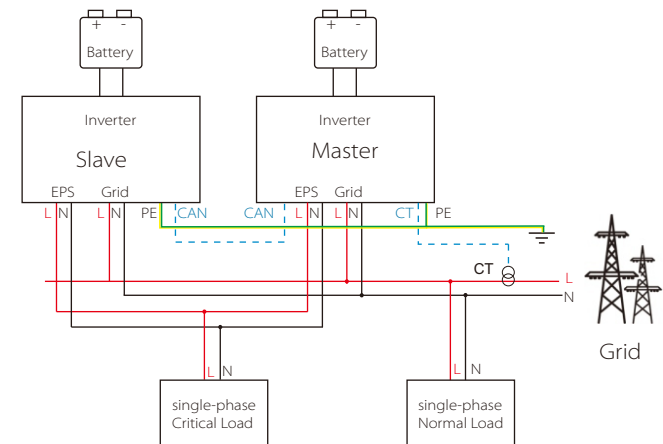

➤ Work Modes in parallel system

There are three work modes in parallel system, and your acknowledge of different inverter's work modes will help you understand parallel system better, therefore please read it carefully before operating.

Free mode	Only when none of the inverters is set to "Master", both inverters are in free mode in the system.
Master mode	When one inverter is set as "Master", this inverter enters master mode. Master mode can be changed to free mode.
Slave mode	Once one inverter is set as "Master", another inverter will enter slave mode automatically. Slave mode cannot be changed from other modes by LCD setting.

➤ Wiring Operation and LCD Setting



Note: Before operation, please make sure that the inverter meets the following three conditions:

1. The software version of all inverters is the same;
2. The power range of all inverter models is the same;
3. The type and quantity of batteries connected to all inverters are the same;

Otherwise, this function cannot be used.

Step1: Connect all inverters' communication together by connecting CAT7 network cables between CAN ports.

- Insert one side of CAT7 cable into the first inverter's CAN port and the other side into the next inverter's CAN port.

- Insert one side of CAT5 cable Meter, and the other side into the Meter port the master inverter.

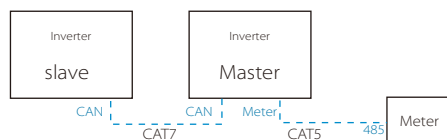

➤ CAN PIN Definition

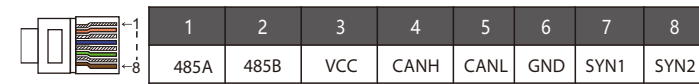

Step 2: Turn on the power of the entire system, find the inverter connected to the meter, enter the setting page of the inverter LCD screen, click on the parallel settings, and select "master control".

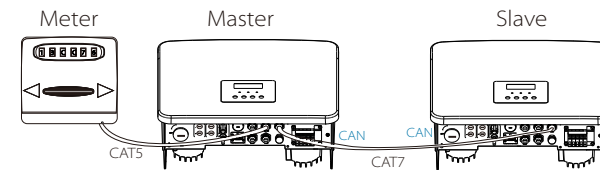

Step 3: Disable "settings - Advanced settings-External ATS" on both master inverter and slave inverter.

➤ How to Remove parallel system

If one inverter wants to exit from this parallel system, please do the steps as below:

- Step1: Disconnect all the network cables on the CAN port.

- Step2: Enter setting page and click parallel setting, and choose "Free".



Note!

- If a slave inverter is set to "Free" mode but not disconnect the network cable, this inverter will return to "slave" mode automatically.
- If a slave inverter is disconnected with other inverter but not be set to "Free" mode, this inverter will stop working and maintain "waiting" status.

➤ LCD display

Main display:

Once inverter enters parallel system, the "today yield" will be replaced by "Inverter Class", and parallel relevant fault has a higher priority than other faults and will be shown firstly on main display.

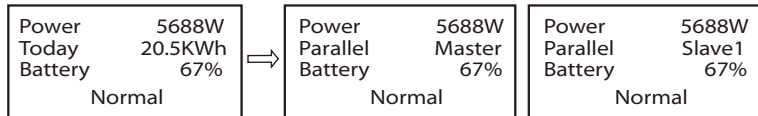

Status display:

User can obtain all the status data from master inverter. System power and individual slave inverter power can be obtain in status display of master inverter.

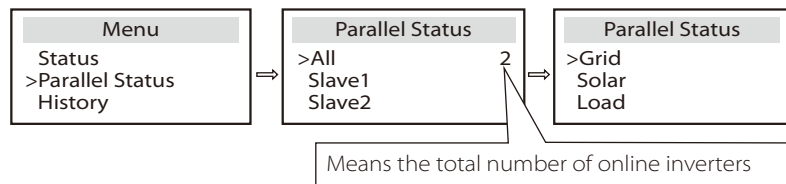

➤ Parallel Control Function

Master inverter has an absolute lead in the parallel system to control slave inverter's energy management and dispatch control. Once master inverter has some error and stop working, slave inverter will be stop simultaneously. But master inverter is independent of slave inverter to work and will not be affected by slave inverter's fault.

Overall system will be running according to master inverter's setting parameters, and most setting parameters of slave inverter will be kept but not be cancelled.

Once slave inverter exit from system and be running as an independent unit, its all setting will be re-excuted.

The rest of this section covers several important parallel control functions, and the next page table shows which LCD options are controlled by master inverter and which can work independently.

Off mode setting:

Off mode can only be set by master inverter (long press ESC button on LCD).

Safety setting:

System safety protection is cancelled by master inverter's safety. Slave inverter protection mechanism will only be triggered by master inverter's instructions.

Self-use setting:

If system is running as self-use mode, please note the Feedin Power Limit set of master inverter is for the overall system and the corresponding set of slave inverter is invalid.

Power Factor setting:

All sets about power factor are all for the overall system and the corresponding sets of slave inverter are invalid.

Remote control setting:

The remote demand instructions received by master inverter will be interpreted as the demand instructions to overall system.

6.4.4 COM Communication

COM communication interface is mainly provided for customization the second step of development use. The inverter supports the control of external equipment or external equipment control through communication. For example, the inverter adjusts the working mode of the heat pump and so on.

➤ Application occasion

COM is a standard communication interface, through which the monitoring data of the inverter can be directly obtained. Also, external communication devices can be connected to carry out the secondary development of the inverter. For specific technical docking, please contact us.

• External communication equipment controls the inverter

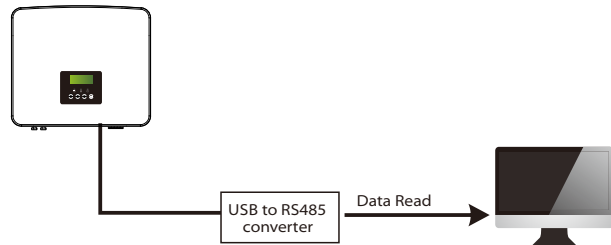

• Inverter communication control external equipment

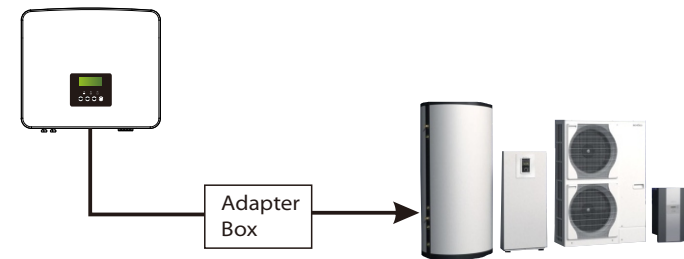

➤ COM PIN Definition

	1	2	3	4	5	6	7	8
	Drycontact_A(in)	Drycontact_B(in)	+12V	485A	485B	GND	Drycontact_A(out)	Drycontact_B(out)

Notice!

 Customers can communicate or control the inverter and external devices through the COM interface. Professional users can use pins 4 and 5 to realize data acquisition and external control functions. The communication protocol is Modbus RTU. For details, please contact us. If the user wants to use the inverter dry contact to control external equipment (such as a heat pump), it can be used with our Adapter Box. For details, please refer to the

6.4.5 Communication Connection Steps

Step 1. Prepare a communication cable, and then find the communication adapter in the accessory bag.

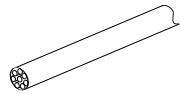

Communication cable

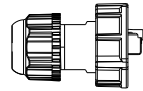

Waterproof connector with RJ45

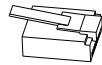

RJ45 terminal

Step 2. Insert the communication cable through the communication adapter, and peel off the outer insulation layer of 15 mm.

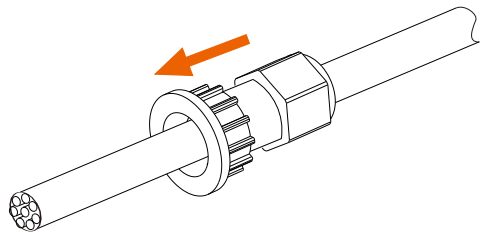

Diagonal pliers

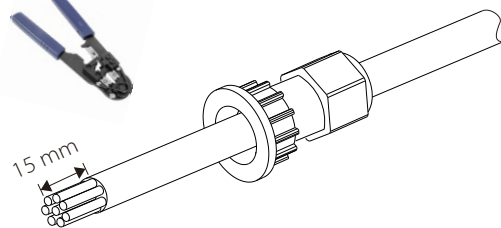

Step 3. Insert the prepared communication cables into the RJ45 terminal in sequence, and then use network cable crimping pliers to press them tightly.

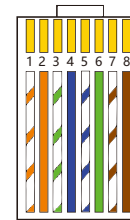

- 1) White with orange stripes
- 2) Orange
- 3) White with green stripes
- 4) Blue
- 5) White with blue stripes
- 6) Green
- 7) White with brown stripes
- 8) Brown



Multifunction terminal crimping tool (RJ45)

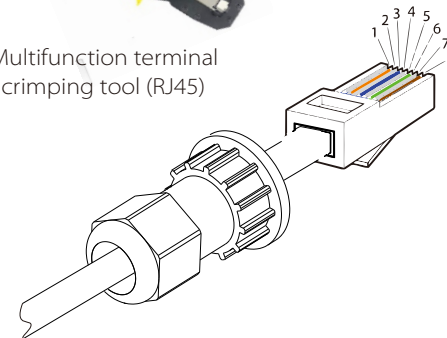

➤ **METER/CT communication cable**

METER/CT pin is defined as follow:

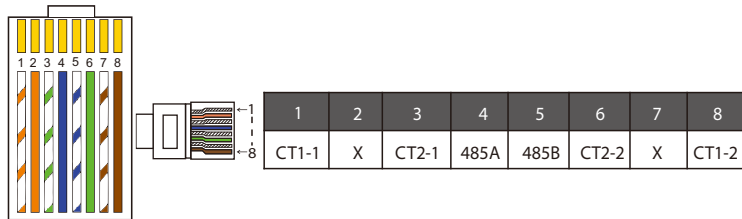

Notice!
 Only one of the Meter and CT connections can be selected.
 Meter cable goes to pin terminal 4 and 5; CT cable goes to pin terminal 1 and 8; CT2 cable goes to pin terminal 3 and 6.

1) Users can customize the length of the CT communication cable. The accessory package provides 1*RJ45 (Part I) and 1*waterproof connector with RJ45 (Part H).
 When the CT cable is completed, connect the A terminal to the "CT/METER" port of the inverter and tighten the waterproof screw, and connect the B terminal to the RJ45 connector (Part M).

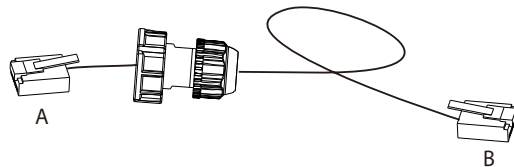

2) One side of the finished cable, Waterproof connector with RJ45 is inserted into the inverter, and one side of the RJ45 terminal is inserted into the CT connection.

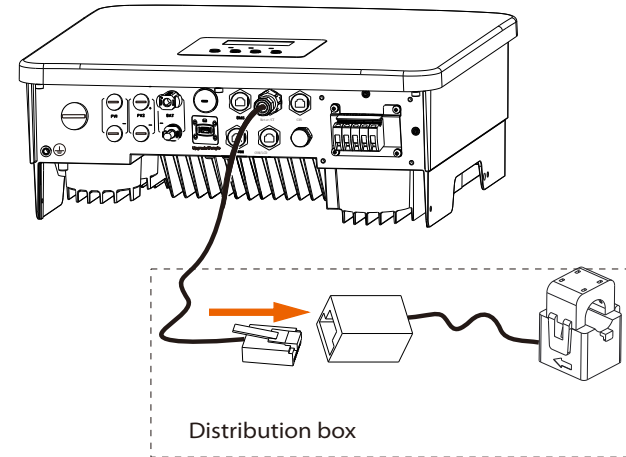

Notice!
 When installing, pay attention to water resistance. All the connected parts of CT must be put into the distribution cabinet.

Step 4. Tighten the completed Meter/CT/BMS communication line and tighten the waterproof plug.

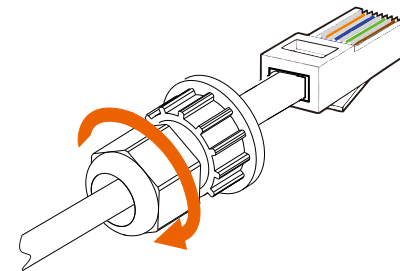

Step 5: Finally, find the corresponding COM, METER, CT, DRM, LCD ports on the inverter and insert the communication cable into the corresponding ports.

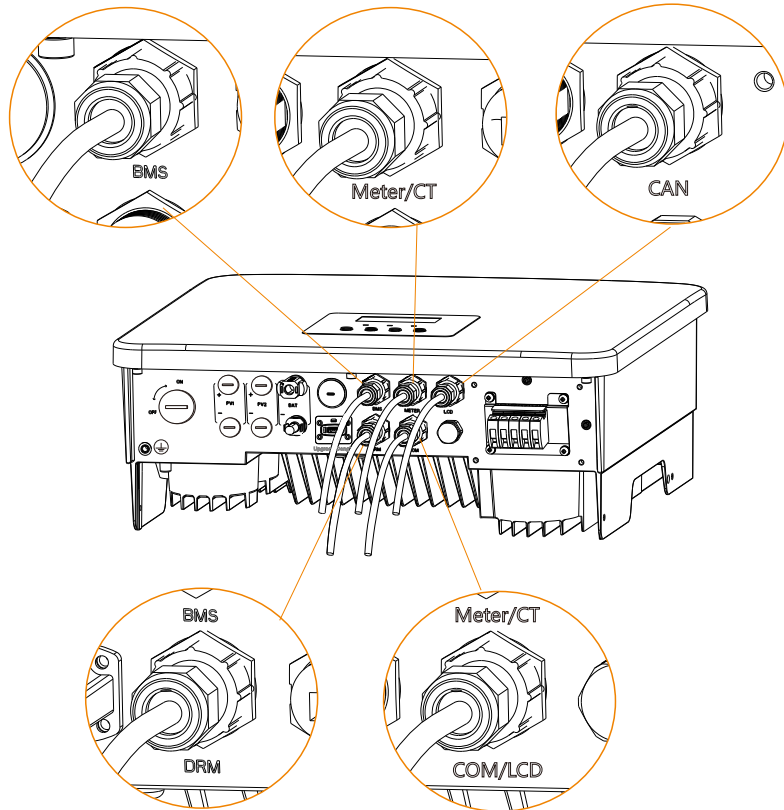

6.5 Grounding Connection (Mandatory)

The user must make two ground connections: one shell grounding, and one equipotential grounding. This prevents electric shock.

The ground wire port of the M series inverter has been connected, and the W series needs to be wired according to the following steps.

➤ Ground connection steps

Step 1. Prepare a one-core cable (4 mm²), and then find the OT terminal (Part F) and M5 inner hexagon bolt (Part G) in the accessories.

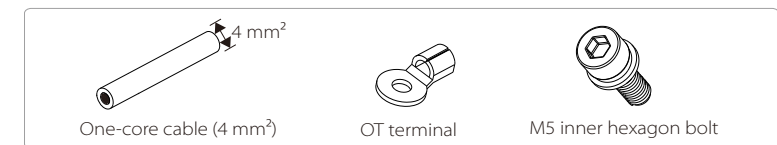

Step 2. Strip the grounding cable insulation (length "L₂"), insert the stripped cable into the OT terminal, and then clamp it.

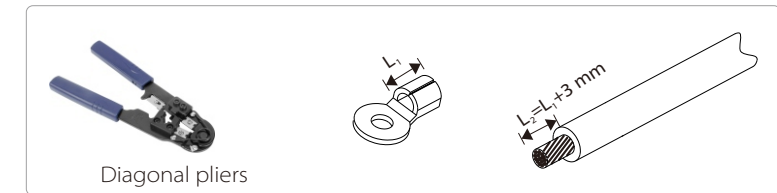

Step 3. Insert the stripped cable into OT terminal and tighten the terminal with a terminal crimping tool.

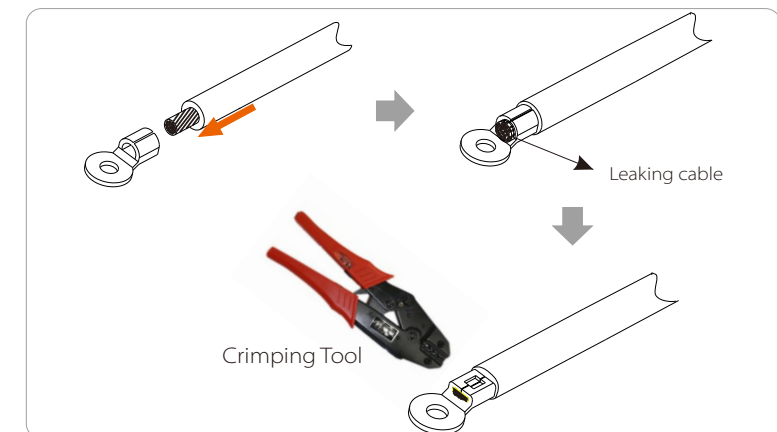

Step 4. Find the ground connection port on the inverter, and screw the ground wire on the inverter with an M5 Hexagon keys.

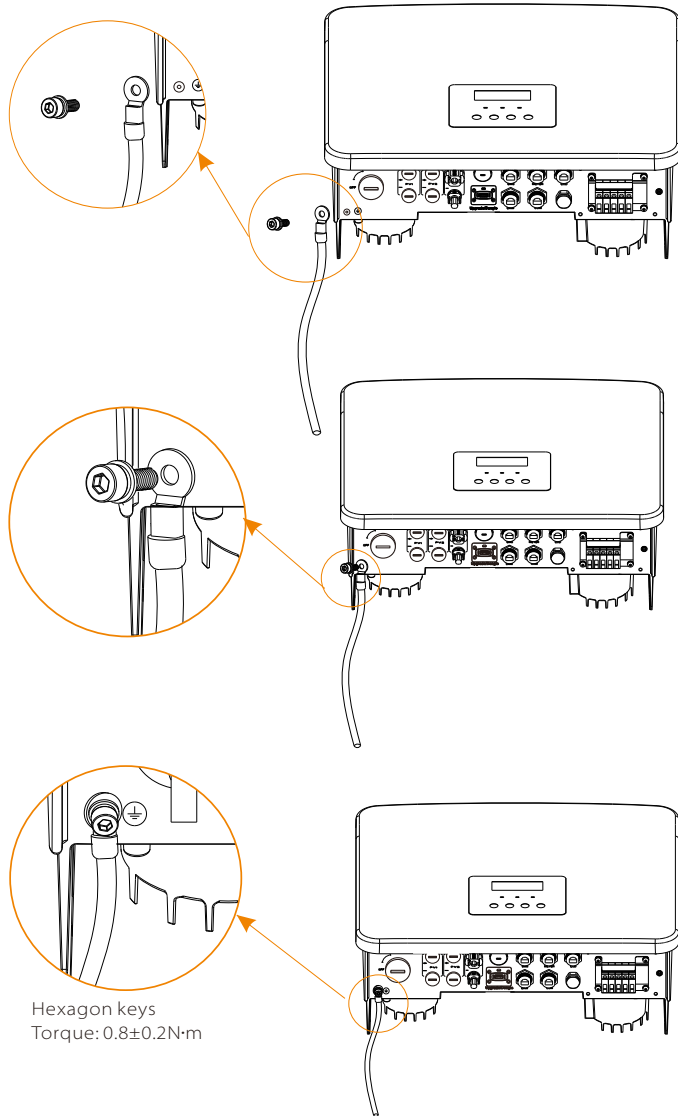

6.6 Monitoring Connection (Accessories)

The inverter provides a DONGLE port, which can transmit data of the inverter to the monitoring website via WiFi + LAN dongle. A WiFi + LAN Dongle can be matched with two kinds of communication modes (WiFi mode or LAN mode).

Notice!
When no device is plugged into Upgrade/Dongle port, ensure the port is covered with a dust cover. Otherwise, it may cause damage to the inverter.

Notice!
WiFi dongle
Harness the power of WiFi with WiFi dongle, connect to a local network within 50m of the installation to enable access to the Cloud monitoring platform.

Notice!
LAN dongle
If WiFi is not suitable for your situation, the LAN dongle enables you to connect to your network via an ethernet cable. Ethernet allows for a much more stable connection with less interference.

➤ Monitoring connection diagram

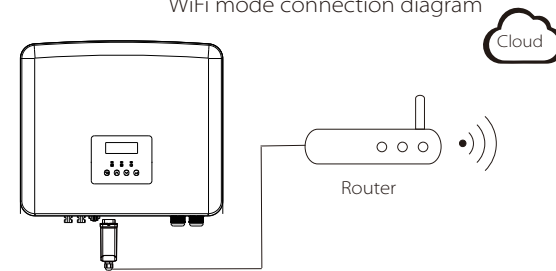
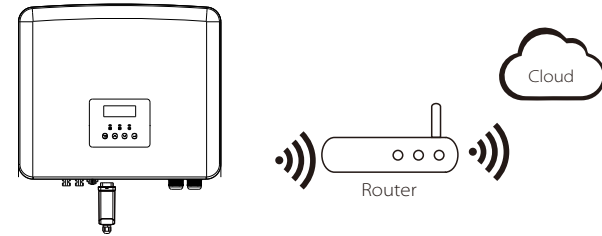

LAN mode connection diagram

➤ **Wireless monitoring accessories connection steps**

WiFi mode

Step 1. Assemble the dongle.

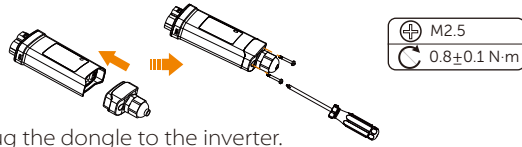

Step 2. Plug the dongle to the inverter.

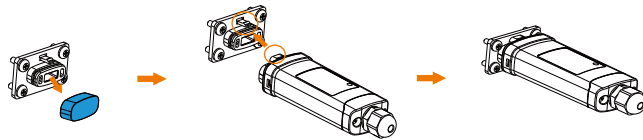

LAN mode

Step 1. Disassemble the waterproof connector into components 1, 2, 3 and 4; Component 1 is not used, keep it in a safe place .

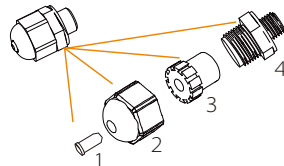

Step 2. Assemble the dongle.

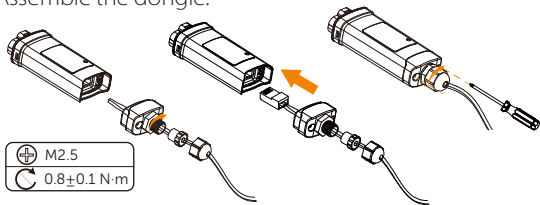

Step 3. Plug the dongle to the inverter.



Caution!

-The buckles must be on the same side. Otherwise, the dongle may be damaged.



Notice!

The longest connection distance between the router and the equipment should be no more than 100 meters, if there is a wall between the router and the equipment, the longest connection distance is 20 meters .



Notice!

Please refer to Pocket WiFi + LAN Installation Guide for instructions on configuring the WiFi. It is important to note that the WiFi configuration should be performed after powering on the inverter.

6.7 Check All Below Steps Before Starting Inverter

➤ After the inverter is checked, then conduct the following steps

- ❶ Make sure that the inverter is fixed on the wall.
- ❷ Ensure that all ground wires are grounded.
- ❸ Confirm that all DC lines and AC lines are connected.
- ❹ Make sure the CT is connected.
- ❺ Make sure the battery is well connected.
- ❻ Turn on the Load breaker and EPS(Off-grid) breaker.
- ❼ Turn on the battery breaker.
- ❽ Turn on the DC switch.

Long press the "Enter" key for 5 seconds to exit the Off mode.
(The mode is factory defaulted as Off Mode)

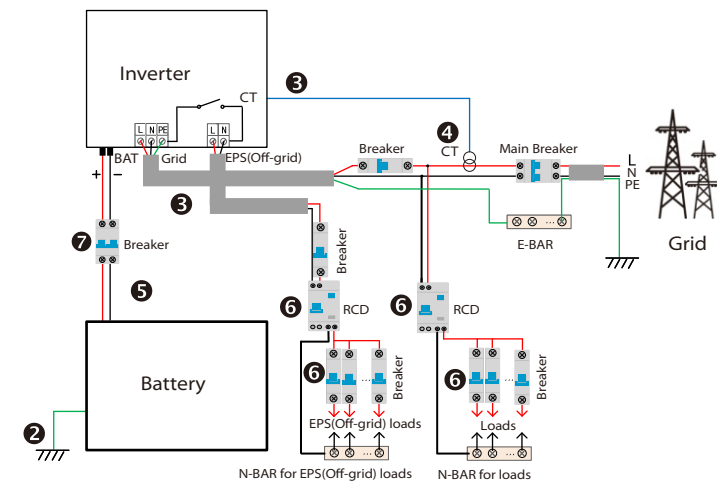

6.8 Inverter Operation

➤ Before operation, check the inverter according to the following steps

- Check that the inverter is well fixed on the wall.
- Ensure that all ground wires are well tightened.
- Ensure that all AC circuit breakers are disconnected.
- Ensure that all ground wires are well tightened.
- The AC output terminal is correctly connected to the mains.

➤ Start the inverter

- Steps to start the inverter
 - Turn on the AC switch between the inverter and the power grid.
- Check the status of the LED and LCD screen, the LED is green, and the LCD screen displays the main interface.
- If the LED is not green, please check the following:
 - All connections are correct.
 - All external disconnect switches are closed.

The following are 3 different states of inverter operation, which means that the inverter starts successfully.

Waiting: When the DC output voltage of the photovoltaic panel is higher than 70 V (lowest starting voltage) and lower than 90 V (lowest working voltage), the inverter waits for checking.

Checking: The inverter will automatically detect the DC input. When the DC input voltage of the photovoltaic panel is higher than 90 V and the photovoltaic panel has enough energy to start the inverter, the inverter will enter the checking state.

Normal: When the inverter is working normally, the green light is always on. At the same time, the power is fed back to the grid, and the LCD displays the output power.

If it is the first time to boot, please follow the prompts to enter the setting interface.



Warning!

The input terminal of the inverter can be opened only when all the installation work of the inverter has been completed. All electrical connections must be performed by professionals in accordance with local regulations.



Notice!

If it is the first time to operate the inverter, the system will automatically display setup guide. Please follow the setup guide to complete the basic inverter settings.

7 Firmware Upgrading

➤ Upgrade Notices

Please read the following precautions before upgrading.



Warning!

-In order to upgrade the firmware smoothly, if the DSP and ARM firmware need to be upgraded, please note that ARM firmware must be upgraded first, then DSP firmware!
-Please make sure that the category format is correct, do not modify the firmware file name, otherwise, the inverter may not work!



Warning!

-For this inverter, please ensure that the battery SOC is greater than 20% or the battery input voltage is greater than 90 V. Otherwise, it may cause serious failure during the upgrade process!



Caution!

-If the ARM firmware upgrade fails or stops, please do not unplug the U disk power off the inverter and restart it. Then repeat the upgrade steps.



Caution!

-If the DSP firmware upgrade fails or stops, please check whether the power is off. If it is normal, plug in the U disk again and repeat the upgrade.

➤ Upgrade preparation

1) Please check the inverter version and prepare a U disk (USB 2.0/3.0) and personal computer before upgrading.



Caution!

-Please make sure that the size of the U disk is smaller than 32G, and the format is fat 16 or fat 32.

2) Please contact our service support to obtain the firmware, and store the firmware in the U disk according to the following path.

Update:

For ARM file:update\ARM\618.xxxxx.00_HYB_1P_ARM_Vx.xx_xxxxxxxx.usb*;

For DSP file:update\DSP\618.xxxxx.00_HYB_1P_DSP_Vx.xx_xxxxxxxx.usb*;

Note: Vx.xx is version number, xxxxxxxx is file completion date.

➤ **Upgrade steps**

Step 1. Please save the "Update" firmware in your U disk first, and press the "Enter" button on the inverter screen for 5 seconds to enter the OFF mode.

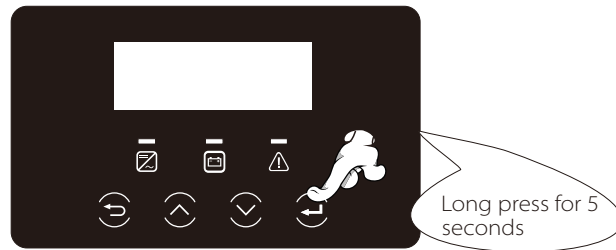

Step 2. Find the "Upgrade" port of the inverter, unplug the monitoring module (WiFi Dongle/LAN Dongle/4G Dongle) by hand, and insert the USB flash drive.

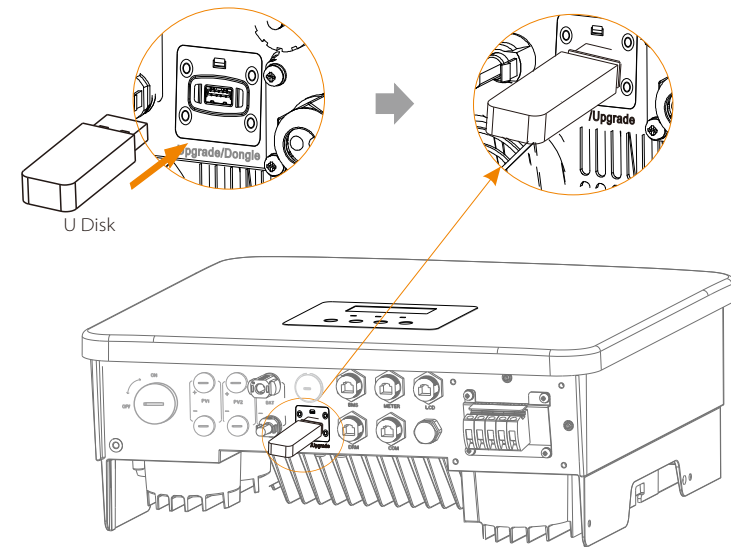
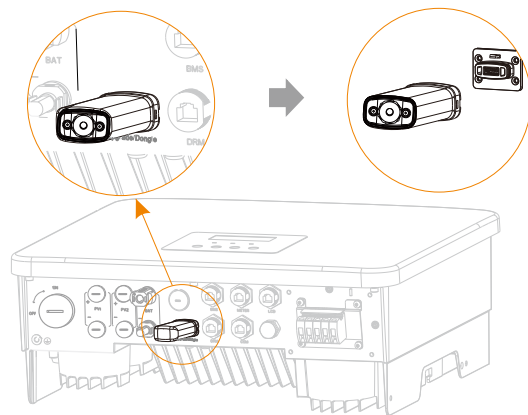

Step 3. LCD operation, enter the upgrade interface "update", as shown below(a): Please press the up and down keys to select ARM, then press down to set "OK", press the enter key to enter the software version interface;

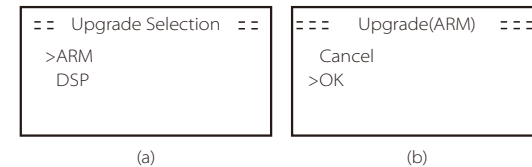

Step 4. Please confirm the new firmware version again and select the firmware to upgrade. The upgrade takes about 20 seconds. (d) When it is completed, the LCD screen returns to the "Update" page.

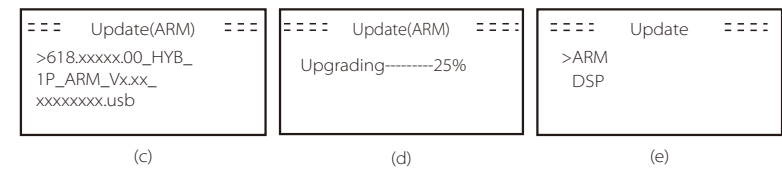

Step 5. For DSP: Please wait for 10 seconds. When "Update" page shown as below, press down to select "DSP" and then press Enter. Please confirm the firmware version again and press Enter to upgrade. The upgrade takes about 2 minutes.

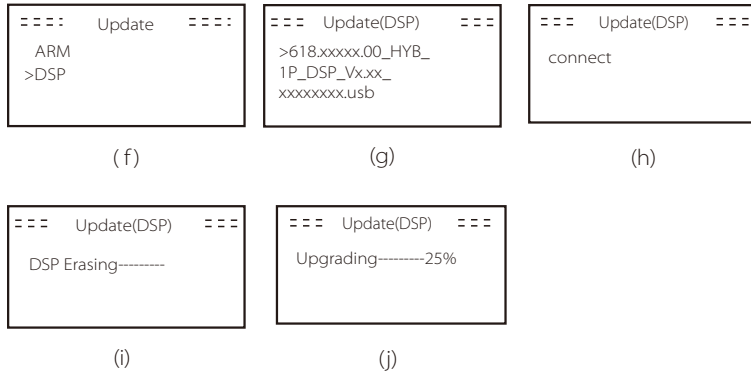

Step 6. After the upgrade is completed, the LCD screen displays "Upgrade Successful".

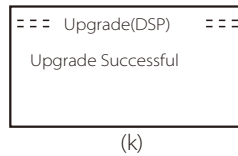

Step 7. Plug off the U disk, press "Esc" to return to the main interface, and long press the enter key to exit the mode.

Caution!
 -Please strictly follow each step from step 1-6, don't miss it.
 -Please confirm the ARM/DSP firmware version on the USB flash drive.

Tip: If the display screen is stuck on "X1-Fit G4" after the upgrade, please restart, and the inverter will return to normal. If not, please contact us for help.

8 Setting

8.1 Control Panel

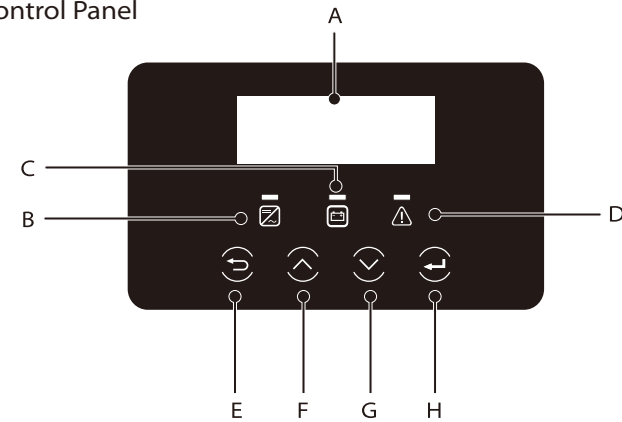

Object	Name	Description
A	LCD Screen	Display inverter information on the LCD display.
B	LED Indicator light	Blue light: The inverter is in normal state or EPS(Off-grid) mode. Blue flashing: The inverter is in the waiting, checking state or the system switch is off. Off: The inverter is in a fault state.
C		Green: The battery communication is normal and working normally. Green flashing: The battery communication is normal and in an idle state. Off: The battery does not communicate with the inverter.
D		Red light on: The inverter is in a fault state. Off: The inverter has no error.
E	Key Function	ESC button: Return from the current interface or function.
F		Up button: Move the cursor to the upper part or increase the value.
G		Down button: Move the cursor down or decrease the value.
H		Enter button: Confirm selection.

Note: When the inverter is in an idle state, you can reset the work mode, the Min SOC and the charging periods through the inverter LCD or the SolaX APP to charge the battery to the Min SOC in the charging periods and then awaken the inverter. Please make sure that the actual battery SOC - the modified Min SOC ≥ 2% under a specific work mode, so that other modifications are effective. When the current system time is within the new charging periods you reset, the battery begins charging.

8.2 Menu Structure

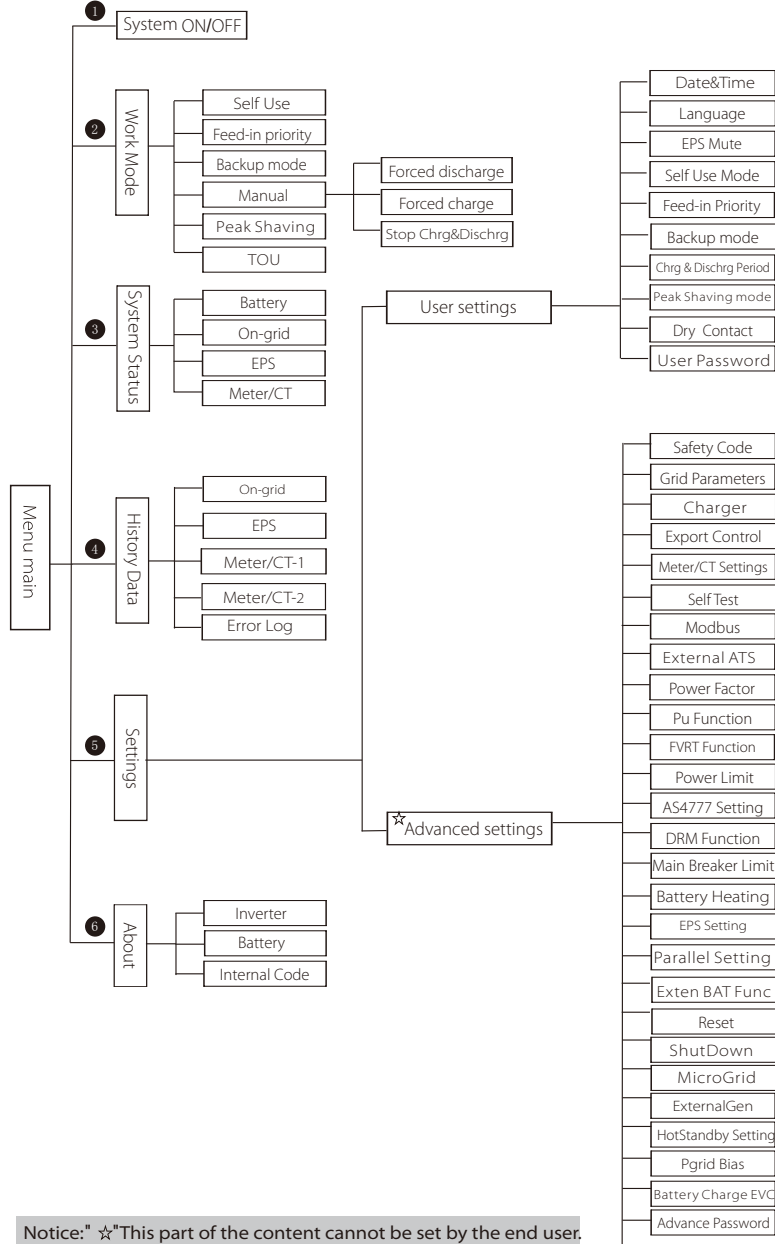

Notice: ☆ This part of the content cannot be set by the end user. Please contact the installer or us if necessary.

8.3 LCD Operation

The main interface is the default interface, the inverter will automatically return to this interface when the system started up successfully or not operated for a period of time.

The information of the interface is as below. "Power" means the instant output power; "Today" means the power generated within the day. "Battery" means the left capacity of battery energy.

Power	0W
Today	0.0KWh
Battery	80%
Normal	

➤ Menu interface

The menu interface is another interface for users to change settings or obtain information.

-When the LCD displays the main interface, click "OK" to enter this interface.

-The user can select up and down the menu, and press the "OK" key to

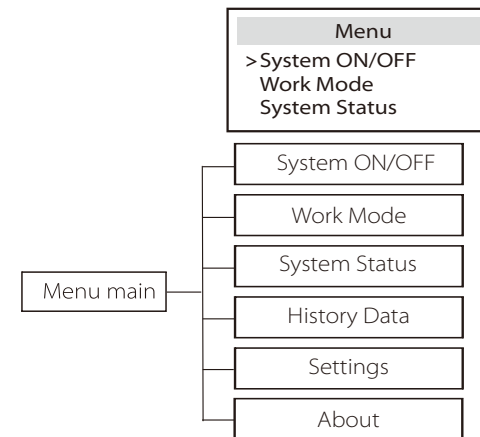

➤ System ON/OFF

"ON" indicates that the inverter is in working state, which is generally the default state.

"OFF" means that the inverter stops running and only the LCD screen is turned on.

System ON/OFF
Switch
>OFF<

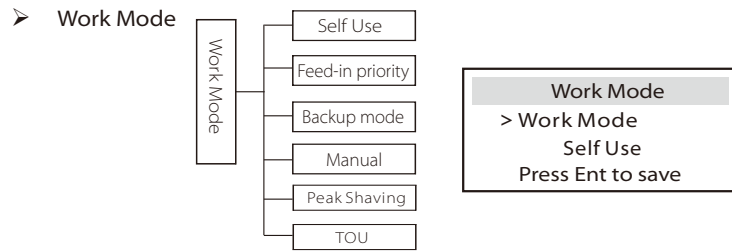

When **X1-Fit G4 series inverter** matches with **grid-tied inverter**, the following work modes are available.

For **on-grid** status, there are five work modes: Self Use, Feed-in Priority, Backup, Manual and Peak shaving mode.

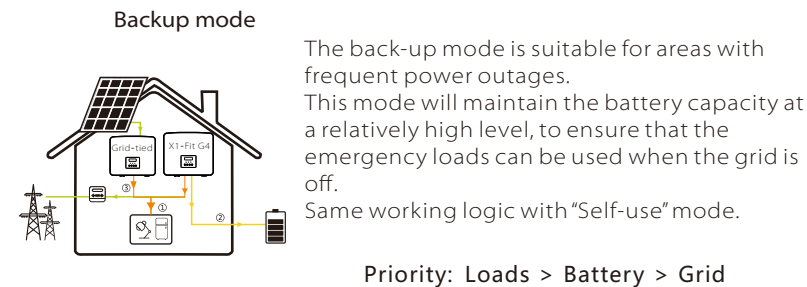
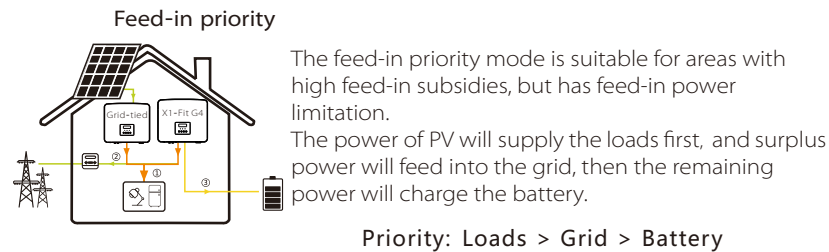
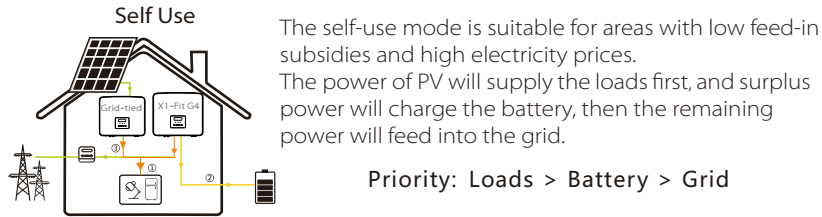

* For the above three work modes, when the power of PV is insufficient to supply the loads, the battery will supply the loads. If the battery is insufficient, then the grid will supply the loads.

Manual

This work mode is for the after-sales team to do after-sales maintenance.

Manual mode (manual mode), there are three options to choose from: forced charging, forced discharge, stop charging and discharging (grid-connected 0 power).

Work Mode	Work Mode	Work Mode
>Manual Forced Discharge	>Manual Forced Charge	>Manual Stop Chrg&Dischrg

For **off-grid** status, there is only one work mode: EPS (Off-grid).

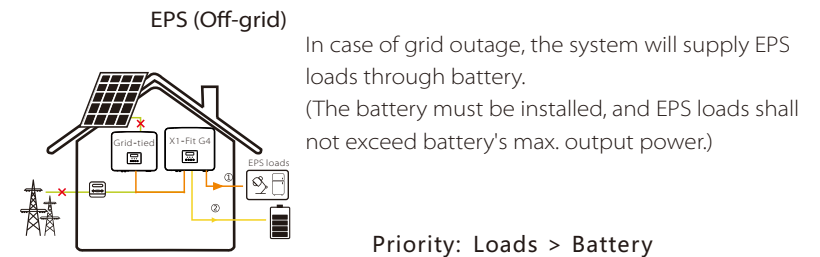

Note:

The battery will stop discharging when SOC=min SOC. But due to battery self consumption, sometimes SOC may < min SOC.

For on-grid status, if the battery SOC ≤ (min SOC-5%), the inverter will take utility energy to charge battery SOC back to (min SOC+1%).

For off-grid status, if the battery SOC ≤ min SOC, the inverter will be unable to enter EPS mode (the battery will be unable to discharge) unless SOC is back to 31%.

Peak shaving mode

Peak Shaving mode is set for leveling out peaks in electricity use. System is controlled to charge up during off-peak hours and discharged during peak hours.

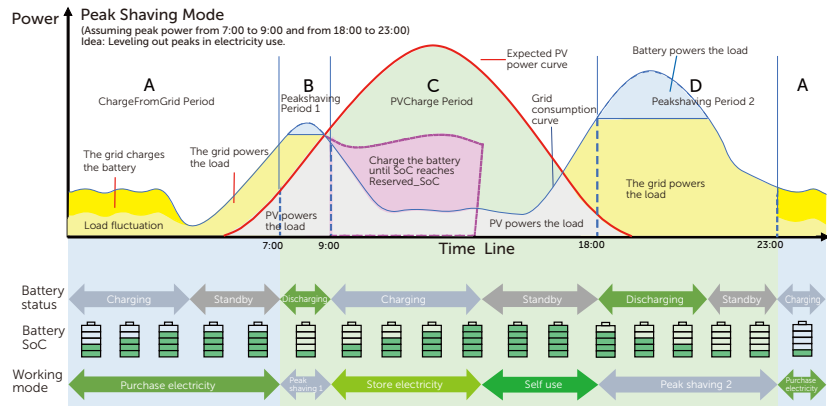

Time period	Battery SOC	Load and peaklimits conditions	Inverter working status
Period A	X	X	Battery charging period during which discharging is not allowed and the PV will charge the battery first for peak shaving.
Period B and D	X	Load < Peaklimits	The PV will charge the battery first. When the battery is fully charged, the PV will supply power for loads, and the surplus power will feed into the grid.
	X	Load > Peaklimits	The PV and battery will discharge energy for loads and thus reduce the amount of energy purchased from the grid.
Period C	X	X	The battery does not discharge. The PV will charge the battery to the "Reserved SOC" first and then supply power for loads, with the surplus power feeding into the grid. Charging the battery first in these periods is storing energy for the peak shaving.

Note:
 PeakLimits (W): The load consumption from grid side.
 Reserved SOC (%): Refers to the lower limit of SoC required for later peak shaving period. The default value is 50%. The adjustment range is 10~100%.
 X: Not applicable.

TOU

TOU can only be set in SolaX Cloud App. Aftering setting the TOU in the App, the selected TOU mode will be displayed in TOU interface on the LCD.

Min SoC: The minimum SoC of the system.

Min Soc: Default: 10%

Work Mode

Work Mode:
TOU
Press Ent to save

TOU

Min Soc:
10%

Self-use: Same working logic with "Self-use Mode", but it is not limited by the charging and discharging time slots. The priority of PV: Loads > Battery > Grid.

Min Soc: Default: 10% Range: 10~100%

TOU

Current Mode:
Self-use

Self-use

Min Soc:
10%

Battery off: The battery neither charges nor discharges. The power of PV will supply to loads or the grid. Only when the battery SOC is lower than the system (TOU) Min SOC, the battery can be charged.

TOU

Current Mode:
Battery off

Peak shaving: The working logic is that when the power consumption from the grid exceeds the set PeakLimit value, the battery is allowed to discharge power. The excess power beyond the limit is provided by the combination of photovoltaic and battery to ensure that the maximum power purchased from the grid does not exceed the set limit.

Peaklimits: Default: 1000W

TOU

Current Mode:
Peak shaving

Peak shaving

Peaklimits:
1000W

Charging: The power of PV will charge the battery as much as possible to the set SOC of Charge BAT to (%). You can set whether to Charge from grid. The default value of Charge BAT to (%) is 100%. When the battery reaches the set SOC, the surplus power will perform "Self-use Mode" or supply to the grid (based on the system setup), at this point, Charge from grid is not allowed.
 Charge from grid: Default: Disable
 Charge BAT to: Default: 50% Range: 10~100%

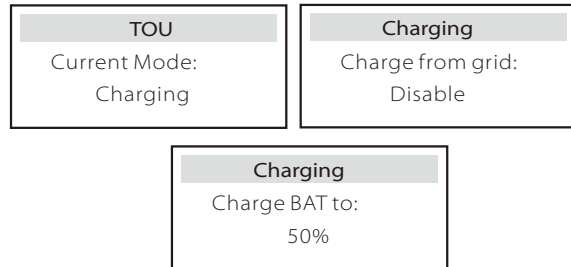

Discharging: If allowed by the battery, the system outputs a specified power from the grid based on the set output percentage, controlling the power at the AC port. You need to set the RatePower (%) through Web or App when choosing Discharging mode. When the battery Discharge to (%) reaches the set SOC, the inverter performs "Self-use Mode".
 Rate of AC Power: Default: 100% Range: 10~100%
 Discharge to: Default: 10% Range: 10~100%

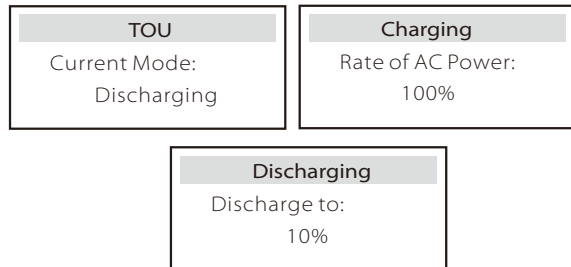

➤ System Status

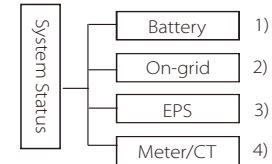

System status contains four contents: Battery/On-grid (energy feed into or buy from the grid) , EPS and so on.

Press up and down to select, press "Enter" to confirm the selection, and press "ESC" to return to the menu.

1) Battery

This status shows the battery condition of the system. Including battery voltage and battery current, battery power, battery capacity, battery temperature and BMS connection status. The meaning of the sign of battery current and power: "+" means charging; "-" means discharging.

Battery	
U	400.0V
I	-1.0A
P	-400W

2) On-grid

Here you can see the voltage, current, frequency, and power of the grid.

On-grid	
U	0.0V
I	0.0A
P	0.0W

3) EPS

Here you can see the voltage, current, frequency and power of the inverter when it is disconnected from the grid.

EPS	
U	0.0V
I	0.0A
P	0VA

4) Meter/CT

Here you can see the data showing the meter or the CT.

Meter/CT	
>Meter/CT-1	
Meter/CT-2	

Meter/CT	
>Meter/CT-1	4000w

Meter/CT	
>Meter/CT-2	4000w

> History Data

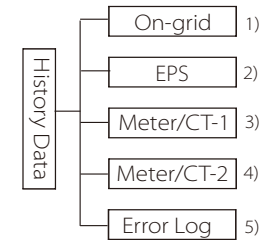

The history data contains five pieces of information: on-grid power of the inverter, EPS power generation, power of the meter/CT and error logs.

Press up and down to select, press Enter to confirm selection, and press ESC to return to the menu.

1) On-grid

Here is a record of the power capacity of the inverter connected to the grid today and the total.

<table border="1"> <thead> <tr> <th colspan="2">On-grid</th> </tr> </thead> <tbody> <tr> <td>Output Today</td> <td>0.0 kWh</td> </tr> </tbody> </table>	On-grid		Output Today	0.0 kWh	<table border="1"> <thead> <tr> <th colspan="2">On-grid</th> </tr> </thead> <tbody> <tr> <td>Output Total</td> <td>0.0 kWh</td> </tr> </tbody> </table>	On-grid		Output Total	0.0 kWh
On-grid									
Output Today	0.0 kWh								
On-grid									
Output Total	0.0 kWh								
<table border="1"> <thead> <tr> <th colspan="2">On-grid</th> </tr> </thead> <tbody> <tr> <td>Input Today</td> <td>0.0 kWh</td> </tr> </tbody> </table>	On-grid		Input Today	0.0 kWh	<table border="1"> <thead> <tr> <th colspan="2">On-grid</th> </tr> </thead> <tbody> <tr> <td>Input Total</td> <td>0.0 kWh</td> </tr> </tbody> </table>	On-grid		Input Total	0.0 kWh
On-grid									
Input Today	0.0 kWh								
On-grid									
Input Total	0.0 kWh								

2) EPS

Here you can see the EPS output of the inverter today and the total output.

<table border="1"> <thead> <tr> <th colspan="2">EPS</th> </tr> </thead> <tbody> <tr> <td>Today:</td> <td>0.0 kWh</td> </tr> </tbody> </table>	EPS		Today:	0.0 kWh	<table border="1"> <thead> <tr> <th colspan="2">EPS</th> </tr> </thead> <tbody> <tr> <td>Total:</td> <td>0.0 kWh</td> </tr> </tbody> </table>	EPS		Total:	0.0 kWh
EPS									
Today:	0.0 kWh								
EPS									
Total:	0.0 kWh								

3) Meter /CT-1

Here you can see the inverter electricity sold, total electricity sold, electricity bought from the grid and total electricity bought on that day.

Meter/CT-1	Meter/CT-1
>FeedIn Today: 00.0KWh	>FeedIn Total: 00.0KWh
>Consume Today: 00.0KWh	>Consume Total: 00.0KWh

4) Meter /CT-2

Here you can see the total power output of the inverter for the day.

Meter/CT-2	Meter/CT-2
>Output Today: 00.0KWh	>Output Total: 00.0KWh

5) Error Log

Here you can see the most recent six error messages.

Error log
>No error

➤ User Settings

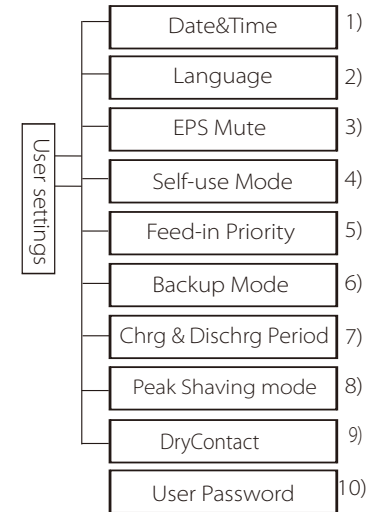

Here you can set the inverter time, language, working mode, charging and discharging time period and user password.

User Setting
Date&Time Language EPS Mute

1) Date&Time

This interface is for users to set the system date and time.

Date&time
>2019 - 11 - 15 10 : 19

2) Language

This inverter provides multiple languages for customers to choose.

Language
> Select: English

3) EPS Mute

Here you can choose whether the buzzer is turned on when the inverter is running in EPS mode. Select Yes, the buzzer mutes, select NO, EPS mode, the buzzer will sound once every 4s when the battery is fully charged, the closer the battery is to the empty state, the higher

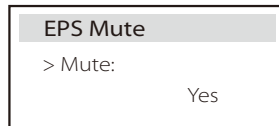

4) Self-use mode

In this mode, you can set the power reserve percentage of the minimum battery state, set whether the power can be taken from the mains side to charge the battery, and set the amount of power to charge the battery. For example: set the reserved minimum SOC of the battery capacity to "10%", which means that when the battery has been discharged to 10% of the battery capacity, the battery is not allowed to continue to discharge; When Charge from grid is set to "Enable", the utility power is allowed to charge the battery; when set to "Disable", the utility power is not allowed to charge the battery; Charge battery to is set to 90%, indicating that the mains is allowed to charge the battery at 90%.

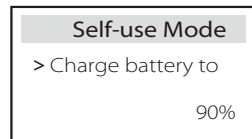
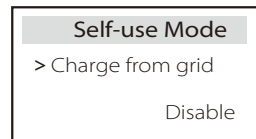
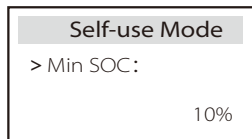

5) Feed-in Priority

In this mode, you can set the power reserve percentage of the minimum battery state, set whether the power can be taken from the mains side to charge the battery, and set the amount of power to charge the battery. For example: set the reserved minimum SOC of the battery capacity to "10%", which means that when the battery has been discharged to 10% of the battery capacity, the battery is not allowed to continue to discharge;

Charge battery to is set to 90%, indicating that the mains is allowed to charge the battery at 90%.

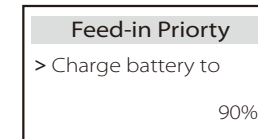
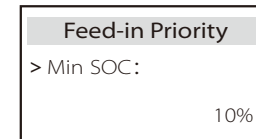

6) Backup mode

In this mode, you can set the power reserve percentage of the minimum battery state, set whether the power can be taken from the mains side to charge the battery, and set the amount of power to charge the battery. For example: set the reserved minimum SOC of the battery capacity to "30%", which means that when the battery has been discharged to 30% of the battery capacity, the battery is not allowed to continue to discharge;

Charge battery to is set to 90%, indicating that the mains is allowed to charge the battery at 90%.

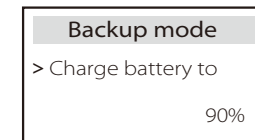
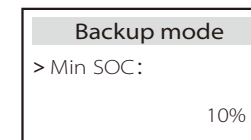

7) Charge and discharge period

Here you can set the charge and discharge time period. If two charging and discharging periods are needed, turn on the charging and discharging period 2 and set the period.

Chrg&DischrgPeriod > Forced Chrg Period Start Time 00:00	Chrg&DischrgPeriod > Forced Chrg Period End Time 00:00	Chrg&DischrgPeriod > Allowed Disc Period Start Time 00:00
Chrg&DischrgPeriod > Allowed Disc Period End Time 00:00	Chrg&DischrgPeriod2 > Function Control Enable	Chrg&DischrgPeriod2 > Forced Chrg Period Start Time 00:00
Chrg&DischrgPeriod2 > Forced Chrg Period End Time 00:00	Chrg&DischrgPeriod2 > Allowed Disc Period Start Time 00:00	Chrg&DischrgPeriod2 > Allowed Disc Period End Time 00:00

8) Peak Shaving mode

This setting is for enabling peak shaving mode. "DisChgPeriod1" and "DisChgPeriod2" are two discharging periods you can set. Set "ShavingStartTime1" (default value: 7:00) and "ShavingEndTime1" (default value: 15:00) under "DisChgPeriod1", and "ShavingStartTime2" (default value: 19:00) and "ShavingEndTime2" (default value: 23:00) under "DisChgPeriod2" to define the peak hours of electricity. Set "PeakLimits1/2" to limit the power that loads get from the grid. Once the power of loads exceeds "peak limits" during the peak hours, the PV and battery will discharge energy for loads and thus reduce the amount of energy purchased from the grid. In non-peak hours, discharging of the battery is not allowed. If you want to get electricity from the grid, set "ChargeFromGrid" to "Enable". "Disable" is the default setting. When you select "Enable" and the actual battery SOC is less than "MAX_SOC" (settable), the battery can be charged from the grid at no more than "ChargePowerLimits" (settable) power. Range of "ChargePowerLimits": 0 W~rated power (W) The range of "MAX_SOC" is 10%~100%; the default value is 50%. Range of "Reserved_SOC" is 10%~100%; the default value is 50%. "Reserved_SOC" is the battery capacity saved for the next peak shaving in the non-peak shaving period.

User Setting > Peak shaving mode	Peak shaving mode >DisChgPeriod1 DisChgPeriod2 ChargeFromGrid	DisChgPeriod1 ShavingStartTime 07:00
--	---	---

DisChgPeriod1 ShavingEndTime 15:00	DisChgPeriod1 ShavingLimits1 0W	Peak shaving mode DisChgPeriod1 >DisChgPeriod2 ChargeFromGrid
DisChgPeriod2 ShavingStartTime 19:00	DisChgPeriod2 ShavingEndTime 23:00	DisChgPeriod2 ShavingLimits2 0W
Peak shaving mode DisChgPeriod1 DisChgPeriod2 >ChargeFromGrid	ChargeFromGrid ChargeFromGrid Disable	ChargeFromGrid ChargePowerLimits 1000W
ChargeFromGrid MAX_SOC 50%	Peak shaving mode DisChgPeriod2 ChargeFromGrid >Reserved_SOC	ReservedSOC Reserved_SOC 50%

9) Dry Contact

When the user uses the inverter communication control external device function, you can enter here to set the parameters of the external response control. For the setting method, please refer to the user manual of the compatible external device. If the user uses the inverter dry contacts to control external devices (such as heat pumps) through the Adapter box, please refer to the Adapter box quick installation manual to set the parameters here.

Load Management > Mode Select Disable
--

10) User Password

The default password for the end user is "0000", where you can reset the new password and press the up/down key to increase or decrease the value. Press "Enter" to confirm the value and jump to the next digit. When all passwords have been entered and confirmed, press "OK" to set the password successfully.

User Password > 0 0 0 0

➤ Advance settings

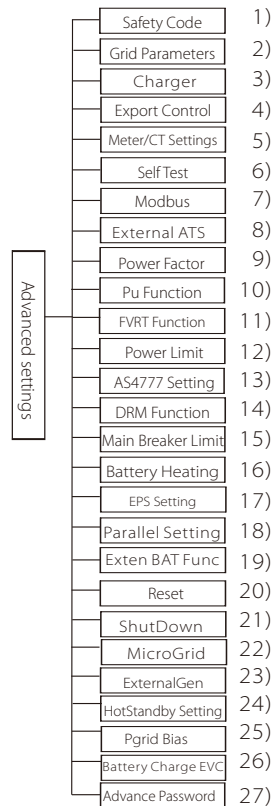

All advanced settings can be set here, such as battery, grid, EPS(Off-grid), etc.. "Advanced" setting is generally customization and resetting for battery and grid. Each part has lower level parts. Please contact your installer or factory and enter the installer password..

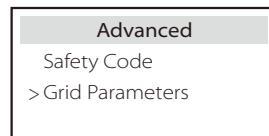

1) Safety Code

User can set safety standard according to different countries and grid tied. There are now several standards to choose from. (There may be changes in

2) Grid Parameters

Here you can set the protection value of grid voltage and frequency. The default value is the specified value under the current safety regulations, and the user cannot change it .

The display content will be displayed according to the requirements of local laws and regulations, which are constantly increasing. Please refer to the contents displayed on the inverter screen.

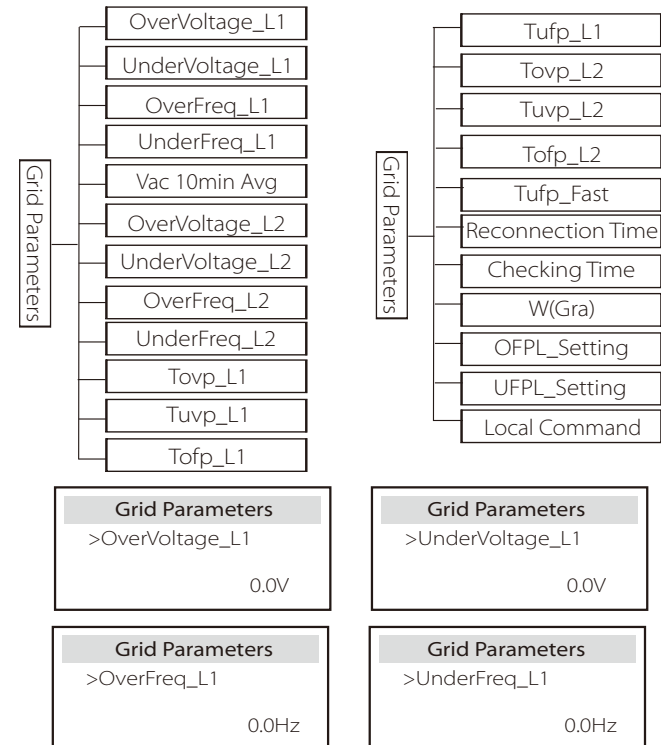

3) Charger

Here the user can set the parameters of "Charger" on this page, the inverter is compatible with both lithium battery and lead-acid battery. The default battery type is lithium, users can change it to lead-acid in actual usage. The relevant parameters needed to be set. For the detailed parameters, please refer to the contents display on the screen.

Charger Battery Type Lead Acid Lithium	Charger Lead Acid	
Charger Charge Equalization 00.0V	Charger Charge float 00.0V	Charger Discharge Cut 00.0V
Charger Discharge BackUp 00.0V	Charger >Max Charge Current: 30A	Charger >Max Discharge Current: 30A
Charger Charge upper limit 100%	Charger Lithium	Charger >Max Charge Current: 30A
Charger >Max Discharge Current: 30A	Charger Charge upper limit 100%	

4) Export Control

This feature allows the inverter to control the amount of electricity output to the grid.

The factory value is the default and can be changed by the user. The user value set by setup must be less than the maximum. If the user does not want to supply power to the grid, set it to 0.

When Safety codes related to Australia are chosen, this item won't show on the screen.

Export Control User value: 0W
--

5) Meter/CT Setting

The user needs to select the CT or electricity meter to connect the inverter here. Select the address of the meter. CT does not need to select the address. In the Meter/CT Settings box, there are two options (Negative and Positive) available for users. If the Meter is reversely connected, please click the Negative tab.

CT/Meter Setting > Select Meter	CT/Meter Setting > Meter 1Addr: xxxxxxx
--	--

CT/Meter Setting > Meter2/C1 Direction Positive
--

6) Self Test (only for CEI 0-21)

The self test function allows users to test the following items. "Full test", "Ovp(59.S2) test", "Uvp (27.S1) test", "Uvp (27.S2) test", "Ofp (81>.S1) test", "Ufp (81<.S1) test", "Ofp (81>.S2) test", "Ufp (81<.S2) test", "Ovp10 (59.S1) test". In the self-test interface, the user can select "all tests" or a single test item for testing.

Before testing, make sure that the inverter is connected to the grid. All tests take about 6 minutes. And it will display "Success" and then "Delivery".

For a single test item, it takes about a few seconds or minutes. Click "Test Report" to view the test results of all items.

Self Test ALL Test Test report Uvp(27.S1) test	>Ofp2(81>.S2)result Ft: 51.50Hz Tt:1000ms Fs: 0.00Hz To: 998ms F0: 0.00Hz pass
>Ovp2(59.S2)result Vt: 264.5V Tt: 300ms Vs: 0.0V To: 200ms V0: 0.0V pass	>Ofp2(27.S2)result Vt: 92.0V Tt: 200ms Vs: 0.0V To: 196ms V0: 0.2V pass
>Uvp2(27.S1)result Vt: 195.5V Tt: 400ms Vs: 0.0V To: 200ms V0: 0.0V pass	>Ofp2(81>.S1)result Ft: 50.50Hz Tt: 100ms Fs: 0.00Hz To: 96ms F0: 0.2Hz pass
>Ufp2(81<.S1)result Ft: 49.50Hz Tt: 100ms Fs: 0.00Hz To: 98ms F0: 0.02Hz pass	>Ufp2(81<.S2)result Ft: 47.50Hz Tt: 400ms Fs: 0.00Hz To: 3999ms F0: 0.02Hz pass
>Ovp10(59.S1)result Vt: 253.0V Tt: 600ms Vs: 0.0V To: 598ms V0: 0.0V pass	

7) Modbus

Select the functional use of the external communication port. COM for normal Modbus communication, "EV Charger" for communicating with the EV Charger, DataHub for communicating with DataHub.

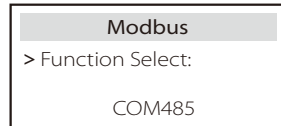

Here you select the baud rate of the external communication protocol, the default location of 19200 and 485 addresses.

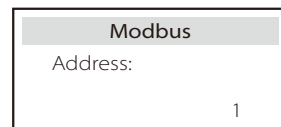
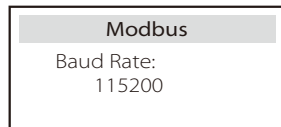

8) External ATS

If the Matebox with the inverter has built-in ATS, that is to say the advanced version, you need to enable this function. In other cases, disable this function is required.

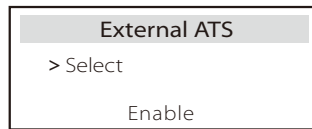

9) Power Factor (applicable to specific countries, please refer to local grid requirements.)

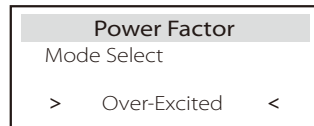
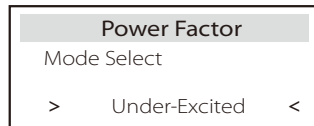
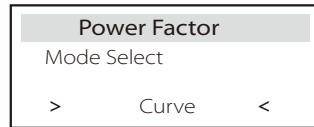
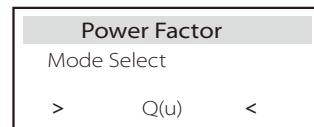
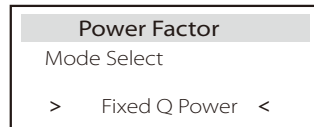
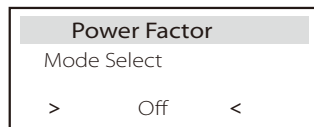

Mode	Comment
Off	-
Over-Excited	PF value
Under-Excited	PF value
Curve	Upper limit
	Lower limit
	Power Upper
	Power Lower
	PFLockInPoint (CEI 0-21 only)
	PFLockOutPoint (CEI 0-21 only)
	3Tau
Q(u)	VoltRATIO 1 (AS4777.2 only)
	VoltRATIO 4 (AS4777.2 only)
	QRESPONSEV2 (AS4777.2 only)
	QRESPONSEV3 (AS4777.2 only)
	QRESPONSEV4 (AS4777.2 only)
K Value (CEI 0-21 only)	
Fixed Q Power	Q Power

For VDE ARN 4105, the curve $\cos \varphi = f(P)$ should refer to curve A. The set default value is shown in curve A.

For TOR, the curve $\cos \varphi = f(P)$ should be curve B. The set default value is shown in curve B.

For CEI 0-21, the default value of PFLockInPoint is 1.05. When $V_{ac} > 1.05V_n$, $P_{ac} > 0.2 P_n$, curve $\cos \varphi = f(P)$ corresponds to curve C.

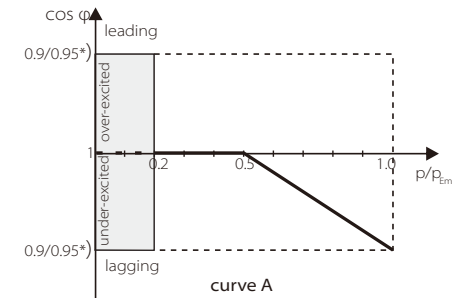

*) If the grid-connected power of the inverter $\leq 4.6kW$, the Power Factor is 0.95 at 1.0 power; if the grid-connected power of the inverter $> 4.6kW$, the Power Factor is 0.90 at 1.0 power.

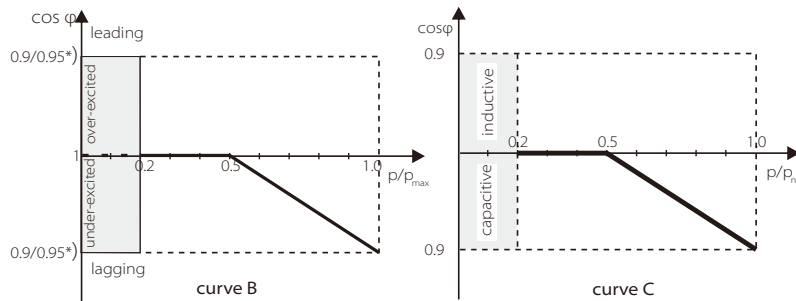

*) Depend on the required Q capacity

- Reactive power control, reactive power standard curve $Q = f(V)$

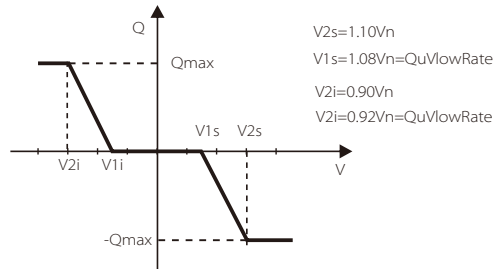

10) PU Function (applicable to specific countries, please refer to local grid requirements)

The PU function is a volt-watt response mode required by certain national standards such as AS4777.2. This function can control the active power of the inverter according to the grid voltage.

Selecting "Enable" means that this function is turned on and is the default value.

Select "Disable" to deactivate the function.

PU Function	
>PuFunction	Enable

PU Function	
Response V2	220.0V

PU Function	
Response V3	250.0V

PU Function	
Response V4	265.0V

11) FVRT Function (apply to 50549)

Here you can enable or disable the FVRT Function.

FVRT Function	
Func Select	Disable/Enable

12) Power limit

Power limit function, the maximum power of the AC port can be set by

Power Limit	
>Proportion	1.00

13) AS4777 Setting

It is the same as the function of Export Control, but it's only applicable to Australia and New Zealand.

AS4777 Setting	
>Export Control	General Control

Export Control	
>Soft Limit	Enable

Export Control	
>Soft Limit Value	00000W

14) DRM function (applied to NZS4777.2)

The DRM function is a demand response method required by the NZS4777.2 standard and is only applicable to NZS4777.2.

The default value is "enable". Select "Disable" to disable this function.

DRM Function	
>Function Control	Enable

15) Main Breaker Limit

For power limit of smart meter or CT, the current must be set in line with the utility's contract requirements. In case of failure to set, it may cause a circuit breaker fault of main switchboard, adversely affecting the charging or discharging of battery. Click Main Breaker Limit to enter the setting interface, and then choose the corresponding amperage according to the utility's requirements.

Main Breaker Limit	
>Current	40A

16) Battery Heating

If the battery heating function is needed, you can enable it here. After you enable this function, as long as PV is available, the battery system will be heated.

Once the battery system temperature is lower than 0°C, the battery will be heated until 10°C.

Then you need to set the heating periods that the battery system needs to be heated.

There are two periods can be set.

During the heating periods, if BAT actual SOC>35%*, the priority of heating energy source will be in the sequence of PV>BAT>grid.

During the heating periods, if BAT actual SOC<35%*, the priority of heating energy source will be in the sequence of PV>grid.

Out of the heating periods, the heating energy source is PV merely.

*The inverter will synchronize to consider the battery cell voltage.

Battery Heating	Battery Heating
>Func Select: Enable/Disable	>Heating Period 1 Start Time 00:00
Battery Heating	Battery Heating
>Heating Period 1 End Time 00:00	>Heating Period 2 Start Time 00:00
Battery Heating	
>Heating Period 2 End Time 00:00	

17) EPS Setting

Users can set the frequency selection in the EPS mode here, and set the minimum SOC and minimum ESC SOC.

When the device is in EPS mode, once the battery SOC is lower than the Min SOC of the inverter, it displays "Bat Power Low". When the SOC of the battery reaches the Min Esc SOC, the inverter will automatically enter EPS mode. The default value of Min Esc SOC is 30% and Min Esc SOC can set between 15% and 100%.

EPS Setting	EPS Setting
> Frequency 50Hz	>Frequency 60Hz
EPS Setting	EPS Setting
> Min SOC 10%	> Min ESC SOC 30%

18) Parallel Setting (a function for parallel operation)

If a parallel operation is required, the user may set it with Parallel Setting.

Parallel Setting	Parallel Setting
> Status setting Free > Master <	> Status setting Free Free

19) Exten BAT Func

This function is for extending new batteries. This setting shall be invalid under the EPS mode. When it is on-grid, enabling this setting will make the inverter charge or discharge the battery SOC to about 40%, which is convenient for adding new batteries.

Exten BAT Func
Select Enable/Disable

20) Reset

Users can reset the reset error log, meter power, inverter power, and restore factory settings here.

Reset Error Log	Reset Meter/CT_1
>Reset Yes	>Reset Yes
Reset Meter/CT_2	Reset INV Energy
>Reset Yes	>Reset Yes
Factory Reset	Wifi Reset★
>Reset Yes	>Reset Yes

★ "WiFi Reset" is only supported by inverters whose 6th digit of the SN is "A" or "C" and whose hardware has a WiFi reset circuit.

21) ShutDown

ShutDown is an Enable Switch. If the user wanna use ShutDown, the Enable mode can be set.

ShutDown
ShutDown > Enable <

22) MicroGrid

MicroGrid
>MicroGrid Enable

23) ExternalGen

The set value of power must meet the following two conditions when the maximum charging power of batteries is to be set.

- 1) The value of Max Charge Power is less than that of rated power of the generator minus total load power.
- 2) The value of Max Charge Power is less than or equals that of rated power of the inverter.

External Gen Function Control Enable Disable	External Gen Function Control ATS Control	External Gen MaxChargePower 0W
External Gen Forced Charge Period Start Time 00:00	External Gen Forced Charge Period End Time 00:00	External Gen Allowed Disc Period Start Time 00:00
External Gen Allowed Disc Period End Time 00:00	External Gen Char&Disc Period2 Enable Disable	External Gen Forced Charge Period Start Time 2 00:00
External Gen Forced Charge Period End Time 2 00:00	External Gen Allowed Disc Period Start Time 2 00:00	External Gen Allowed Disc Period End Time 2 00:00
External Gen Charge from Gen Enable/Disable	Charge from Gen Charge battery to 10%	ExternalGen Function Control Dry Contact
ExternalGen MaxChargePower 0W	ExternalGen Start Gen Method reference soc/immediately	ExternalGen Switch on SoC 0%
ExternalGen Switch off SoC 0%	ExternalGen MaxRunTime Min	ExternalGen MaxRestTime Min
ExternalGen Char&Disc Period Enable Disable	ExternalGen Charg Period Start Time 00:00	ExternalGen Charg Period End time 00:00

ExternalGen Allowed Disc Period Start Time 00:00	ExternalGen Allowed Disc Period End Time 00:00	ExternalGen Char&Disc Period2 Enable Disable
External Gen Charge from Gen Enable Disable	ExternalGen Charge battery to 10%	

24) HotStandby Setting

This function is mainly to save the capacity of the battery. When PV has no power and the inverter has no output power, the inverter will enter "HotStandby" status. When the power of loads is higher than 100W, the inverter will exit "HotStandby" status. It is "Disable" by default, setting "Enable" the inverter will enter "HotStandby"

HotStandby Setting
HotStandby Setting Enable/Disable

25) Pgrid Bias

Here you can set whether to discharge more to the grid or prefer to take power from the grid. If disable is selected, means no preference. If Grid is selected, the inverter will be biased to discharge the mains; if INV is selected, the inverter will be biased to take power from the

Pgrid Bias
>Pgrid Bias Disable/Grid/INV

26) Battery Charge EVC

Here you can set "Enable" to allow the battery to discharge energy to EV Charger. When you set "Disable", battery discharging energy to EV Charger is not allowed.

Battery charge EVC
Disable/Enable

27) Advance Password

Here you can reset the advanced password. "Set OK!" is displayed on success, and "Setting Failed!" will also be displayed on failure.

Advance Password Set OK!	Advance Password Setting failed!
------------------------------------	--

➤ About

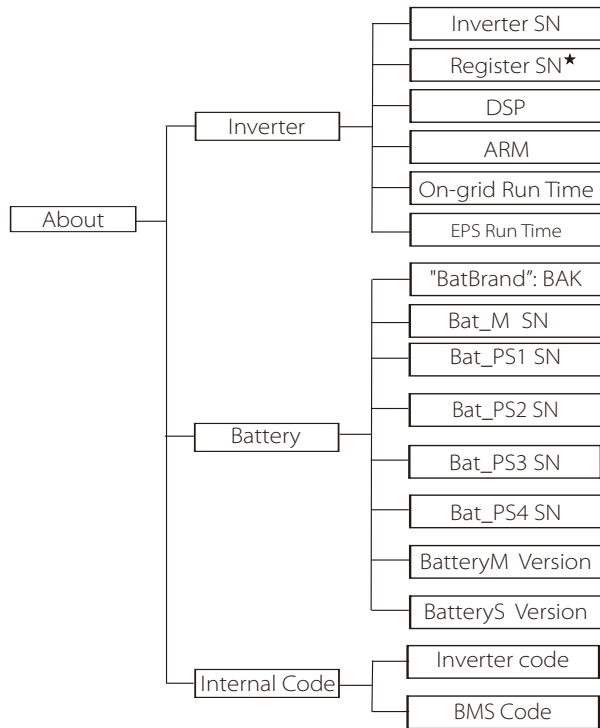

a) About

Here you can see some basic information of the inverter and battery. Such as the inverter and battery SN number, software version number, and system run time.

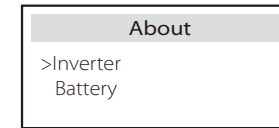

Inverter

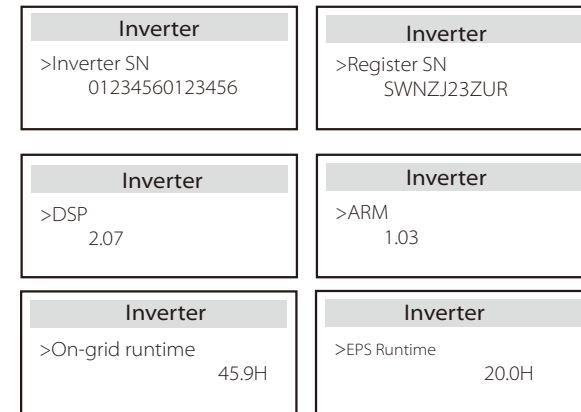

★ Register1 SN: Represents the serial number of external monitoring equipment, such as WiFi Dongle, LAN Dongle and GPRS Dongle.

Battery

Battery	Battery
>BatBrand: BAK	>Bat_M SN 6S012345012345
Battery	Battery
>Bat_PS1 SN 6S012345012345	>Bat_PS2 SN 6S012345012345
Battery	Battery
>Bat_PS3 SN 6S012345012345	>Bat_PS4 SN 6S012345012345
Battery	Battery
>BatteryM Version 2.01	>BatteryS Version 2.01

Internal Code

Internal Code	Internal Code
>Inverter code 01 00 01 xx	>BMS code
Internal Code	Internal Code
>BAT-M 2.01	>BAT-S1 1.01 50
Internal Code	Internal Code
>BAT-S2 1.01 50	••• >BAT-S8 1.01 50

9 Troubleshooting

9.1 Troubleshooting

This section contains information and procedures for resolving possible problems with this inverter, and provides you with troubleshooting tips to identify and solve most problems that may occur in this inverter. This section will help you narrow down the source of any problems you may encounter. Please read the troubleshooting steps below. Check the warning or fault information on the system control panel or the fault code on the inverter information panel. If a message is displayed, log it before doing anything further. Try the solutions indicated in the table below.

Number	Faults	Diagnosis and solution
IE 001	TZ Protect Fault	Overcurrent fault. <ul style="list-style-type: none"> • Wait for a while to check if you're back to normal. • Disconnect batteries, reconnect. • Or ask for help from the installer if it can not return to normal.
IE 002	Grid Lost Fault	<ul style="list-style-type: none"> • Check grid input voltage if it's within normal range. • Or ask the installer for help.
IE 003	Grid Volt Fault	Power grid voltage overrun <ul style="list-style-type: none"> • Wait a moment, if the utility returns to normal, the system will reconnect. • Please check if the grid voltage is within normal range. • Or ask the installer for help.
IE 004	Grid Freq Fault	Electricity frequency beyond range <ul style="list-style-type: none"> • If the utility returns to normal, the system reconnects. • Or ask the installer for help.
IE 006	Bus Volt Fault	<ul style="list-style-type: none"> • Press the "ESC" key to restart the inverter. • Or ask the installer for help.
IE 007	Bat Volt Fault	Battery voltage fault <ul style="list-style-type: none"> • Check battery input voltage if it's within normal range • Or ask the installer for help.
IE 008	AC10M Volt Fault	<ul style="list-style-type: none"> • The grid voltage was out of range in the last 10 minutes. • The system will return to normal if the grid returns to normal. • Or ask the installer for help.

Number	Faults	Diagnosis and solution
IE 009	DCI OCP Fault	DCI overcurrent protection fault. <ul style="list-style-type: none"> • Wait for a while to check if it's back to normal. • Or ask the installer for help.
IE 010	DCV OVP Fault	DCV EPS(Off-grid) overvoltage protection failure. <ul style="list-style-type: none"> • Wait for a while to check if it's back to normal. • Or ask the installer for help.
IE 011	SW OCP Fault	Software Detection of Over current Fault. <ul style="list-style-type: none"> • Wait for a while to check if it's back to normal. • Shut down battery and grid connections • Or ask the installer for help.
IE 012	RC OCP Fault	Over current protection fault. <ul style="list-style-type: none"> • Check the impedance of DC input and AC output. • Wait for a while to check if it's back to normal. • Or ask the installer for help.
IE 013	Isolation Fault	Insulation Fault <ul style="list-style-type: none"> • Please check the wire insulation for damage. • Wait for a while to check if it's back to normal. • Or ask the installer for help.
IE 014	Temp Over Fault	Temperature beyond limit <ul style="list-style-type: none"> • Check if ambient temperature exceeds the limit. • Or ask the installer for help.
IE 015	Bat Con Dir Fault	EPS(Off-grid) mode current is too strong. <ul style="list-style-type: none"> • Ensure that the load power is within the EPS(Off-grid) power range. • Check for any non-linear load connections on the EPS(Off-grid). • Move this load to check for recovery. • Or ask for help from the installer if it can not return to normal.
IE 016	EPS Overload Fault	EPS(Off-grid) over load fault. <ul style="list-style-type: none"> • Shutdown the high-power device and press the "ESC" key to restart the inverter. • Or ask for help from the installer if it can not return to normal.
IE 017	OverLoad Fault	On-grid mode over load <ul style="list-style-type: none"> • Shutdown the high-power device and press the "ESC" key to restart the inverter. • Or ask for help from the installer if it can not return to normal.
IE 018	BatPowerLow	<ul style="list-style-type: none"> • Close the high-power device and press the "ESC" key to restart the inverter. • Please charge the battery to a level higher than the protection capacity or protection voltage
IE 019	BMS Lost	Battery communication loss <ul style="list-style-type: none"> • Check that the communication lines between the battery and the inverter are properly connected. • Or ask for help from the installer if it can not return to normal.
IE 020	Fan Fault	Fan Fault <ul style="list-style-type: none"> • Check for any foreign matter that may have caused the fan not to function properly. • Or ask for help from the installer if it can not return to normal.
IE 021	Low Temp	Low temperature fault. <ul style="list-style-type: none"> • Check if the ambient temperature is too low. • Or ask for help from the installer if it can not return to normal.

Number	Faults	Diagnosis and solution
IE 022	ARM Unmatched	ARM software version mismatch Fault <ul style="list-style-type: none"> • Update the software and press the ESC" key to restart the inverter. • Or ask for help from the installer if it can not return to normal .
IE 023	Other Device Fault	Other device Fault <ul style="list-style-type: none"> • Update the software and press the ESC" key to restart the inverter. • Or ask for help from the installer if it can not return to normal .
IE 025	InterComms Error	<ul style="list-style-type: none"> • Internal communication errors • Shut down battery and grid connections. • Or ask for help from the installer if it can not return to normal.
IE 026	Inv EEPROM Fault	Inverter EEPROM Fault. <ul style="list-style-type: none"> • Shut down battery and grid, reconnect. • Or ask for help from the installer if it can not return to normal.
IE 027	RCD Fault	Fault of Residual Current Device <ul style="list-style-type: none"> • Check the impedance of DC input and AC output. • Disconnect batteries and reconnect. • Or ask for help from the installer if it can not return to normal.
IE 028	Grid Relay Fault	Electrical relay failure <ul style="list-style-type: none"> • Disconnect PV+ PV- grid and batteries and reconnect. • Or ask for help from the installer if it can not return to normal.
IE 029	EPS Relay Fault	EPS(Off-grid) relay failure <ul style="list-style-type: none"> • Disconnect batteries and reconnect. • Or ask for help from the installer if it can not return to normal.
IE 031	ChargerRelayFault	Charge relay fault <ul style="list-style-type: none"> • Press the ESC" key to restart the inverter. . • Or ask for help from the installer if it can not return to normal.
IE 032	EarthRaleyFault	EPS(Off-grid) earth relay fault <ul style="list-style-type: none"> • Press the ESC" key to restart the inverter. . • Or ask for help from the installer if it can not return to normal.
IE 101	PowerTypeFault	Power type fault <ul style="list-style-type: none"> • Upgrade the software and press the ESC" key to restart the inverter. • Or ask for help from the installer if it can not return to normal.
IE 102	Port OC Warning	EPS(Off-grid) port over current fault <ul style="list-style-type: none"> • Check that the EPS(Off-grid) load does not exceed the system requirements, and press the ESC" key to restart the inverter. . • Or ask for help from the installer if it can not return to normal.

Number	Faults	Diagnosis and solution
IE 103	Mgr EEPROM Fault	Manager EEPROM Fault. <ul style="list-style-type: none"> • Shut down battery and grid, reconnect. • Or seek help from the installer if it can not return to normal.
IE 104	DSPunmatched	DSP version error. <ul style="list-style-type: none"> • Check that the DSP1 version matches • Or seek help from the installer if it can not return to normal.
IE 105	NTC Sample Invalid	NTC invalid <ul style="list-style-type: none"> • Make sure the NTC is properly connected and the NTC is in good condition. • Please confirm that the installation environment is normal • Or ask for help from the installer, if it can not return to normal.
IE 106	Bat Temp Low	Battery temp low <ul style="list-style-type: none"> • Check the battery installation environment to ensure good heat dissipation. • Or ask for help from the installer, if it can not return to normal.
IE 107	Bat Temp High	Battery temp high <ul style="list-style-type: none"> • Check the battery installation environment to ensure good heat dissipation. • Or ask for help from the installer, if it can not return to normal.
IE 109	Meter Fault	Meter error <ul style="list-style-type: none"> • Please check that the instrument is working properly. • Or seek help from the installer if it can not return to normal.
IE 110	BypassRaleyFault	Bypass relay fault <ul style="list-style-type: none"> • Press the ESC* key to restart the inverter. . • Or ask for help from the installer if it can not return to normal.
BE 001	BMS_External_Err	Battery Error - External Communication Fault <ul style="list-style-type: none"> • Please contact the battery supplier.
BE 002	BMS_Internal_Err	Battery Error - Internal Communication Fault <ul style="list-style-type: none"> • Please contact the battery supplier.
BE 003	BMS_OverVoltage	Over voltage in battery system <ul style="list-style-type: none"> • Please contact the battery supplier.
BE 004	BMS_LowerVoltage	Low voltage in battery system <ul style="list-style-type: none"> • Please contact the battery supplier.
BE 005	BMS_ChargeOCP	Battery fault - over charge fault <ul style="list-style-type: none"> • Please contact the battery supplier.
BE 006	BMS_DischargeOCP	Battery fault-discharge over current fault <ul style="list-style-type: none"> • Please contact the battery supplier.
BE 007	BMS_TemHigh	Over temperature in battery system <ul style="list-style-type: none"> • Please contact the battery supplier.
BE 008	BMS_TempSensor Fault	Battery temperature sensor malfunction <ul style="list-style-type: none"> • Please contact the battery supplier.

Number	Faults	Diagnosis and solution
BE 009	BMS_CellImblance	Battery Unbalanced Failure <ul style="list-style-type: none"> • Please contact the battery supplier.
BE 010	BMS_Hardware Protect	Battery hardware protection failure <ul style="list-style-type: none"> • Please contact the battery supplier.
BE 011	BMS_Circuit_Fault	Battery circuit failure <ul style="list-style-type: none"> • Restart the battery . • Please contact the battery supplier.
BE 012	BMS_ISO_Fault	Battery insulation failure <ul style="list-style-type: none"> • Check that the battery is properly grounded and restart the battery. • Please contact the battery supplier.
BE 013	BMS_VolSen_Fault	Battery voltage sensor fault <ul style="list-style-type: none"> • Please contact the battery supplier.
BE 014	BMS_TemppSen_Fault	Temperature sensor failure <ul style="list-style-type: none"> • Restart the battery. • Please contact the battery supplier.
BE 015	BMS_CurSensor Fault	Battery current sensor fault <ul style="list-style-type: none"> • Please contact the battery supplier.
BE 016	BMS_Relay Fault	Battery relay failure <ul style="list-style-type: none"> • Please contact the battery supplier.
BE 017	BMS_Type_Unmatch	Battery type failure <ul style="list-style-type: none"> • Upgrade the battery BMS software. • Please contact the battery supplier.
BE 018	BMS_Ver_ Unmatch	Battery version mismatch failure <ul style="list-style-type: none"> • Upgrade the battery BMS software. • Please contact the battery supplier.
BE 019	BMS_MFR_ Unmatch	Battery manufacturer did not match the fault <ul style="list-style-type: none"> • Upgrade the battery BMS software. • Please contact the battery supplier.
BE 020	BMS_SW_ Unmatch	Battery hardware and software mismatch failure <ul style="list-style-type: none"> • Upgrade the battery BMS software. • Please contact the battery supplier.
BE 021	BMS_M&S_ Unmatch	Battery master slave control mismatches <ul style="list-style-type: none"> • Upgrade the battery BMS software. • Please contact the battery supplier.
BE 022	BMS_CR_ NORespond	Battery charging request does not respond to a fault <ul style="list-style-type: none"> • Upgrade the battery BMS software. • Please contact the battery supplier.
BE 023	BMS_SW_ Protect	Battery slave software protection failure <ul style="list-style-type: none"> • Upgrade the battery BMS software. • Please contact the battery supplier.
BE 024	BMS_536_Fault	Battery fault-discharge over current fault <ul style="list-style-type: none"> • Please contact the battery supplier.
BE 025	BMS_SelfcheckErr	Over temperature in battery system <ul style="list-style-type: none"> • Please contact the battery supplier.

Number	Faults	Diagnosis and solution
BE 026	BMS_TempdiffErr	Battery temperature sensor malfunction • Please contact the battery supplier.
BE 027	BMS_BreakFault	Battery Unbalanced Failure • Please contact the battery supplier.
BE 028	BMS_Flash_Fault	Battery hardware protection failure • Please contact the battery supplier.
BE 029	BMS_Precharge_Fault	Battery precharge failure • Please contact the battery supplier.
BE 030	BMS_AirSwitch_Fault	Battery air switch failure • Check that the battery breaker is off. • Please contact the battery supplier.

If the information panel of your inverter does not show the fault light, check the following list to ensure the current installation status, correct operation.

- Is the inverter located in a clean, dry and well-ventilated place?
- Is the DC input circuit breaker open?
- Is the specification and length of the cable adequate?
- Are the input and output connections and wiring in good condition?
- Is the configuration set correct for your particular installation?

Please contact our customer service for further assistance. Please be prepared to describe the details of your system installation and provide the inverter serial number.

9.2 Routine Maintenance

Inverter do not require any maintenance or correction in most cases, but if the inverter often loses power due to overheating, this can be attributed to the following reason:

- heat sink behind the inverter is covered with dirt. If necessary, clean the cooling heat sink with a soft dry cloth or brush. Only trained and authorized professionals familiar with safety requirements can perform maintenance and maintenance work.

➤ Safety inspections

Safety checks should be conducted at least every 12 months, please contact the manufacturer to arrange for appropriate training, expertise, and practical experience in performing these tests. (Please note that this action is not covered by warranty).

These data should be recorded in the device log. If the equipment is not running properly or any test fails, the equipment must be repaired for details of safety inspections, refer to section 2 of this manual for safety instructions and European commission instructions.

➤ Regular maintenance

Only qualified people can do the following work.

In the process of using frequency converter, the manager should check and maintain the machine regularly. The specific operation is as follows.

1. Check whether the heat sink is covered with dirt, clean the inverter and absorb dust if necessary. This work should be performed from time to time.
2. Check whether the frequency converter indicator is normal, check whether the frequency converter button is normal, check whether the frequency converter display is normal. This inspection should be conducted at least every 6 months.
3. Check the input and output lines for damage or aging. This inspection should be conducted at least every 6 months.

10 Decommissioning

10.1 Disassemble the Inverter

- Remove DC input line and AC output line of inverter.
- Wait for at least 5 minutes to power off.
- Remove all cable connections from the inverter.
- Remove inverter from finger support the bracket.
- Remove the bracket if necessary.

10.2 Packaging

Load the inverter into the original package if possible.

- If the original package can not be found, you can also use the following requirements of the carton packaging:
Bearing capacity of more than 30kg;
Easy to carry;
Can completely seal the cover.

10.3 Storage and Transportation

Store the inverter in a dry, temperature -40°C~ 65°C environment.
Pay attention to less than four inverters on each stack board during storage and transportation.

10.4 Waste Disposal

If it is necessary to scrap the inverter or other related parts, be sure to send the waste inverter and packaging materials to the designated location for recycling by the relevant department.

11 Disclaimer

The series inverters are transported, used and operated under limited condition, such as environmental, electrical etc. We shall not be liable to provide the service, technical support or compensation under conditions listed below, including but not limited to:

- Inverter is damaged or broken by force majeure (such as earthquake, flooding, thunderstorm, lighting, fire hazard, volcanic eruption etc).
- Inverter's warranty is expired and not extended.
- Can't provide the inverter's SN, warranty card or invoice.
- Inverter is damaged by man-made cause. Inverter is used or operated against any items in local policy.
- Inverter's installation, configuration, commissioning doesn't follow the requirements mentioned in this manual.
- Inverter is installed, refitted or operated in improper ways mentioned in this manual without authority from us.
- Inverter is installed, operated under improper environment or electrical condition mentioned in this manual without authority from us.
- Inverter is changed, updated or disassembled on hardware or software without authority from us.
- Obtain the communication protocol from other illegal channels.
- Build monitoring, control system without authority from us.
- Connect to other brands batteries without authority from us.

SolaX will keep right to explain all the contents in this user manual.

Warranty Registration Form



For Customer (Compulsory)

Name Country

Phone Number Email

Address

State Zip Code

Product Serial Number

Date of Commissioning

Installation Company Name

Installer Name Electrician License No.

For Installer

Module (If Any)

Module Brand

Module Size(W)

Number of String Number of Panel Per String

Battery (If Any)

Battery Type

Brand

Number of Battery Attached

Date of Delivery Signature

Please visit our warranty website: <https://www.solaxcloud.com/#/warranty> to complete the online warranty registration or use your mobile phone to scan the QR code to register.

For more detailed warranty terms, please visit SolaX official website: www.solaxpower.com to check it.





PLEASE REGISTER THE WARRANTY IMMEDIATELY AFTER INSTALLATION!
GET YOUR WARRANTY CERTIFICATE FROM SOLAX!
KEEP YOUR INVERTER ONLINE & WIN SOLAX POINTS!

1

Open your camera app and point your device at the QR code



2

Wait for the camera to recognize the QR code



3

Click banner or notification when it appears on the screen



4

Warranty registration page will be loaded automatically

