

# Rapid Shutdown

XRSD-1C/XRSD-2C

XRSD-Core Kit

## User Manual

Version 2.0

[www.solaxpower.com](http://www.solaxpower.com)



eManual in the QR code or at <http://kb.solaxpower.com/>



# STATEMENT

---

## Copyright

Copyright © SolaX Power Network Technology (Zhejiang) Co., Ltd. All rights reserved.

No part of this manual may be reproduced, transmitted, transcribed, stored in a retrieval system, or translated into any language or computer language, in any form or by any means without the prior written permission of SolaX Power Network Technology (Zhejiang) Co., Ltd.

## Trademarks



SOLA<sup>POWER</sup> and other symbol or design (brand name, logo) that distinguishes the products or services offered by SolaX has been trademark protected. Any unauthorized use of above stated trademark may infringe the trademark right.

## Notice

All or part(s) of the products, features and services described in this document may not be within your scope of purchase or usage. Unless otherwise specified in the contract, the contents, information and recommendations in this document are provided as is, SolaX makes no kind of warranties, guarantees or representations expressly or implicitly.

The content of the documents is continually reviewed and amended, where necessary. However, discrepancies cannot be excluded. SolaX reserves the right to make improvements or changes in the product(s) and the program(s) described in this manual at any time without the prior notice.

The images contained in this document are for illustrative purposes only and may vary depending on product models.

Please visit the website [www.solaxpower.com](http://www.solaxpower.com) of SolaX Power Network Technology (Zhejiang) Co., Ltd. for more information.

SolaX reserves all the right for the final explanation.

# About This Manual

---

## Scope of Validity

This manual is an integral part of the SolaX XRSD-1C/2C and XRSD-Core Kit. It describes the detailed information, installation, and usage of the product. Please read it carefully before operating.

XRSD (SolaX Rapid Shutdown Device)	XRSD-1C* <sup>1</sup>
	XRSD-2C* <sup>1</sup>
Transmitter Kit	XRSD-Core Kit* <sup>2</sup>

**Note:**

\*1 "1C" means one input. "2C" means two inputs.

\*2 XRSD-Core Kit includes an outdoor enclosure, an 85~264V power supply, a transmitter, a SolaX module-level monitoring dongle (optional), and one core (two cores are optional).

## Target Group





The installation, maintenance and grid-related setting can only be performed by qualified personnel who

- Are licensed and/or satisfy state and local jurisdiction regulations.
- Have good knowledge of this manual and other related documents.



## Conventions

The symbols that may be found in this manual are defined as follows.

Symbol	Description
 <b>DANGER</b>	Indicates a hazardous situation which, if not avoided, will result in death or serious injury.
 <b>WARNING</b>	Indicates a hazardous situation which, if not avoided, could result in death or serious injury.
 <b>CAUTION!</b>	Indicates a hazardous situation which, if not avoided, could result in minor or moderate injury.
 <b>NOTICE!</b>	Provides tips for the optimal operation of the product.

## Change History

### Version 2.0 (2024/09/20)

Update ["3.4 XRSD Installation"](#)(Added recommended models of PV module connectors.)

Update ["Contact Information"](#)(Modified Australia email address.)

### Version 1.0 (2024/07/25)

Update ["3.4 XRSD Installation"](#) (Modify the location of serial number label)

### Version 0.0 (2024/05/10)

Initial release

# Table of Contents

---

<b>1</b>	<b>Safety</b> .....	<b>1</b>
	1.1 General Safety .....	1
	1.2 Safety Instructions .....	2
<b>2</b>	<b>Product Overview</b> .....	<b>4</b>
	2.1 System Description .....	4
	2.2 XRSD .....	5
	2.3 XRSD-Core Kit.....	6
	2.4 Symbols on the Device .....	7
<b>3</b>	<b>Installation</b> .....	<b>8</b>
	3.1 Safety Precautions .....	8
	3.2 Scope of Delivery.....	10
	3.3 Tools Requirement.....	12
	3.4 XRSD Installation.....	14
	3.5 XRSD-Core Kit Installation .....	20
	3.6 Conduit Drilling Guide .....	32
<b>4</b>	<b>Remote monitoring</b> .....	<b>33</b>
	4.1 Downloading and installing SolaX Cloud App .....	34
	4.2 App Registration and Login.....	34
	4.3 Site creation and Wi-Fi configuration .....	35
	4.4 Add XRSD .....	37
	4.5 Layout Settings .....	39
<b>5</b>	<b>Rapid Shutdown methods</b> .....	<b>42</b>
	5.1 Automatic shutdown .....	42
	5.2 Manual shutdown .....	42
<b>6</b>	<b>Technical Data</b> .....	<b>43</b>
<b>7</b>	<b>Appendix</b> .....	<b>45</b>

# 1 Safety

---

## 1.1 General Safety

Safety precautions must be strictly observed and followed to reduce the risk of personal injury and ensure a safe installation.

Before installing the device, carefully read, fully understand, and strictly follow the detailed instructions of the user manual, related sections of your inverter manual, and other regulations. And the safety instructions in this document are only supplements to local laws and regulations.

SolaX shall not be liable for any consequences caused by the violation of the storage, transportation, installation, and operation regulations specified in this document, including, but not limited to:

- Product damage due to force majeure, such as an earthquake, flooding, thunderstorm, lightning, fire hazard, volcanic eruption, etc.
- Product damage due to man-made causes
- Product used or operated against any items in local policy
- Failure to follow the operation instructions and safety precautions on the product and in this document
- Not install and operate within the [6 Technical Data \(P43\)](#) listed in their datasheets.
- Unauthorized modifications to the product or software
- Product damage caused during transportation by the customer
- Installation and commissioning are operated by unauthorized personnel who are not licensed and/or satisfy state and local jurisdiction regulations.

## 1.2 Safety Instructions

Please read these instructions carefully, and use this product correctly and safely. After reading, please keep these instructions in a safe place

### DANGER!

- When exposed to sunlight, high DC voltage will be generated by PV modules. Death or lethal injuries will occur due to electric shock.
- Do not attempt to install in inclement weather.
- The installation, wiring, or maintenance of the XRSD and XRSD-Core Kit can only be performed by qualified and experienced electricians.
- In order to avoid electric shock, do not open the enclosure of the XRSD. And the disassembly or maintenance of this product must be operated by a qualified person.
- Please perform all electrical installations in accordance with local codes.
- Use insulated tools when installing the device. Individual protective tools must be worn during installation, electrical connection, and maintenance.
- Do not touch non-insulated parts or cables.
- Do not install the XRSD in the situation of having been physically damaged or meeting the wiring standards any more.
- Do not use connectors from different manufacturers for risks of burns can be produced due to incompatible connectors.

### DANGER!

- Do not connect or disconnect the XRSD while the inverter is running. And turning off the inverter and/or the XRSD products may not reduce this risk. After disconnecting all power sources, internal capacitors within the inverter can remain charged for several minutes.
- If service is required, verify capacitors have discharged by measuring a voltage across inverter terminals before disconnecting wiring.
- After rapid shutdown activation, wait 30 seconds before disconnecting DC cables or turning off DC disconnect switch.
- Do not disconnect the PV module from the XRSD without first disconnecting the AC power of the XRSD-Core Kit.
- Make sure that the emergency stop button is pressed to cut off the AC power during installation.
- The power supply of the XRSD-Core Kit **MUST** be on the same AC branch circuit as the inverter in order to meet the rapid shutdown requirement.

 **WARNING!**

- Do not touch the XRSD when it is running. Surface high temperature may cause burns or personal injury.
- Do not attempt to repair the device if it is not working properly, please contact the SolaX Customer Support team. Any attempt to repair the XRSD will automatically void the warranty.

 **CAUTION!**

Keep the products away from children.

**NOTICE!**

All the labels and nameplate on the product shall be maintained clearly visible.

# 2 Product Overview

## 2.1 System Description

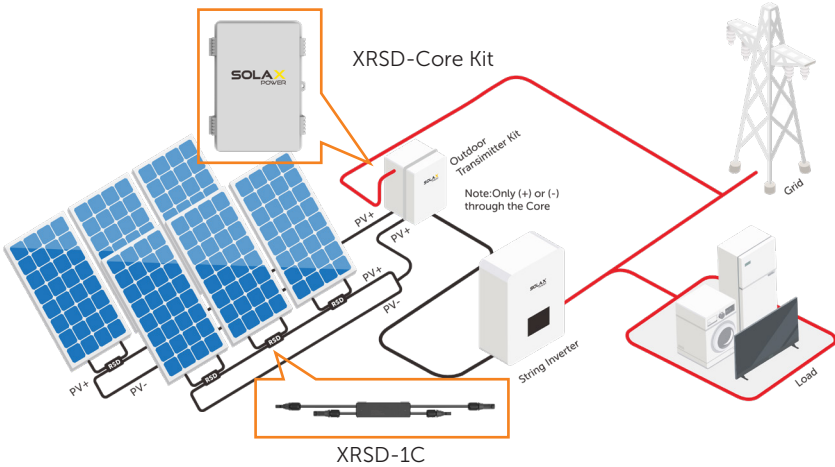

Figure 2-1 Enables rapid shutdown

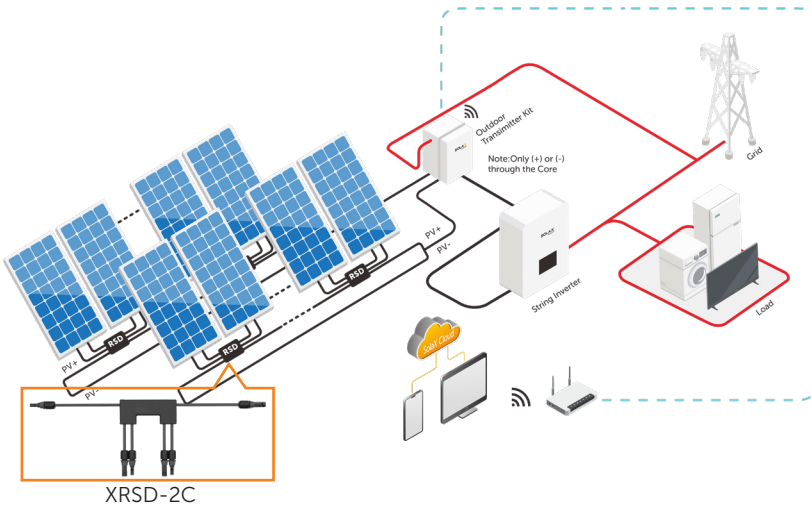

Figure 2-2 Enables rapid shutdown and monitoring  
(Be equipped with SolaX Pocket WIFI+LAN)

The XRSD is part of the rapid shutdown solution when paired with the XRSD-Core Kit.

The XRSD-Core Kit is installed in line with a solar PV inverter. It continuously sends a 'keep-alive' signal to the XRSD, ensuring a stable connection between the PV modules and the inverters. When XRSD receive an uninterrupted 'keep-alive' signal from the XRSD-Core Kit, they will operate the PV system as expected.

However, when power to the XRSD-Core Kit having been cut, this signal will cease and send every XRSD into shutdown mode to ensure system safety.

In this way, once the AC power supply of the XRSD-Core Kit is lost, the PV array enters rapid shutdown.

## 2.2 XRSD



XRSD-1C

XRSD-2C

As part of the SolaX rapid shutdown solution for PV system, XRSD-1C can be connected to one PV module while XRSD-2C can be connected to two.

### Highlights

- Meets NEC2017&NEC2020 690.12 requirements
- One or two inputs, Max. PV input current 20A
- PLC communication, rapid shutdown, and module-level monitoring with the SolaX Pocket WiFi+LAN
- Clip installation design, simple and convenient
- Lower power consumption and wider operating voltage range
- IP68 protection, long life cycle
- High security: overvoltage protection, overcurrent protection, overtemperature protection

### 2.3 XRSD-Core Kit

The XRSD-Core Kit, in tandem with XRSD, forms a crucial segment of the SOLAX rapid shutdown system. It includes an outdoor enclosure, an 85~264V power supply, a transmitter, a SolaX module-level monitoring dongle (optional), and one core (two cores are optional).



#### Highlights







- Meets NEC2017&NEC2020 (690.12)
- Realize rapid shutdown by simply powering off the XRSD-Core Kit or using enclosure external initiator
- Equipped with one or two cores (two cores are optional)
- IP65 protection
- Built in monitoring dongle,use SMART Website & App to access module-level data anywhere (Optional)



## 2.4 Symbols on the Device

The information on the device includes technical data and serial number of the device. Safety instructions on the label are listed and explained below :

Table 2-1 Description of symbols

Symbol	Description
	Danger of high voltages. Danger to life due to high voltages in the inverter!
	Danger. Risk of electric shock!
	Observe enclosed documentation.
	Double insulation symbol The device does not require a safety connection to electrical earth (ground).
	CE mark. The device complies with the requirements of the applicable CE guidelines.
	The device can not be disposed together with the household waste. Disposal information can be found in the enclosed documentation.

# 3 Installation

---

## 3.1 Safety Precautions

- Do not attempt to install in inclement weather.
- Only qualified personnel can perform the mechanical installation.
- Perform all electrical installations in accordance with local codes.
- Be equipped with individual protective tools and insulated tools when installing the XRSD and XRSD-Core Kit.
- Before installing or using XRSD, please read all instructions and warnings in the user manual, on the inverter system, and on the PV array.
- Follow the installation steps sequence to install. Damage caused by improper installation will not covered by warranty.
- Make sure the voltage, current and power specification of PV modules match the XRSD specifications.
- The maximum open circuit voltage of the PV module must not exceed the specified maximum input voltage of the XRSD.
- Never apply an external voltage source to a module or string that is equipped with XRSD.
- Connect XRSD to its respective modules before connecting its outputs in series.
- Install XRSD before powering on the XRSD-Core Kit.
- If parallel string connections are needed, first connect the XRSD to the PV modules, then connect all outputs of XRSD in series, and finally pass one side (+ or -) of the string through the transmitter to turn the system ON.
- Do not touch any live parts in the system, including the PV array, when the system has been connected to the electrical grid.

- After installing XRSD and XRSD-Core Kit, place the rapid shutdown system label within 1m of the emergency stop button or AC disconnect.

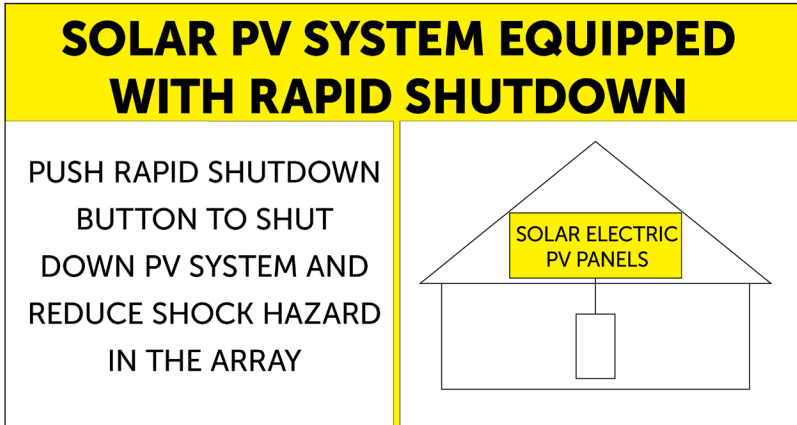
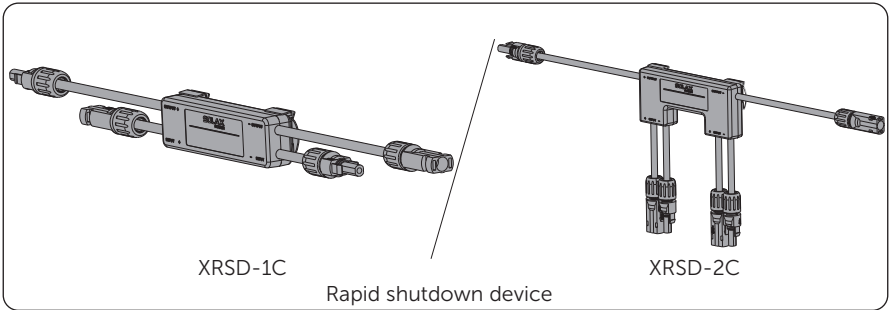

Figure 3-1 Rapid shutdown system label

### 3.2 Scope of Delivery

#### XRSD



\* Refer to the actual purchase quantity.

#### XRSD-Core Kit

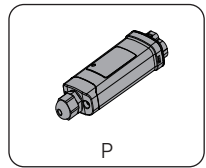
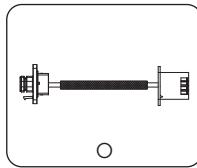
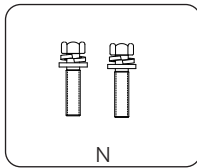
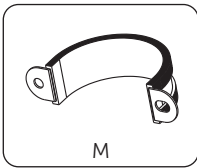
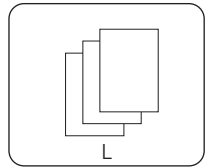
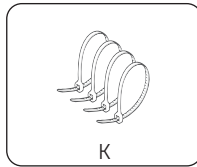
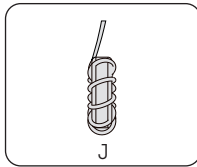
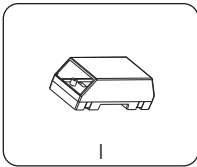
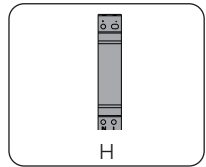
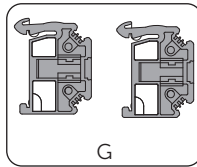
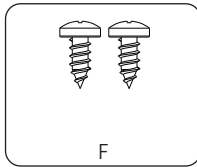
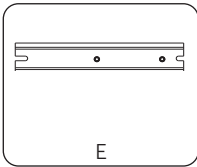
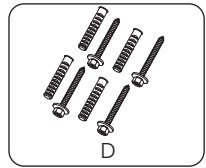
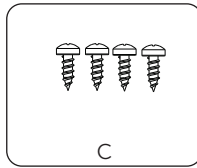
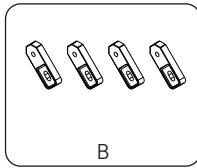
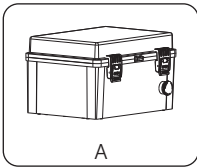

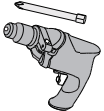





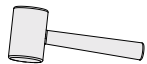

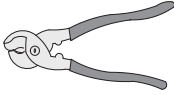
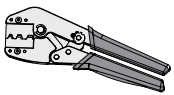

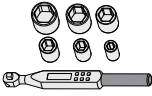





Table 3-1 XRS-D-Core Kit Packing list

Item	Description	Quantity	Remark	
A	Outdoor enclosure	1 pcs		
B	Mounting lugs	4 pcs		
C	Round head screws	4 pcs	For wall-mounting instalation	
D	Plastic wall anchor & Self-Tapping screw	4 pairs		
E	DIN35 rail	1 pcs		
F	M4.8*L10 screw	2 pcs	For securing DIN35 rail	
G	Clamps	2 pcs		
H	AC power Supply	1 pcs		
I	Transmitter	1 pcs		
J	Core	1/2 pcs(optional)		
K	Zip ties	4 pcs		
L	Documents	/		
Optional	M	Pipe strap	1 pcs	For securing SolaX Pocket WiFi+LAN
	N	M4*L16 screw	2 pcs	
	O	Signal cable	1 pcs	For transmitter and SolaX Pocket WiFi+LAN connection
	P	SolaX Pocket WiFi+LAN	1 pcs	

\* Refer to the actual delivery for the optional accessories.

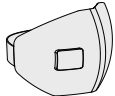

### 3.3 Tools Requirement

Installation tools include but are not limited to the following recommended ones. If necessary, use other auxiliary tools on site.

 <p>Torque screwdriver (Phillips head: PH2)</p>	 <p>Step drill bit</p>	 <p>Measuring tape</p>	 <p>Utility knife</p>
 <p>Hammer drill (drill bit: <math>\varnothing</math>10 mm)</p>	 <p>Marker</p>	 <p>Spirit level</p>	 <p>Rubber mallet</p>
 <p>Wire stripper</p>	 <p>Wire cutter</p>	 <p>Crimping tool for PV terminals</p>	 <p>PV connector disconnect tool</p>
 <p>Crimping tool for RJ45</p>	 <p>Torque wrench (Including 16 mm wrench)</p>	 <p>Flat-head screwdriver</p>	 <p>Multimeter (<math>&gt;</math> 1100 V DC)</p>
 <p>Safety gloves</p>	 <p>Safety boots</p>	 <p>Safety goggles</p>	 <p>Anti-dust mask</p>

## Additionally Required Materials

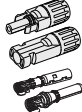
Table 3-2 Additionally required wires

No.	Required Material	Type	Quantity
1	PV cable	 According to the inverter type	/
2	MC4 PV Connector	 match with PV cable of inverter	/
3	Waterproof connectors with corrugated pipe	M12(for power cable port)	1 pcs
		M12(for Ethernet cable port)	1 pcs <sup>*1</sup>
		M25/ M32 <sup>*2</sup>	2 pcs (single core) 4 pcs (dual core)
4	power cable of XRSD-Core Kit	 2 Core, 0.5 A Conductor diameter:24 AWG Overall diameter:match with waterproof connectors	/

\*1 It is only required when the monitoring dongle (optional) is selected and a LAN connection is used. No need to prepare for Wi-Fi connection.

\*2 M25: Max. Number of Strings- 2.5  
M32: Max. Number of Strings- 5

### 3.4 XRSD Installation

**WARNING!**

- Make sure that the PV system is powered off.
- When installing XRSD, connect the input cables to the PV module before connecting the XRSD output cables in series.
- When disconnect XRSD, disconnect XRSD output cables from a string before disconnecting the XRSD input cables from the module junction box.
- Connectors from different manufacturers cannot be mated with each other.

**NOTICE!**

- Do not place the XRSD (including DC connectors) where exposed to the sun, rain or snow, even gap between modules.
- Allow a minimum of 1.5 cm of space between the roof and the XRSD enclosure in order to ensure ventilation and heat dissipation.
- Recommended model for PV module connectors:  
Dian Wei Electronic Technology (Vaconn Interconnection Solution)  
VP-D4B-CTSF4  
VP-D4B-CTSM4  
We are not responsible for any problems caused by using other models.

#### XRSD-1C

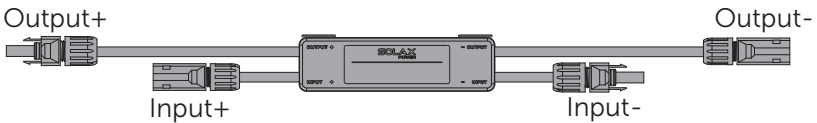

Figure 3-2 XRSD-1C terminal

**Step 1:** Remove the serial number label on the machine package and attach it on the corresponding position on the [installation map](#), which is used to model the physical layout of the roof module.

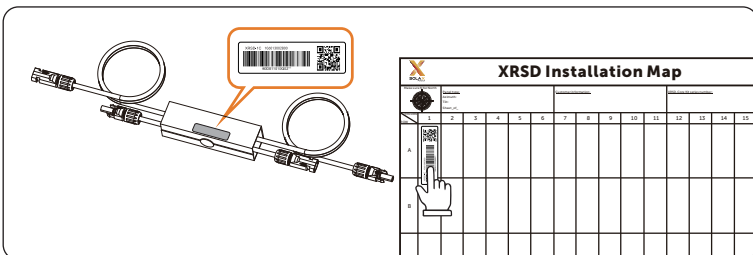

Figure 3-3 Stick the serial number label on the installation map



**Step 2:** Install XRSD on the frame of the PV module with mounting brackets.

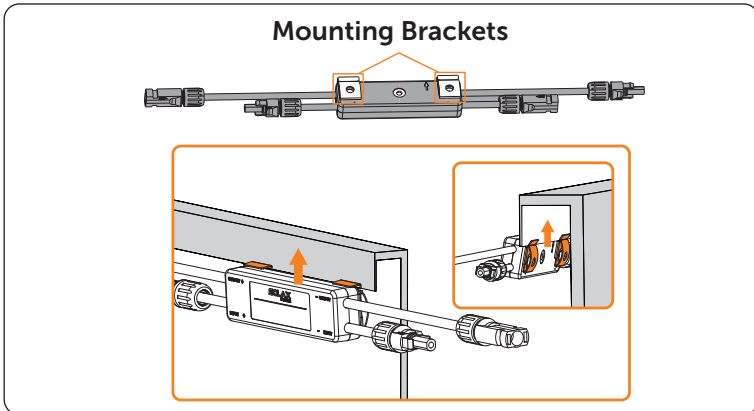

Figure 3-4 Buckle XRSD on the PV module frame

**Step 3:** Connect PV modules to XRSD inputs. Each XRSD must have a PV module connected to its inputs. You can use the DC extension cable if necessary.

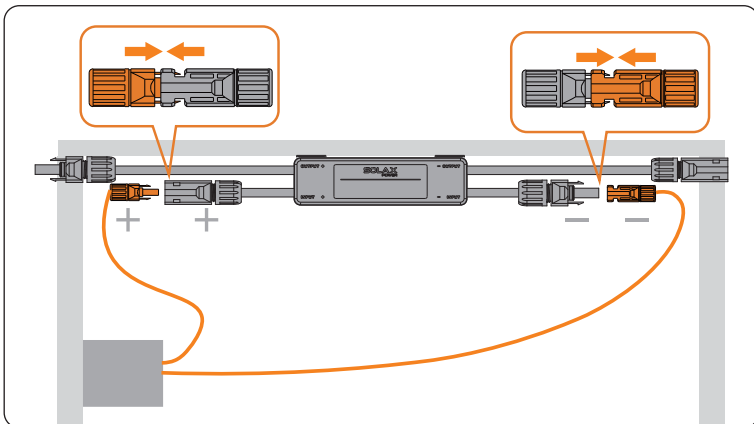

Figure 3-5 Connect PV modules to XRSD inputs

**Step 4:** Use a multimeter to measure the XRSD-1C output voltage. The output voltage should be 0.2~1.5V.

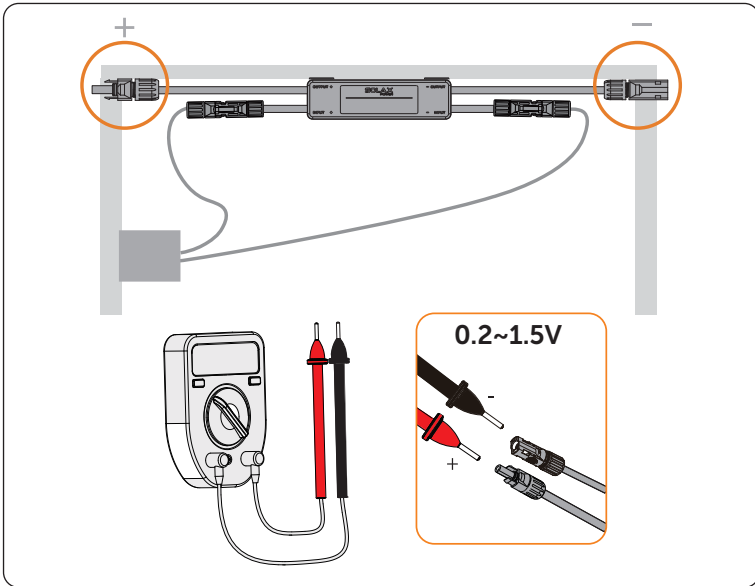

Figure 3-6 Measure the XRSD-1C output positive/negative voltage

**Step 5:** Connect the output of two adjacent XRSDs together.

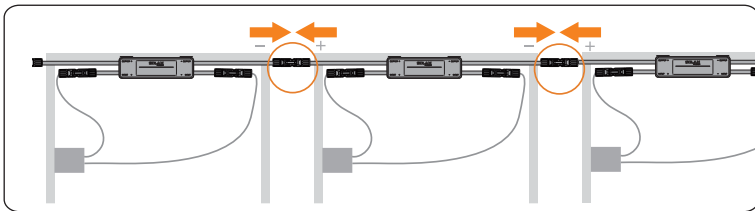

Figure 3-7 Connect XRSD outputs in series

## XRSD-2C

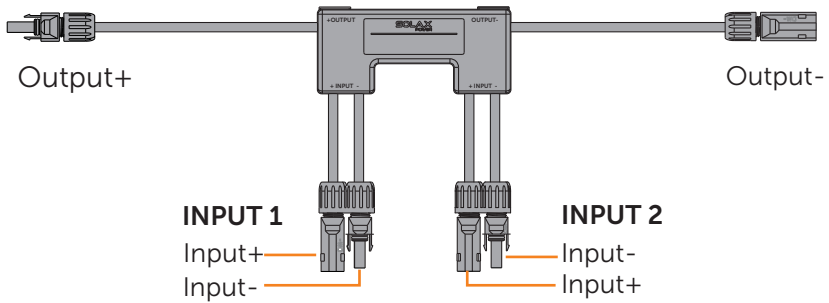

Figure 3-8 XRSD-1C terminal

**Step 1:** Remove the serial number label on the machine package and attach it on the corresponding position on the [installation map](#), which is used to model the physical layout of the roof module.

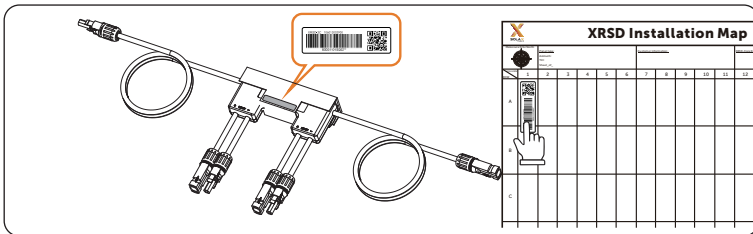

Figure 3-9 Stick the serial number label on the installation map

**Step 2:** Install XRSD on the frame of the PV module with mounting brackets.

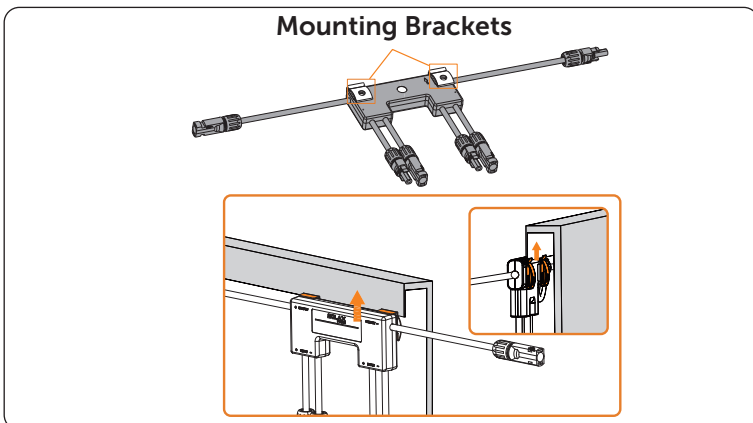

Figure 3-10 Buckle XRSD on the PV module frame

**Step 3:** Connect modules to XRSD inputs. Each XRSD must have a PV module connected to its inputs.  
You can use the DC extension cable if necessary.

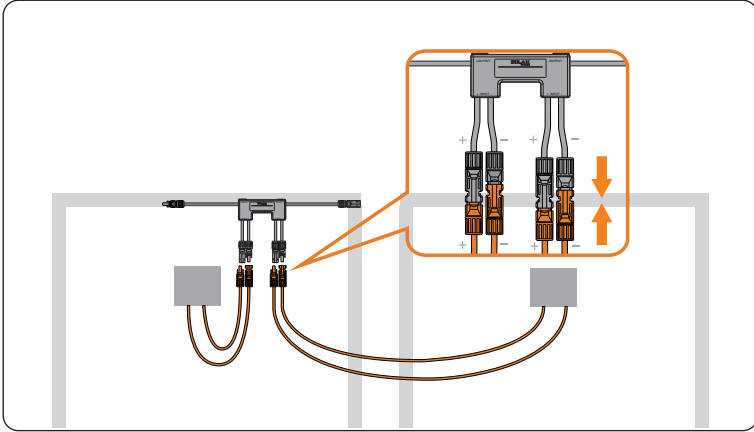

Figure 3-11 Connect PV modules to XRSD inputs

**Step 4:** Use a multimeter to measure the XRSD-2C output voltage. The output voltage should be 0.2~1.5V.

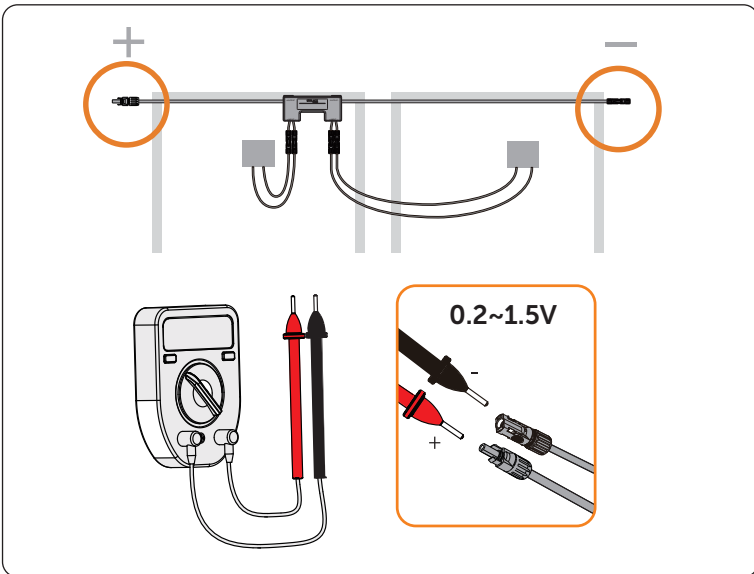

Figure 3-12 Measure the XRSD-2C output positive/negative voltage

**Step 5:** Connect the output of two adjacent XRSDs together.

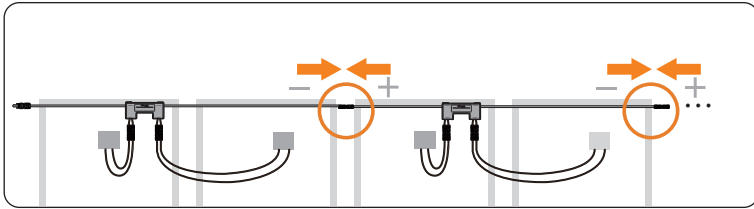

Figure 3-13 Connect XRSD outputs in series

### 3.5 XRSD-Core Kit Installation

#### XRSD-Core Kit box drilling

**Step 1:** Drill holes on the sides of the enclosure by using the drilling template. For detailed size please refer to ["3.6 Conduit Drilling Guide"](#)  
Remove burrs after drilling holes.

**Step 2:** Install the waterproof connectors to ensure the safety of the box.

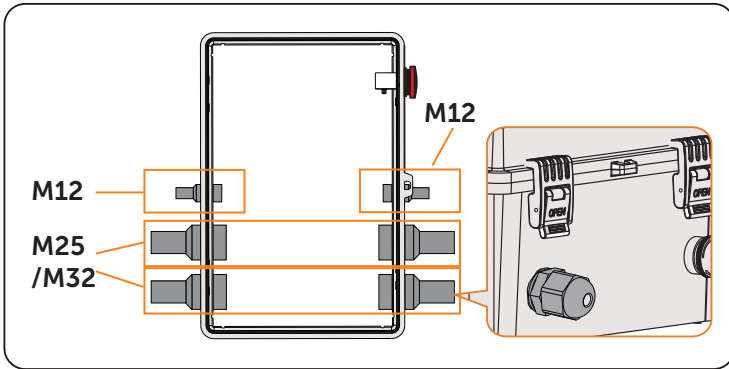

Figure 3-14 Install waterproof connectors

**Step 3:** Fix the mounting lugs with round head screws at the four corners of the box.

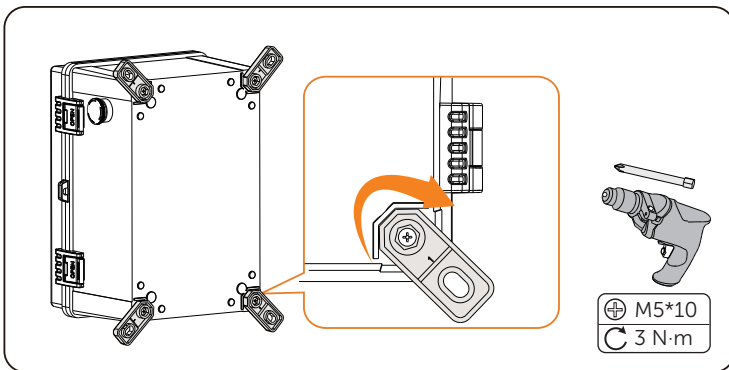
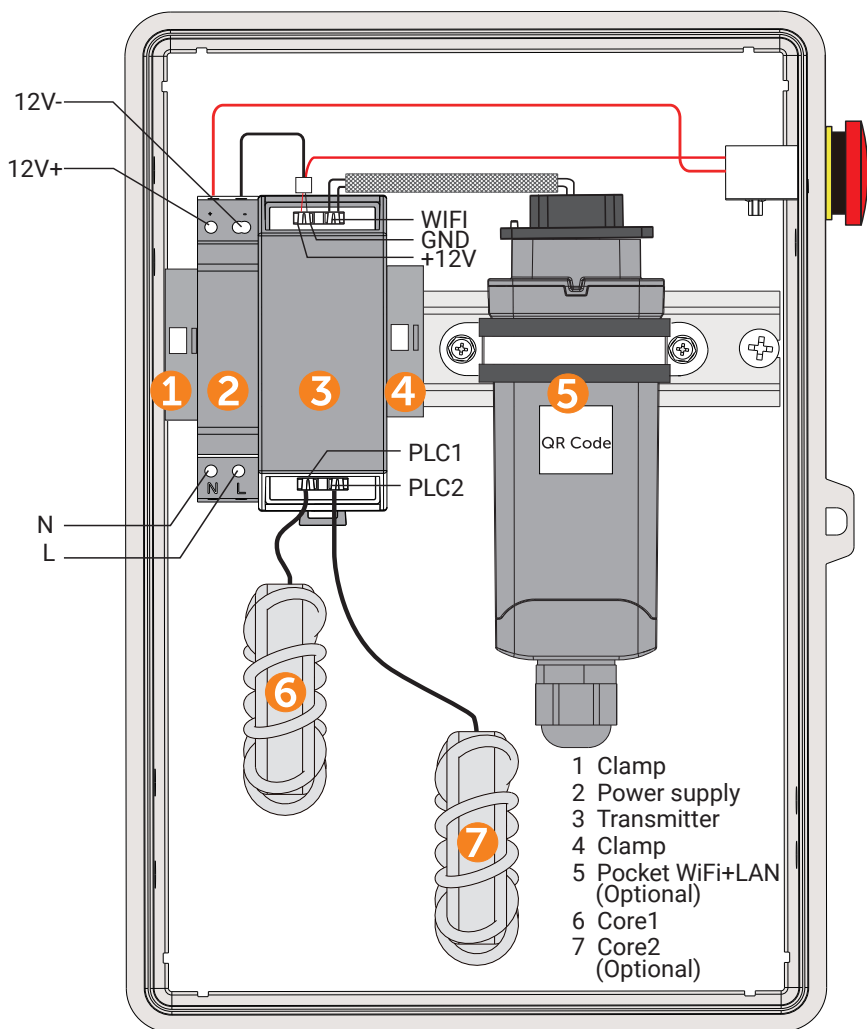

Figure 3-15 Fix mounting lugs with round head screws

## Box inside installation



Connection diagram

\* The illustrations in this manual all include an optional monitoring dongle.

**Step 4:** Fix the DIN rail onto **the second row** from the top.

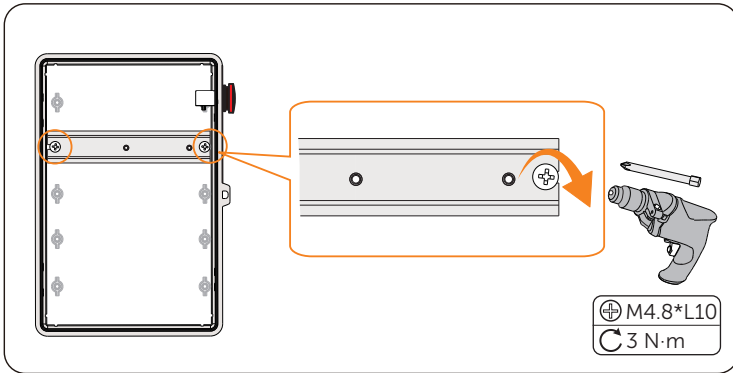

Figure 3-16 Fix DIN rail

**Step 5:** Mount AC power supply, transmitter, SolaX Pocket WiFi+Lan, and cores on DIN rail in the following order.

- 1) Fix a clamp at the left ends of the rail, then use a one-screwdriver to cock the edge of the clamp and snap it into the rail slot.

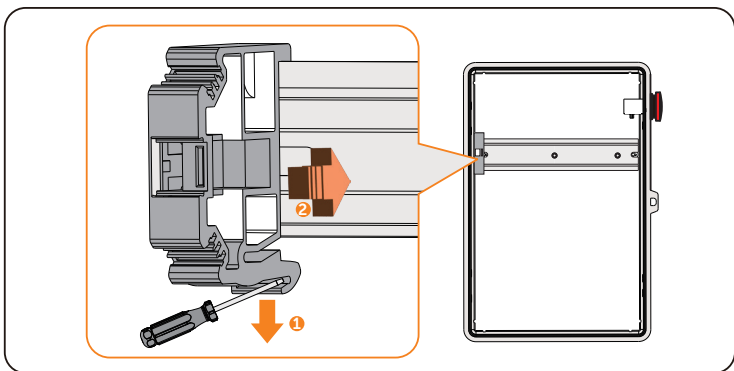

Figure 3-17 Fix clamp



- 2) Pull down the bottom latch of the power supply. Attach the power supply to the rail and push the latch back.

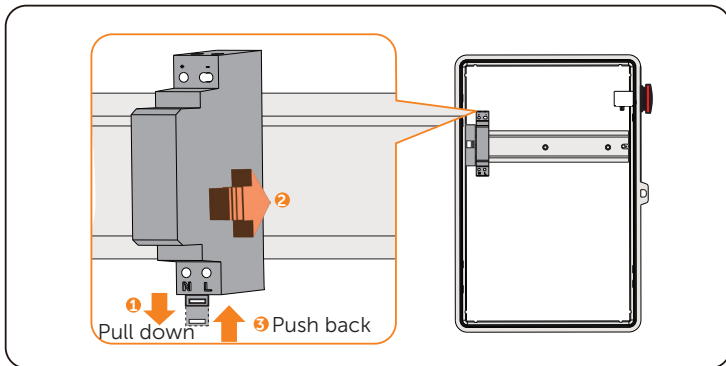

Figure 3-18 Fix power supply

- 3) Pull down the latch of transmitter. After fixing the transmitter to the rail, push the latch back. Install another clamp next to the transmitter.

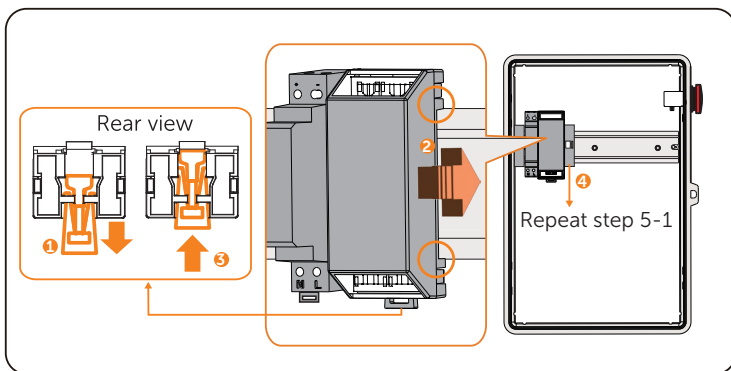

Figure 3-19 Fix transmitter and clamp

- 4) Assemble the module according to the *SolaX Pocket WiFi+LAN Series Installation Manual*, and then mount it on the Din rail. Insert the M4\*L16 screws into the holes on both sides of the pipe strap, then use a cross-screwdriver to fix the screws on the rail.

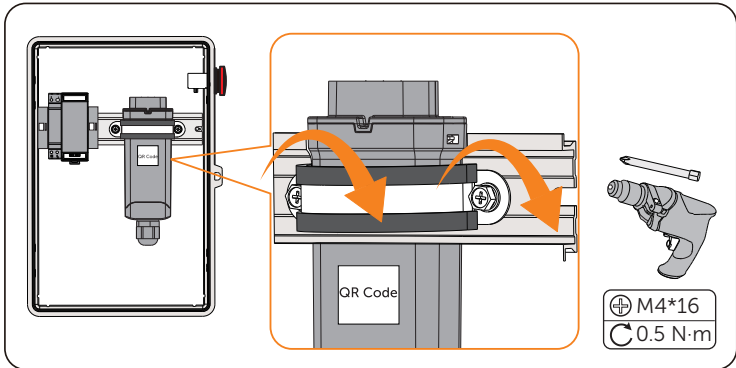

Figure 3-20 Fix monitoring dongle

**NOTICE!**

- Please display the QR code on the monitoring dongle for easy scanning.
- Make sure to tighten screws twice (or more): temporary tightening and final tightening.

- 5) Insert the cores into the bottom of the transmitter until you hear a "click". If there is only single core , connect Core 1 to PLC1 first.

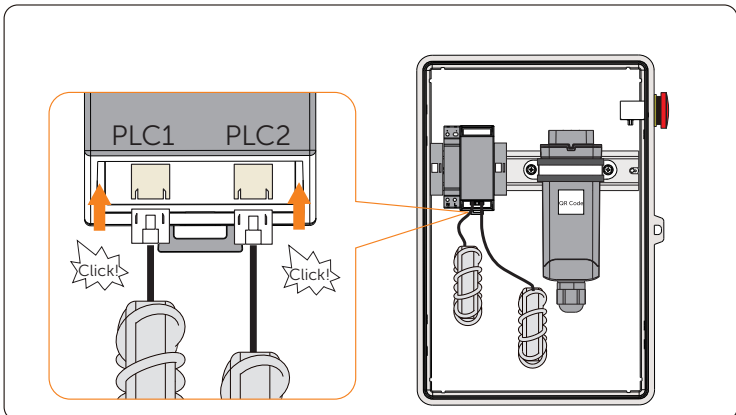

Figure 3-21 Insert the cores

- Step 6:** Connect the emergency stop switch wire to the power supply and fix it to the rail. Then secure the wires with a flat-head screwdriver.
- red/black wire — Power supply "+" / "-" port  
 plastic terminal — Transmitter "+12V-GND" port (Align the red wire with the "+12V" port and the black wire with the "GND" port.)

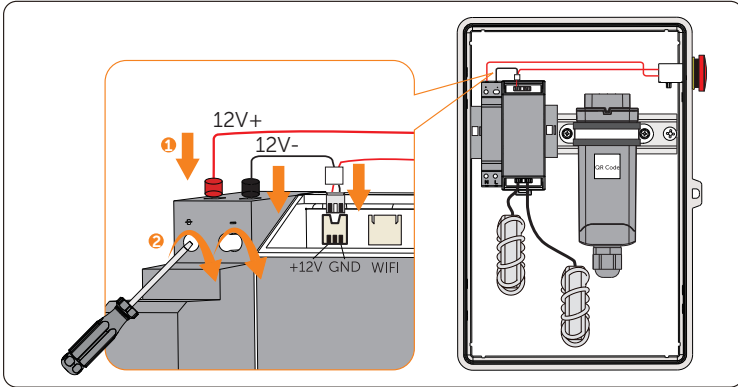

Figure 3-22 Connect emergency stop switch wire

- Step 7:** Use the signal cable to connect the transmitter's "Wi-Fi" port and the SolaX Pocket WiFi+LAN.

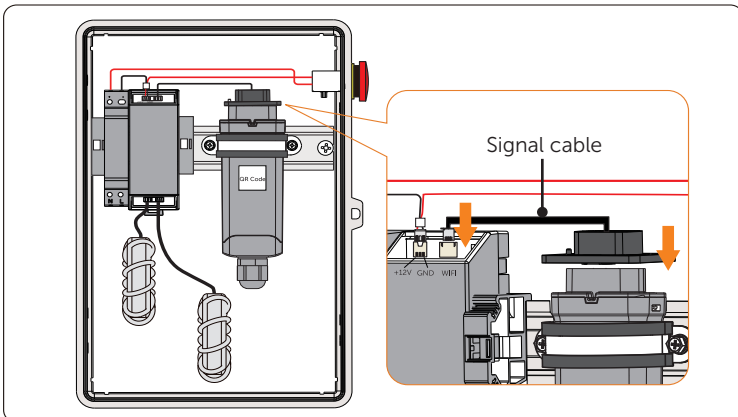

Figure 3-23 Connect transmitter and monitoring dongle

## Wall mounting

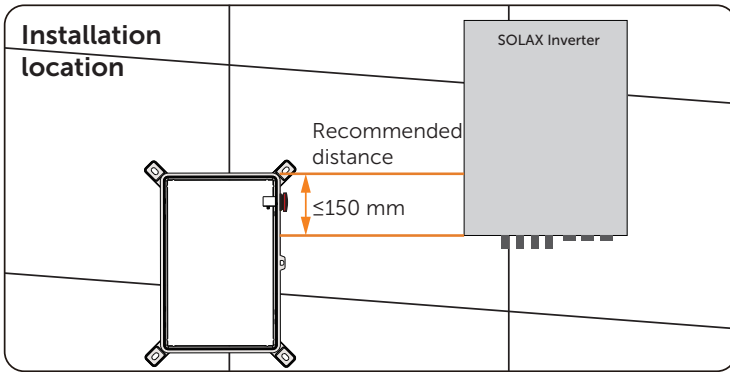

Figure 3-24 Recommended installation distance

**Step 8:** Lock the XRSD-Core Kit box.

Align the enclosure horizontally on the wall with spirit level: adjust the enclosure until the bubble stays in the middle.  
Mark the position of the drill holes.

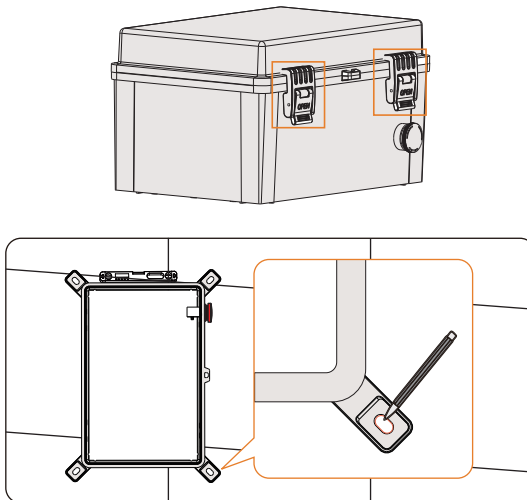

Figure 3-25 Mark the holes of XRSD-Core Kit box

**Step 9:** Set the enclosure aside and drill holes.(Drill bit:Ø10; Depth:60-80mm)  
Insert the expansion bolt into holes by using a rubber mallet.

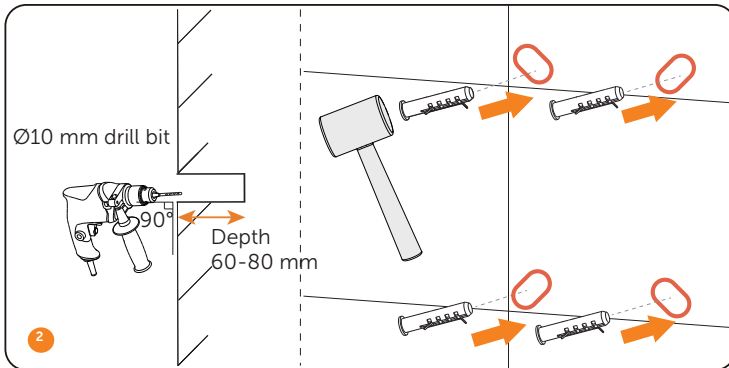

Figure 3-26 Drill the holes

**Step 10:** Use a torque wrench to secure the enclosure to the wall with expansion bolts.

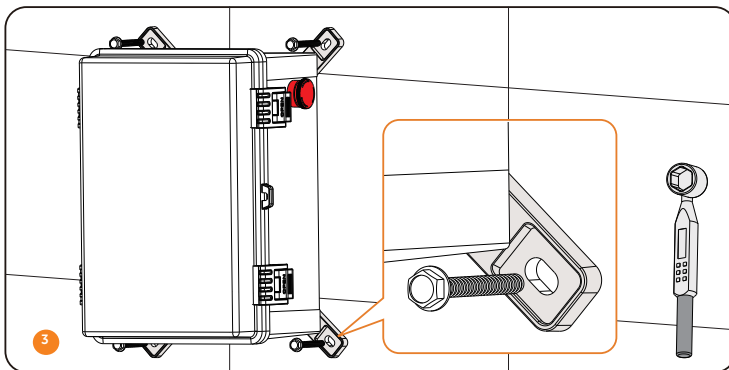
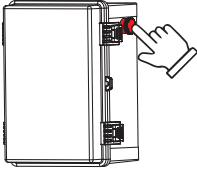

Figure 3-27 Secure the expansion bolts

## Wire connection



**⚠ DANGER!**

Press the emergency stop button to cut off the AC power before wire connection.

**Step 11:** Pull the PV cable through a corrugated pipe into the box.

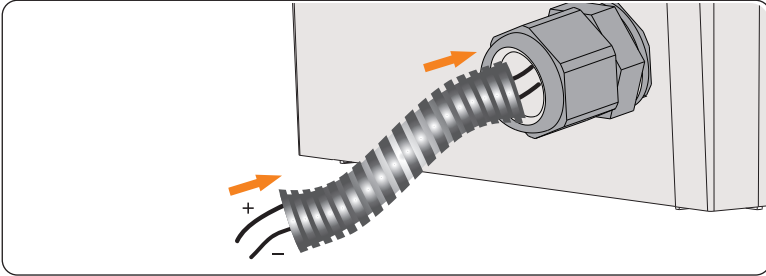

Figure 3-28 Pull the PV cable through corrugated pipe

**Step 12:** Connect wires to N,L port of power supply from grid or inverter.  
Pass the same positive PV cable(+) **or** the same negative PV cable(-)  
through cores. Then run the PV cables through the box to the inverter.

**NOTICE!**

For SolaX Energy storage inverter, connect AC wires from **EPS terminal**.

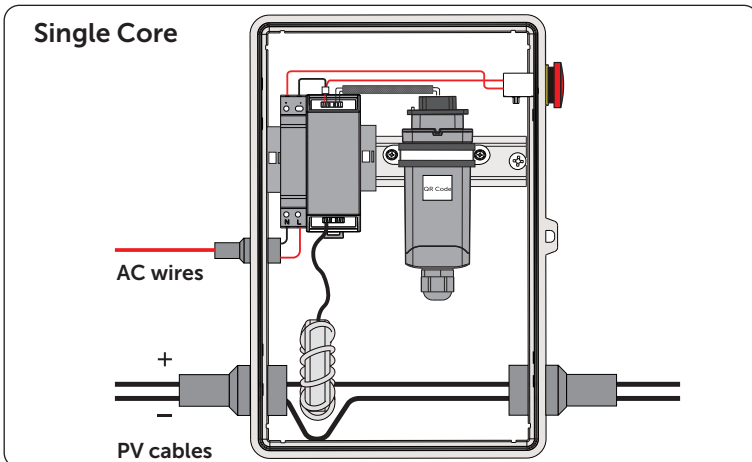

Figure 3-29 ingle Core-cable connect

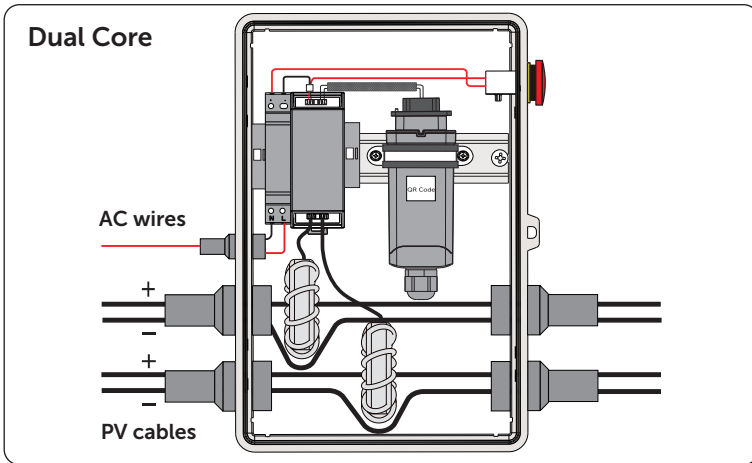

Figure 3-30 Dual cores-cable connect

**NOTICE!**

If the number of PV strings exceeds 10, do not pass PV cable (-) through the box, connect it to the inverter from outside the box.

**NOTICE!**

If you select the optional monitoring dongle and a LAN connection is used, pull another side of the network cable out of the box, crimp RJ45 connector and connect to router.

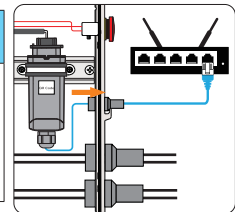

**Step 13:** Strip the 7mm insulation of the PV cables and insert the stripped cable into the PV pin contact. Crimp it with crimping tool for PV terminal.

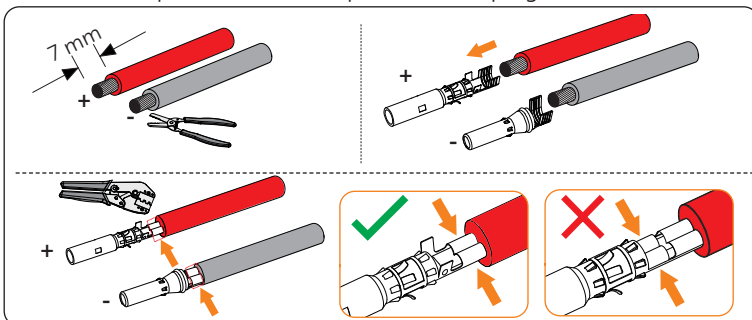

Figure 3-31 Stripping the PV cable and insert to PV pin contact

**Step 14:** Make the MC4 connector for PV cables.

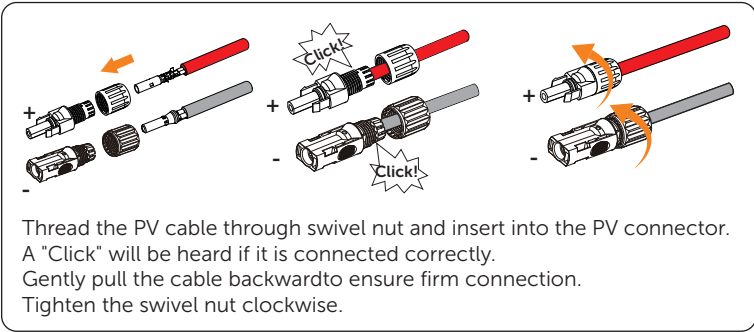

Figure 3-32 Making MC4 connectors

**CAUTION!**

Make sure the the PV cable and PV pin contact are of the same polarity.

**Step 15:** Connect the serially connected outputs of XRSD to the inverter with the assembled connectors until there is an audible "Click".

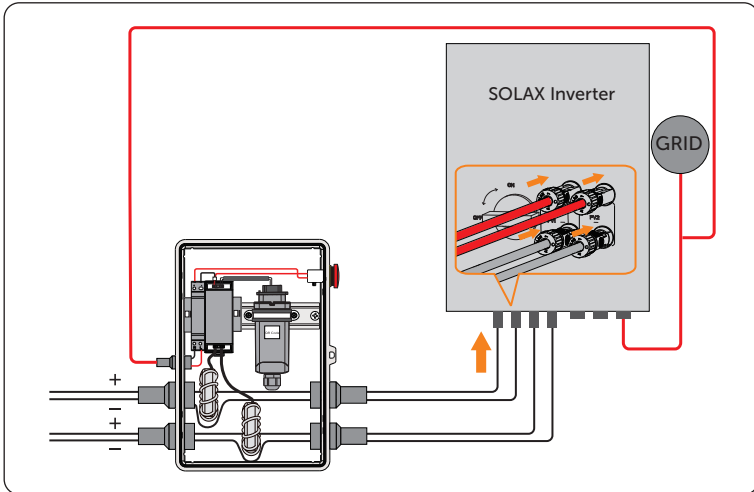

Figure 3-33 Connect outputs of XRSD to the inverter

**NOTICE!**

Max cable length from inverter(+) to inverter(-) : 200m



## Commissioning

**Step 1:** Release the emergency stop button to turn on the AC power.

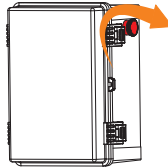

Figure 3-34 Twist emergency stop button

**Step 2:** Turn the DC switch of the inverter to ON position.

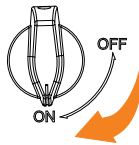
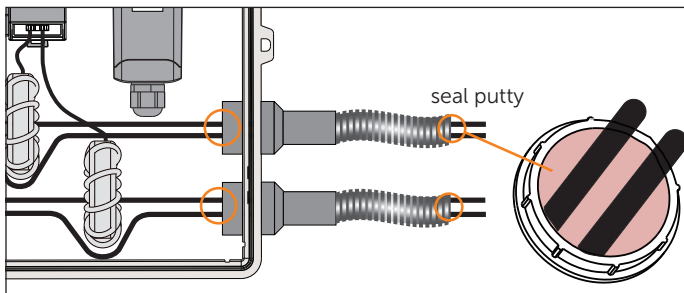

Figure 3-35 Turning on the DC switch

**Step 3:** After waiting for about 1 minute, please check the voltage of the series circuit displayed on the inverter. The voltage should be module open circuit voltage\* the number of modules.

### NOTICE!

After installing XRSD and XRSD-Core Kit, fill gaps around pipes both outside and inside with seal putty.



### 3.6 Conduit Drilling Guide

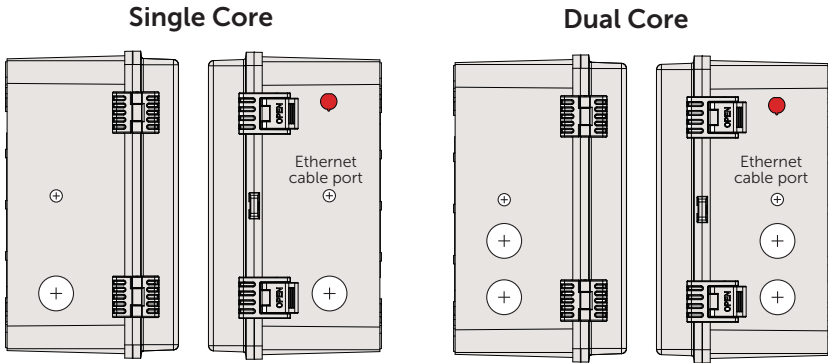

**NOTICE!**

Ethernet cable port is only required when the monitoring dongle (optional) is selected and a LAN connection is used.

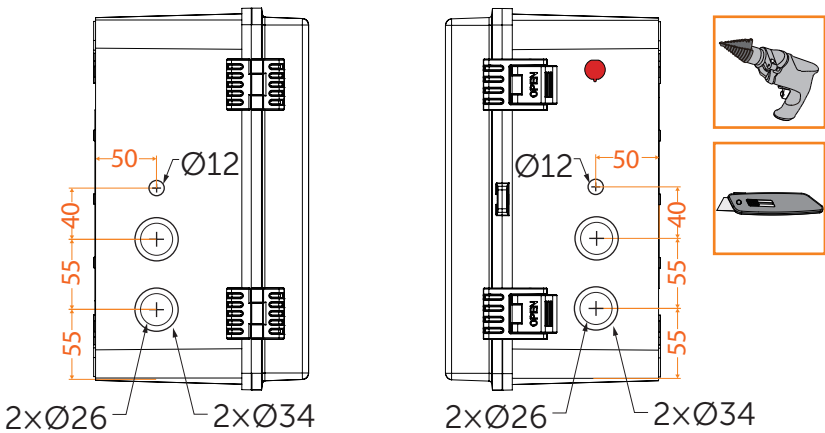

Figure 3-36 Drilling Guide for 1"and .75" Conduit

# 4 Remote monitoring

---

\* The following content applies to the XRSD-Core Kit with monitoring dongle.

SolaxCloud is an intelligent management platform for home energy, which integrates energy efficiency monitoring, device management, data security communication and other integrated capabilities.

The XRSD-Core Kit, equipped with Pocket WiFi+LAN, can upload operation data to the SolaX Cloud through a WiFi or LAN network connection. You can log in to your user account to view real-time monitoring data or historical data, and perform remote settings as needed.



The Pocket WiFi+LAN in XRSD-Core Kit and the module dongle on the SOLAX inverter have similar appearances. Do not mix them.

Operation flowchart:

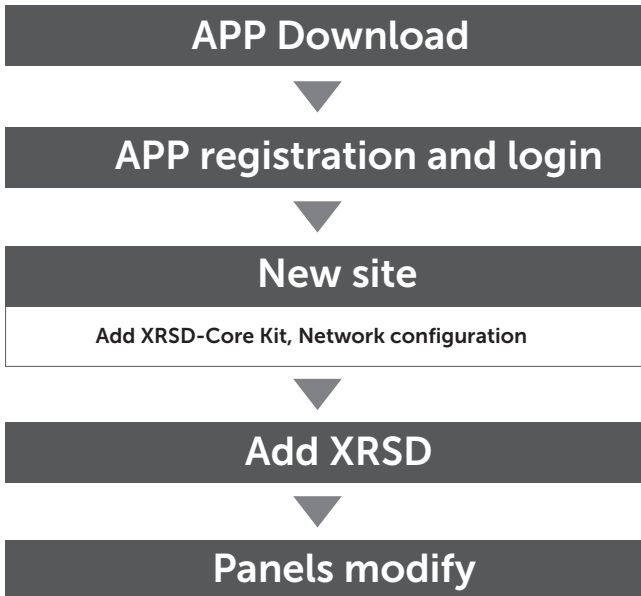

\* The instructions and screenshots in this manual are taken only as examples, which may be slightly different from the actual display.

### 4.1 Downloading and installing SolaX Cloud App

Select and scan the QR code below to download SolaX Cloud APP. You can also find the QR codes at the top left of the login page of [www.solaxcloud.com](http://www.solaxcloud.com). In addition, you can search with the key word SolaxCloud in Apple Store or Google Play to download it.



Figure 4-1 QR code

### 4.2 App Registration and Login

Run the App and touch **Sign up** at the bottom. Fill in your registration Email, verification code, and password to create an account. Log in the App after registration finished.

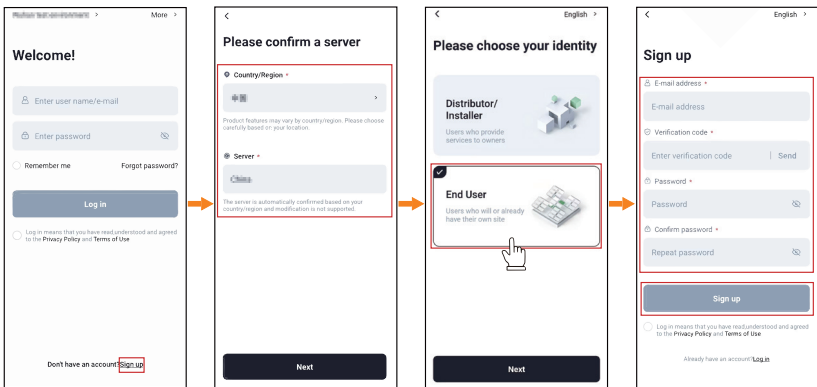

Figure 4-2 Create a new account and log in

## 4.3 Site creation and Wi-Fi configuration

### a. Creat Site

Tap **+** to create your site. Allow SolaxCloud to access your system location, fill in site name (self-defined), system size (For the system size, please check the information with the installer), choose the following settings according to actual situations. Tap **Next** to add device.

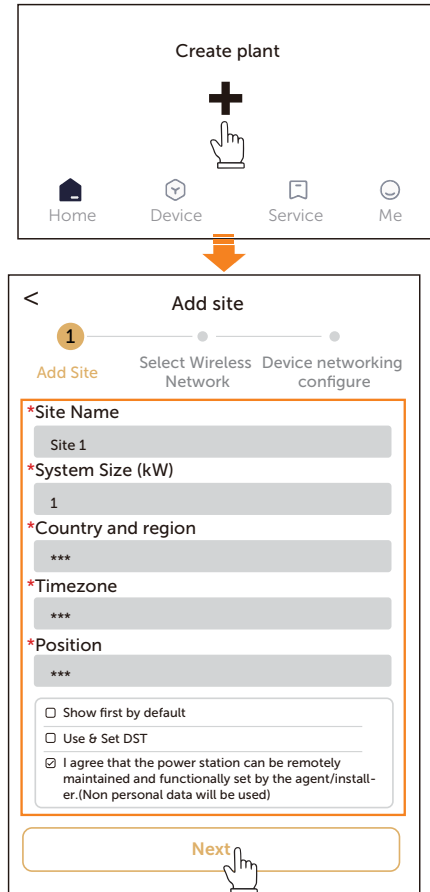

Figure 4-3 Creating the site

### NOTICE!

Select **Use&Set DST** if your country has summer time and winter time.

- b. Add XRS-D-Core Kit  
Scan or enter the QR code on Pocket WiFi+LAN, tap **Next**.

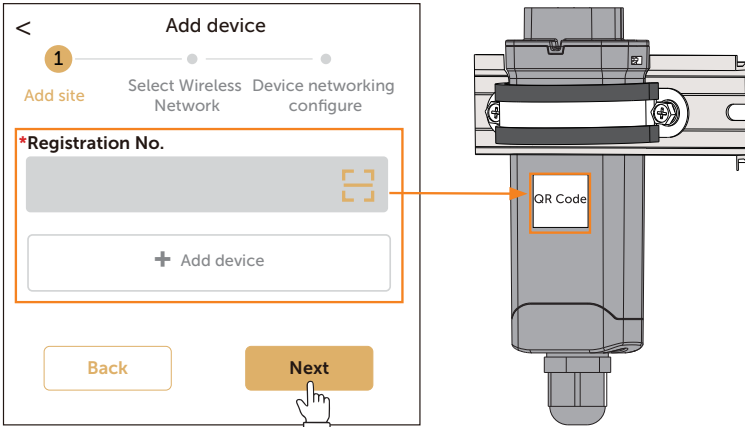

Figure 4-4 Add XRS-D Core Kit

- c. Connect via Wi-Fi  
Tap arrow to select your local network from the list. Enter the network password and tap **Next**. After configuration ended, tap **OK**.
  - \* If an Ethernet connection is used, skip this step.
  - \* DHCP is enabled by default to distribute IP address automatically.
  - \* 5GHz network is not supported.

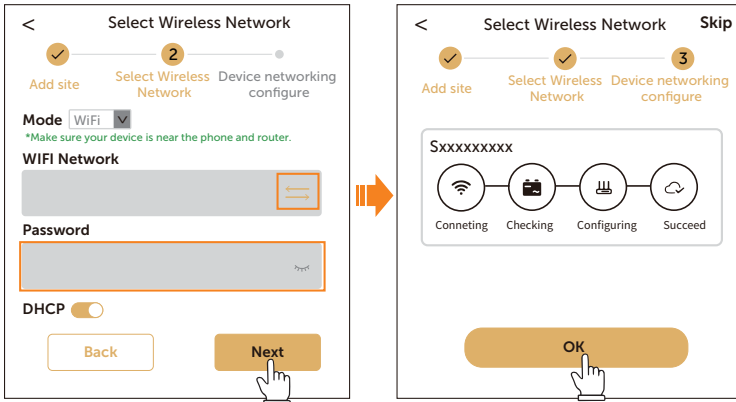
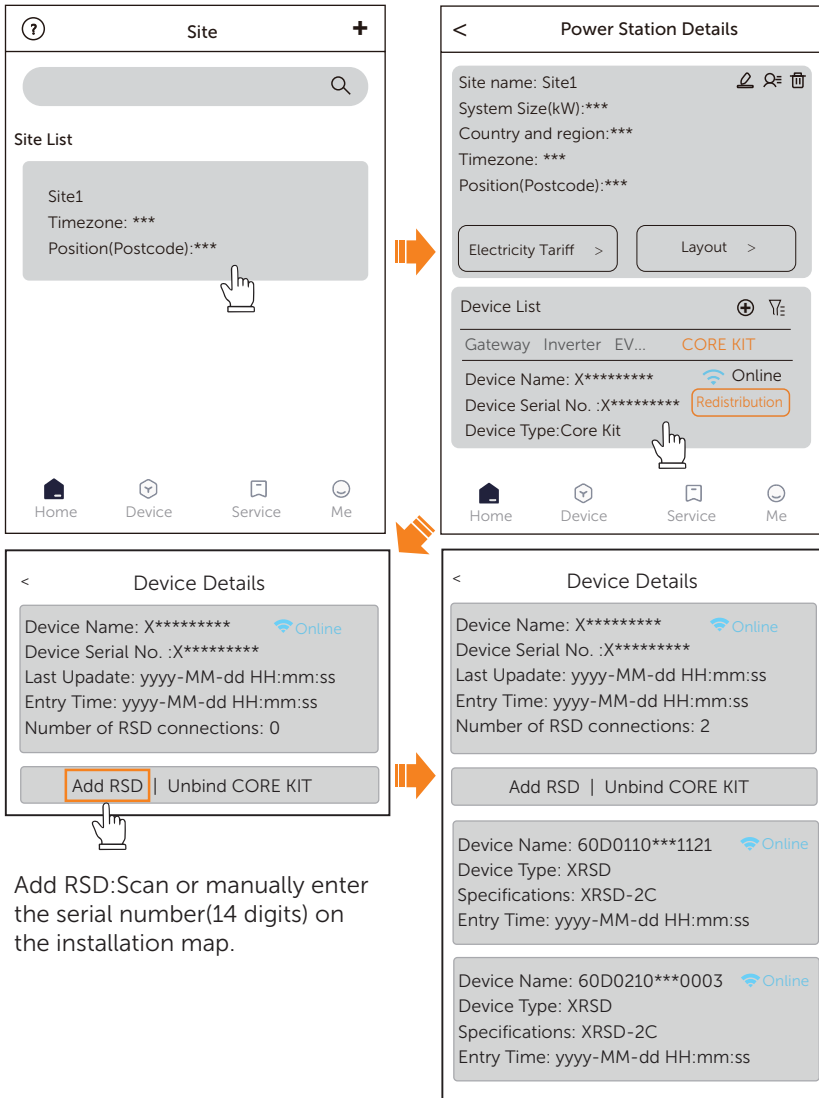

Figure 4-5 Wi-Fi configuration

## 4.4 Add XRSD

To view an existing site, select one of the systems in the list. To add XRSD, tap the added Core Kit > **Auto find | Add RSD**



Add RSD:Scan or manually enter the serial number(14 digits) on the installation map.

Figure 4-6 Add XRSD

Enter each XRSD page, you can see the device details and PV panel’s current, volatage, power, temperature.

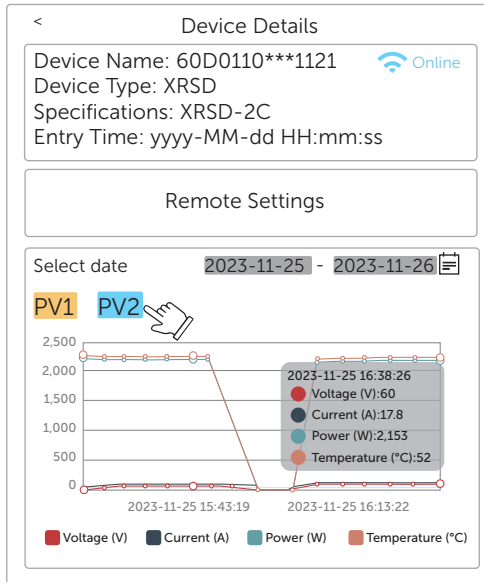

Figure 4-7 XRSD details

## Remote setting

Enter XRSD device details page and select **Remote Setting** to monitor PV panels. You can remotely shutdown XRSD and set the conditions for shutdown automatically (over temperature, over current, over voltage).

After setting, select **save**, and the screen will display **Setup successful**.

Basic Settings 60D0110***1121		Meaning	Options	Initial value
Rapid shutdown	▼	XRSD shutdown remotely	Disable/Enable	Disable
protection temperature	▼	XRSD automatic shut down conditions	range: -100 - 100	85
PV protection current	▼		range: 0 - 25.5	21.5
PV1 protection voltage	▼		range: 0 - 255	80
PV2 protection voltage	▼			

Figure 4-8 XRSD remote setting



## 4.5 Layout Settings

Place the modules according to the physical layout: an exact map will help you understand the position of XRS-D and each PV panel's power. In addition, this will facilitate future maintenance work.

### a. Set PV array rules

- 1) Enter power station page, select **Layout>Edit now>Array rules**.

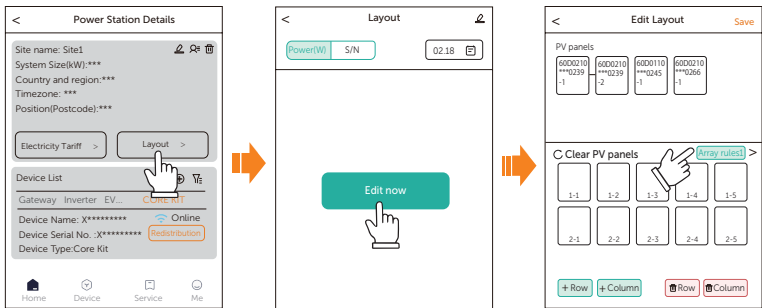

Figure 4-9 Edit Layout page

- 2) There are 3 display rules by default. Select one and set layout method (Vertical on Horizontal), Azimuth ( $0^{\circ}$ ~ $360^{\circ}$ ), Tilt ( $0^{\circ}$ ~ $90^{\circ}$ ), tap **Save**.
- 3) Mared the select array rule, tap **Save**.

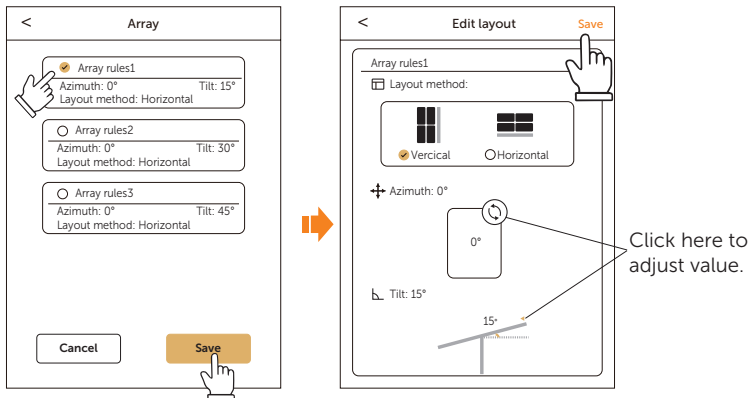

Figure 4-10 Set array rules

b. Edit layout

- 1) Enter Edit layout page, select **C Clear PV panels**
- 2) The bottom coner modify the PV layout.  
You can tap **+ Row** **+ Column** to add row/column,  
tap **Row** **Column** to delete row/column.
- 3) To place the XRSD  
Tap to select apper XRSD, tap the specific potion of PV panel.

To delete a XRSD

Tap twice to select a PV panel. Or tap the above XRSD.

- 4) After layout setting finished, Tap **Save** in the upper right coner. **Saved successfully** will pop up.

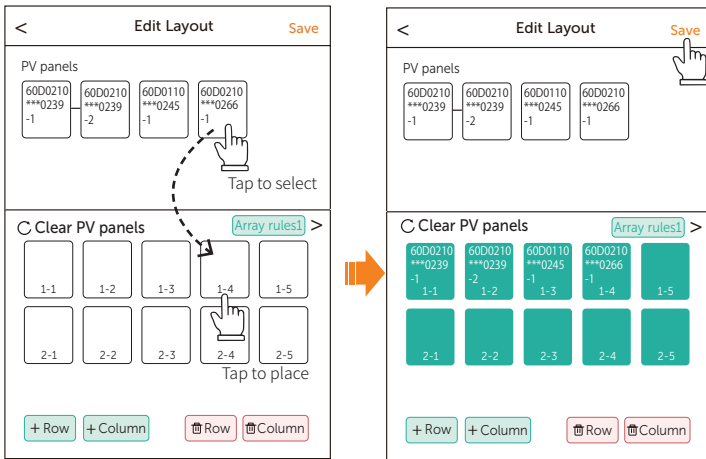

Figure 4-11 place XRSD

- c. Click **<** in the upper left corner to return to the layout interface.

Tap **Power(W)** **S/N** to check serials number of XRSD.

Tap **Power(W)** **S/N** to check the total PV power of the current day or history.

Select a PV to check the PV details, which include:

<b>S/N</b>	the serials number
<b>port</b>	1 represent XRSD-1C,2 represent XRSD-2C
<b>Device type</b>	XRSD
<b>Connection status</b>	Network status Normal/Exception
<b>Alarm status</b>	Normal/Exception(i.e over current)

## Data Graphics

Current, voltage, and power values at now  
Current, voltage, and power trend charts so far

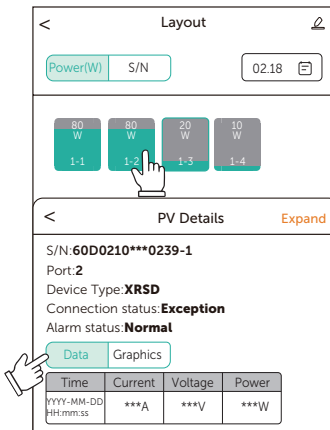

Hint:

The PV array rules (horizontal/vertical, tilt angle) will affect the display of PV here. The legend represents that the PV display is **vertical** and the tilt angle is **0**.

Hint:

Tap Expand to confirm more data.

Figure 4-12 PV Details

**Total power** At the bottom is the dynamic power curve of the day.

Drag the yellow line left or right to quickly locate any point in time.

Tap (forward) or (backward) to fine-tune the time.

Indicates starting play or pause from the positioned time point.

Indicates that it will start playing at 0 o'clock that day.

You can also click on the date above to select a historical date.

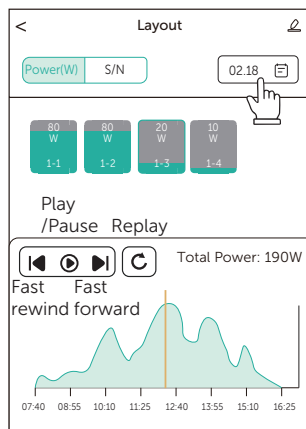

Tap to select a different date.

Figure 4-13 Dynamic power curve

# 5 Rapid Shutdown methods

XRSD can be shutdown automatically or manually. For modify the automatic shutdown setting value, please refer to [Remote setting \(P38\)](#).

## 5.1 Automatic shutdown

Automatic shutdown will occur if any of the following conditions are met:

- Over temperature  
When the temperature sensor on the XRSD detects ambient temperature is over the set value (Default: **85°C**)
- Over voltage  
When a single PV module voltage exceeds the set value (Default: **80V**)
- Over current  
When a single PV module current exceeds the set value (Default: **20A**)

## 5.2 Manual shutdown

### AC Supply Cut-Off

Shut down solar panel by disconnecting the external AC supply.

### Activate an external initiator

Activate an external initiator when there is an emergency, then the PV system will enter module-level rapid shutdown within the time specified by the safety regulations.

The Emergency Switch can be conveniently located at ground level for easy access, and multiple switches can be installed in different multi-level building zones.

### APP/WEB Remote Control

you can operate individual panel shutdown from a long distance through the SolaX Cloud.

Enter XRSD page, tap **Remote setting** > **Rapid Shutdown** > **Disable** > **save**.

(Disable: Enter rapid shutdown mode  
Enable: Exit rapid shutdown mode)

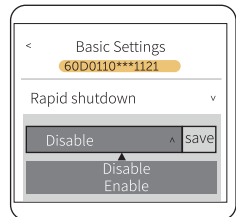
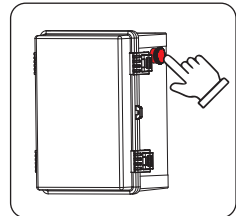
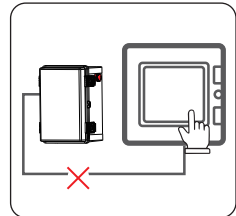

# 6 Technical Data

- XRSD

Model	XRSD-1C	XRSD-2C
<b>Electrical Data</b>		
Input voltage range	8-80V	8-80V / 8-80V
Output voltage range	8-80V	16-160V
Max. PV input current	20A	20A
Max. short circuit current	26A	26A
Recommended fuse rating	30A	30A
Maximum system voltage	1500V	1500V
<b>Mechanical</b>		
Dimensions(W x D x H) (Without cables and connectors)	130 x 21 x 36mm	135 x 20 x 59mm
Weight(Including Cables)	400g	720g
Input cable length	0.2m	0.45m
Output cable length	1.2m	2.4m
Input / Output connectors	MC4 (standard)	
Communication type	PLC	
<b>Environment limit</b>		
Altitude	0-3000m	
Pollution degree	3	
Protection class	IP68	
Operating temperature range	-40°C to +85°C	
Humidity	4% - 100%	
Over voltage category	II	
<b>Compliance</b>		
Safety	IEC/EN62109-1, EN IEC 61000-6-1/2/3/4	

Unit: mm

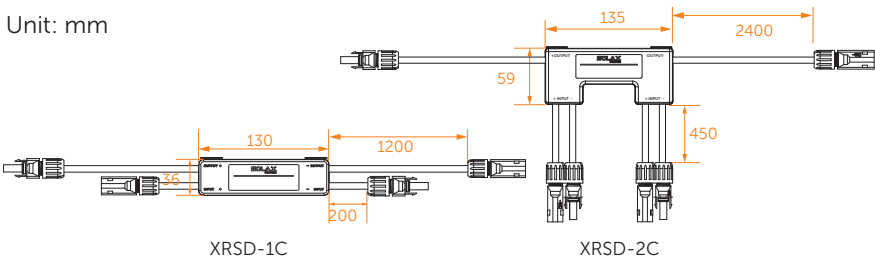

## Technical Data

- XRSD-Core Kit



Model	XRSD-Core Kit
<b>Electrical Data</b>	
Power Supply Input Voltage	85-264Vac
Transmitter Input Voltage	12Vdc (±2%)
Transmitter Input Current	1A
<b>Core</b>	
Max. Number of Configure Core	2
Max. Current per Core	150A
Max. String Voltage	1500Vdc
Diameter	~31 (inner) /52mm (outer)
Max. Number of Strings per Core*	11
<b>Mechanical</b>	
Dimensions(W x D x H)	200 x 170 x 300mm
<b>Environment limit</b>	
Altitude	0-3000m
Pollution degree	3
Protection class	IP65
Operating temperature range	-40°C to +75°C
Humidity	4 - 100%
Over voltage category	III
<b>Compliance</b>	
Safety	IEC/EN62109-1, EN IEC 61000-6-1/2/3/4

\* This data refers to a cable diameter of Ø6 mm.If cable diameter is more than Ø6 mm,Strings Per Core will be reduced. Extra precaution must be taken to avoid exceeding the permissible current limit.

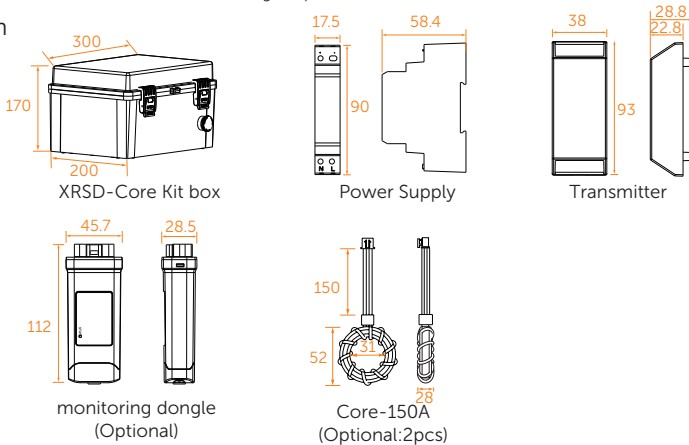
Unit: mm



# 7 Appendix

 <b>XRSD Installation Map</b>																	
Measure N for North 		Based Upon: Aerial Photo: Date: Sheet of _____		Customer Information:							XRSD Case File Number:						
COLUMN	ROW	1	2	3	4	5	6	7	8	9	10	11	12	13	14	15	16
A																	
B																	
C																	
D																	





# Contact Information



## UNITED KINGDOM

---

- Unit C-D Riversdale House, Riversdale Road, Atherstone, CV9 1FA
- +44 (0) 2476 586 998
- [service.uk@solaxpower.com](mailto:service.uk@solaxpower.com)



## TURKEY

---

- Fevzi Çakmak mah. aslım cd. no 88 A Karatay / Konya / Türkiye
- [service.tr@solaxpower.com](mailto:service.tr@solaxpower.com)



## USA

---

- 3780 Kilroy Airport Way, Suite 200, Long Beach, CA, US 90806
- +1 (408) 690 9464
- [info@solaxpower.com](mailto:info@solaxpower.com)



## POLAND

---

- WARSAW AL. JANA P. II 27. POST
- +48 662 430 292
- [service.pl@solaxpower.com](mailto:service.pl@solaxpower.com)



## ITALY

---

- +39 011 19800998
- [support@solaxpower.it](mailto:support@solaxpower.it)



## PAKISTAN

---

- [service.pk@solaxpower.com](mailto:service.pk@solaxpower.com)



## AUSTRALIA

---

- 21 Nicholas Dr, Dandenong South VIC 3175
- +61 1300 476 529
- [service@solaxpower.com.au](mailto:service@solaxpower.com.au)



## GERMANY

---

- Am Tullnaupark 8, 90402 Nürnberg, Germany
- +49 (0) 6142 4091 664
- [service.eu@solaxpower.com](mailto:service.eu@solaxpower.com)
- [service.dach@solaxpower.com](mailto:service.dach@solaxpower.com)



## NETHERLANDS

---

- Twekkeler-Es 15 7547 ST Enschede
- +31 (0) 8527 37932
- [service.eu@solaxpower.com](mailto:service.eu@solaxpower.com)
- [service.bnl@solaxpower.com](mailto:service.bnl@solaxpower.com)



## SPAIN

---

- +34 9373 79607
- [tecnico@solaxpower.com](mailto:tecnico@solaxpower.com)



## BRAZIL

---

- +55 (34) 9667 0319
- [info@solaxpower.com](mailto:info@solaxpower.com)



## SOUTH AFRICA

---

- [service.za@solaxpower.com](mailto:service.za@solaxpower.com)





## **SolaX Power Network Technology (Zhejiang) Co., Ltd.**

Add.: No. 278, Shizhu Road, Chengnan Sub-district, Tonglu County,  
Hangzhou, Zhejiang, China  
E-mail: [info@solaxpower.com](mailto:info@solaxpower.com)

