



# Liquid Cooling Energy Storage System

**TRENE-P79B261L-E/TRENE-P100B261L-E  
TRENE-P124B261L-E/TRENE-P125B261L-E**

## Installation Manual

Version 1.0

[www.solaxpower.com](http://www.solaxpower.com)



eManual in the QR code or at  
<http://kb.solaxpower.com/>



# Table of Contents

---

Safety.....	1
Preparation before Installation .....	9
Mechanical Installation.....	19
Electric Connection .....	23
System Commissioning.....	28
LED Indicators .....	32
System Decommissioning.....	35
Technical Data.....	38



## Safety

















### General Notice

1. Contents may be periodically updated or revised. SolaX reserves the right to make improvements or changes in the product(s) and the program(s) described in this manual without the prior notice.
2. The installation, maintenance and grid-related setting can only be performed by qualified personnel who:
  - Are licensed and/or satisfy state and local jurisdiction regulations;
  - Have good knowledge of this manual and other related documents.
3. Before installing the device, carefully read, fully understand and strictly follow the detailed instruction of the user manual and other related regulations. SolaX shall not be liable for any consequences caused by the violation of the storage, transportation, installation, and operation regulations specified in this document and the user manual.
4. Use insulated tools when installing the device. Individual protective tools must be worn during installation, electrical connection and maintenance.
5. Please visit the website [www.solaxpower.com](http://www.solaxpower.com) of SolaX for more information.

### Safety Instruction

For safety reasons, installers are responsible for familiarizing themselves with the contents of the Manual and all warnings before performing installation.

### Descriptions of Labels

	CE mark of conformity		TUV certification
	RCM mark of conformity		Grounding point
	Additional grounding point		Caution, risk of danger
	The battery module may explode.		Caution, risk of electric shock
	Caution, hot surface		Do not operate this system until it is isolated from mains.
	Read the enclosed documentations.		Keep the system away from children.
	Keep the system away from open flames or ignition systems.		Do not dispose of the device module together with household waste.
	Danger of high voltage. Do not touch live parts for 15 minutes after disconnection from the power sources.		
			The system must be disposed of at a proper facility for environmentally-safe recycling.

 **DANGER!**

- According to the local laws and regulations related to high-altitude work, operators must wear PPE, e.g., a helmet, safety belt, or waist harness, when they work at heights, while the other end of the harness must connect to a secure structure to prevent fall incidents.

 **DANGER!**

- Do not connect the positive and negative poles of a battery together. Otherwise, it may be short-circuited. This will result in an excessive flow of current and large quantities of energy for a short time, and then will cause battery leakage, smoke, the emission of flammable gases, thermal runaway, fire, or even an explosion. Therefore, the battery must be powered off before maintenance.
- If a battery is overheated, it will cause leakage, smoke, release of flammable gases, thermal runaway, fire, or even an explosion. Therefore, please ensure that the installation site shall be well ventilated and kept away from high temperatures.
- Do not dismantle, change, shake, drop, crush, impact, cut, penetrate with a sharp object, or any other ways to damage the battery. Otherwise, it may cause leakage, smoke, emission of flammable gases, thermal runaway, fire, or even an explosion.
- Do not mix different types or makes of the battery. Otherwise, it may cause leakage or rupture, resulting in personal injury or property damage.
- The battery electrolyte is toxic and volatile. Never get in contact with the leaked liquids or inhale gases in the case of the battery leakage or odor, and contact professionals immediately. The professional must wear PPE (including but not limited to safety glasses, safety gloves, gas masks, and protective clothing) before powering off the device, and then contact our company at once after removing the damaged battery.
- Normally, the battery will not release any gases. However, in the following situations: burnt, needle-pricked, squeezed, struck by lightning, overcharged, or subject to other adverse conditions that may cause battery thermal runaway, the battery may be damaged or an abnormal chemical reaction may occur inside the battery, resulting in electrolyte leakage or production of gases. If the battery needs to exhaust flammable gas, safe emission measures must be taken to prevent fire and device corrosion.
- Do not use damaged batteries, and ensure that the installation site must be well ventilated.

 **DANGER!**

- Only operate the PCS if it is in a technically faultless condition. Operating a faulty PCS may lead to electric shock or fire.
- Do not attempt to open the enclosure without authorization from SolaX. Unauthorized opening of the enclosure will void the warranty and can result in lethal danger or serious injury due to electric shock.
- Make sure that the PCS is reliably grounded before any operation to prevent the risk of electric shock causing lethal danger or serious injury.
- Only qualified personnel can perform the installation, wiring, maintenance of the PCS by following this document and the related regulations.

 **DANGER!**

- Please make sure that the unit is free from any damage before the electrical connection.
- Do not modify, change, or dismantle the device, do not change the power-on and power-off sequences and the installation procedure written in the document, and please properly and correctly operate it.
- Do not power on the device during installation. Otherwise, it may cause a fire, personal injury, or device damage.
- Must remove earrings, rings, bracelets, watches, and any other metal jewelry before operation, to avoid electrical shock, burns, or even death.
- During operation, special insulated tools must be used to avoid electric shock or short circuit failure. The insulated tools' voltage ratings must exceed the system voltage ratings. Please refer to "Technical Data" for system information.

 **WARNING!**

- Please prepare tools that meet the requirements before installation, and check the number of tools after installation, to avoid leaving them inside the equipment.
- Please ensure that the cabinet has been thoroughly secured before operating it. Otherwise, it may cause personal injury or equipment damage due to tilting or collapsing the cabinet.
- Please ensure that the cabinet's vents and cooling system are working properly when it is running. If the vents are blocked, it will lead to overheating, and even equipment damage or fire hazard.
- Please ensure that the cabinet's vents and cooling system are kept away from heat sources.
- Do not drill holes in the device to avoid equipment failure.
- If the circumstances that may cause personal injury or equipment failure occur, such as, fluid flowing into the equipment, stop operation and power off immediately. Otherwise, it may cause a short circuit or damage.
- Do not open the cabinet doors on a rainy or high humid day ( $\geq 80\%$  humidity). If the doors have to be opened on such days, please take proper protective measures.

 **WARNING!**

- Please read the document carefully before installation, operation and maintenance.
- Must arrange fire-fighting equipment in advance according to the local laws, regulations, and standards while installing and commissioning the device.
- Please check that there is no damage to the outer packaging before and after unpacking, and in the process of storage and transportation. The battery shall be correctly placed or stacked in accordance with the requirements stipulated on the labels to prevent damaging or scrapping the battery resulting from crushing or falling.
- Must tighten screws securing cables and on the copper bars according to the torque information specified in the document, and check whether they are tightened periodically. For instance, whether there is any rust, corrosion, or any other foreign object on it, and then clean it up if any. Because the loose screw connections may result in excessive voltage drops and large currents, leading to generating a lot of heat and burning the battery.

 **WARNING!**

- The battery should be charged in time after discharge, to prevent battery damage due to overdischarge. If a battery pack is stored for a long time, please periodically recharge it to protect it from damage according to the storage requirements specified in the document.
- Please charge the battery within the specific temperature range because the low temperature may result in a short circuit. Hence, do not charge it when the temperature is below the low limit of the operating temperature.
- Do not use the battery when you find a bulge, or dents on the battery housing, and contact the installer or professional maintenance personnel to dismantle and replace it. The damaged battery must be kept away from other devices and flammable and explosive articles, and do not contact it except for professionals.
- Before operation, ensure that there are no irritating or burning smells around the battery.
- Do not weld or grind near a battery. Because electric sparks or arcs may cause fires.
- Do not step, lead, stand, or set on the battery.

 **WARNING!**

- Operators must wear PPE while installation and maintenance of the device.
- During operation, avoid touching any parts of the PCS other than the LED panel.
- Never connect or disconnect the AC and DC connector while the PCS is running.
- Prior to conducting any maintenance, turn off the AC and DC power and disconnect them from the PCS. Wait for 15 minutes to fully discharge the energy.
- Avoid touching the PCS while it is running, as it becomes hot during operation and may cause personal injuries.

 **WARNING!**

- Please wear PPE, such as, protective clothing, insulating shoes, goggles, safety helmets, insulating gloves, etc., when conducting electrical wiring.
- Do not touch the power supply equipment directly, or through conductors or damp objects.
- Do not touch the parts of the equipment of which warning signs are attached, to avoid personal injury or device damage.

 **WARNING!**

- When the liquid cooling unit is running, please do not touch the internal components of the unit with your hands at will to avoid electric shock or injury from the fan blades.



 CAUTION!

- Do not use a straight ladder. When electrical work is involved, a wooden ladder or an insulated ladder shall be used.
- The equipment shall not be used to provide a backup power source in the following circumstances:
  - a. Equipment related to life;
  - b. Sensitive precision instruments;
  - c. Home appliances will be faulty in the case of a power failure during operation.
- Do not power on the equipment until it has been installed and confirmed by professionals.
- In the event of a fire, evacuate immediately and call the local fire services.

 CAUTION!

**Safety precautions for liquid cooling unit usage:**

- The waste is hazardous. Please properly handle it, and avoid contact of the waste with soil or drainage systems.
- Coolant may cause irritation to eyes, skin, and throat. When handling, wear PPE and use only authorized tools.
- Heating the liquid cooling unit in an empty container may cause an explosion.

 CAUTION!

- If severe vibration or abnormal sound occurs during running or debugging of the unit, please stop all operations and immediately cut off the circuit switch for inspection.
- Do not allow liquids such as water to enter the terminal area of the device during installation and maintenance.
- Only when all the circuit switches are turned off and the internal control board no longer flashes the signal light, can you operate the device circuit and electronic devices, and you must wear anti-static gloves.
- The waste is hazardous. Please properly handle it, and avoid contact of the waste with soil or drainage systems.
- Coolant may cause irritation to eyes, skin, and throat. When handling, wear PPE and use only authorized tools.
- Do not heat the liquid cooling unit in an empty container since it may cause an explosion.

NOTICE!

- The signs and messages on the labels and nameplates attached to the device need to be visible and clear.

## NOTICE!

### Transportation requirements for battery:

- Relevant qualifications for the transport of dangerous goods must be obtained by the forwarding agent engaged in such businesses, and they must strictly abide by the local regulations for the transport of dangerous goods.
- Please check the battery before transportation. If a battery leaks, smells, or is damaged, do refuse to transport it.
- Please handle gently in the process of loading and unloading, transportation, and moving a battery to prevent bumping, and take effective moisture-proof measures to prevent personal injuries and battery damage.
- Unless otherwise specified, do not transport the batteries, which are classified as dangerous goods, together with food, medicine, or other additives on the same means of transport.

**If the battery leaks electrolyte or any other chemical materials, the electrolyte leakage can lead to toxic gases. Therefore, do not contact with them at all times. In case of accidentally coming into contact with them, please do as follows:**

- In case of inhalation: Leave the contaminated area immediately, and seek medical attention at once;
- In case of contact with eyes: Rinse eyes with running water for at least 15 minutes, and seek medical attention;
- In case of contact with skin: Wash the contact area thoroughly with soap, and seek medical attention;
- In case of ingestion: Induce vomiting, and seek medical attention.

**If a fire breaks out where the battery is installed, please do as follows:**

- In case a battery is charging when the fire breaks out, provided it is safe to do so, press the emergency stop button and unplug the power cable;
- In case a battery is not on fire yet, use a water-based fire extinguisher or a carbon dioxide extinguisher to extinguish the fire;
- In case a battery catches fire, do not try to put it out, and evacuate immediately;
- A battery may catch fire when it is heated above 150°C/302°F. If the battery catches fire, please evacuate immediately since it will generate noxious and poisonous gases.

### Recovery of damaged or wasted battery:

- Dispose of the damaged or wasted batteries according to local laws and regulations instead of placing them in the household trash or curbside recycling bins. Otherwise, it may cause environmental pollution or explosions.
- Ensure that the damaged or wasted batteries are not exposed to the following situations: high temperatures, high humidity, direct sunlight, or corrosive environments.
- Contact a battery recycling company to scrap the battery, which leaks electrolytes, or is damaged or expired.
- Please take protective steps to prevent battery short circuits before moving batteries.
- Please keep away from flammable material storage areas, residential areas, and other population centers when transporting and storing the damaged battery.

### NOTICE!

- The PCS has an integrated Residual Current Monitoring Unit (RCMU). If an external Residual Current Device (RCD) is required by local regulations, verify the type of RCD required. It is recommended to use a Type-A RCD with a rating of 300 mA unless a lower value is required by the specific local electric codes. When required by local regulations, the use of an RCD type B is permitted.

### NOTICE!

- Only connect the PCS to the grid with the permission of the local utility grid company.

### NOTICE!

- Please operate according to the safety code for power station.
- Before installation, it is necessary to set up temporary safety fences or warning lines and hang warning signs in the operation area, to prohibit non-staff from entering here.
- Please make sure that the equipment and its associated switches are off before connecting and disconnecting power cables.
- Please check whether the protective housing and insulating sleeve for an electrical component have been installed correctly after finishing installation, to avoid electric shock.
- Must turn off the output switch of the power supply equipment when maintaining its electrical terminal device and power distribution device.
- If the device is required to be powered off during troubleshooting and diagnosis, please do as the following procedure: power off > electricity testing > connecting grounding cable > hanging warning signs and setting up guardrails.
- Must hang up "Do Not Switch On" warning signs on the relevant switches or circuit breakers before completing maintenance, to prevent power connection. Do not switch on before the fault is solved.
- Do not use water, alcohol, oil, or other solvents when cleaning electrical components inside and outside the device.

### NOTICE!

- While injecting the liquid, if the injection process is interrupted manually, restart the process from the beginning when resuming.
- During injection, ensure that the hose in the coolant collection tank is fully submerged and maintains proper coolant flow.
- After completing injection and drainage, thoroughly flush the hoses of the inject machine to remove residual coolant.
- Use a coolant collection tank with a capacity of 20 liters or more, and keep it clean, dry and free from contaminants.

## NOTICE!

If the coolant leaks, please avoid contact with it at all times. In case of accidentally coming into contact with it, please do as follows:

- In case of contact with eyes: Rinse eyes with running water for at least 15 minutes, and seek medical attention;
- In case of contact with skin: Wash the contact area thoroughly with soap, and seek medical attention.

## NOTICE!

### Grounding Requirements:

- The device's grounding impedance shall meet the requirements of local electrical safety standards.
- The equipment shall be permanently connected to a grounding wire within the building's electrical system. Please check whether the device is reliably grounded before operation. The grounding cable should be removed last while dismantling and maintaining the device.
- Do not start the device if it is not fitted with a grounding conductor.
- All acts against the grounding conductor are prohibited.
- If the device is equipped with a three-pronged socket, make sure that the ground prong is reliably grounded.
- For the device that may generate large contact currents, please make sure that the grounding terminal on the housing has been grounded before powering on, to avoid electric shock.

### Cable Requirements:

- When deciding the wire diameter, and connecting or wiring cables, follow the local laws, regulations, and codes to ensure safety.
- When external conditions (e.g., placement method, ambient temperature, etc.) change, the cable type must be verified according to IEC-60364-5-52 or local laws, regulations and standards. For instance, whether the cable's current-carrying capacity meets the requirements.
- Before connecting power cables, please make sure that the cable labels are correctly labelled and the cable terminals are well insulated.
- Do not loop and twist cables while conducting electrical wiring. If the length of the power cable is not enough, please replace it instead of joining or welding. Ensure that all the cables of the correct type and size are fully connected and well insulated, and the edges of cable slots and crossing holes are smooth.
- It is recommended to bundle similar cables with cable ties, to ensure that the inside of the device is neat and tidy and to avoid cable jacket damage.
- Please use fireproof mud to seal the threading openings immediately after finishing wiring, to avoid the entry of water vapour or small animals.
- Cables should be kept away from heaters or other heat sources, because a high temperature environment may result in aging and damage to cable insulation.

## Preparation before Installation

### Packing List

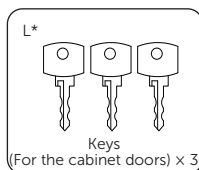
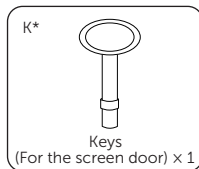
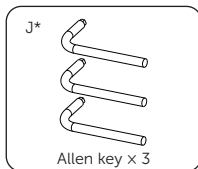
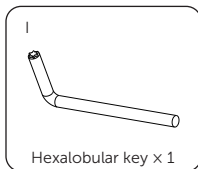
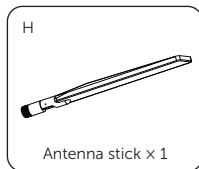
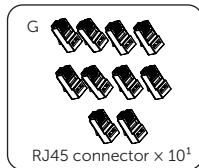
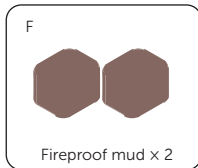
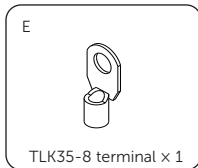
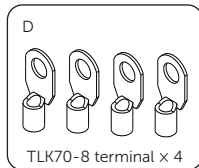
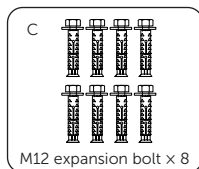
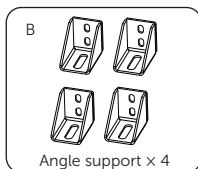
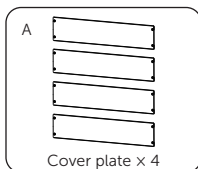
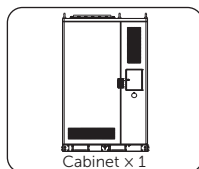

### NOTICE!

- "1" Reserved.
- The mark "\*" indicates that these keys are collected into a bunch.

### Installation Site

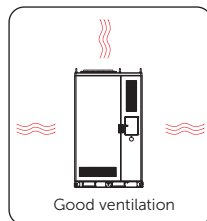
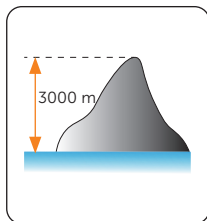
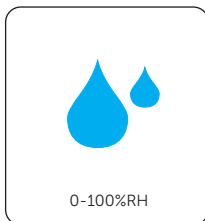
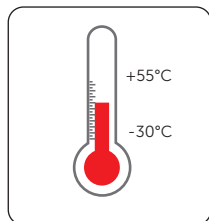



Installation Site	Distance
Distance from the device to the coast	> 2000 m
Distance from the device to the high heavily polluted area, for instance, smelting plant, coal mine, thermal power plant, etc.	> 1500 m
Distance from the device to the moderately polluted area, for instance, chemical plant, rubber plant, electroplate factory, etc.	> 1000 m
Distance from the device to the lightly polluted area, for instance, food factory, leather factory, heating boiler, slaughter house, dumping site, sewage treatment plant, etc.	> 500 m

## Transportation Requirement

### Forklift Requirement

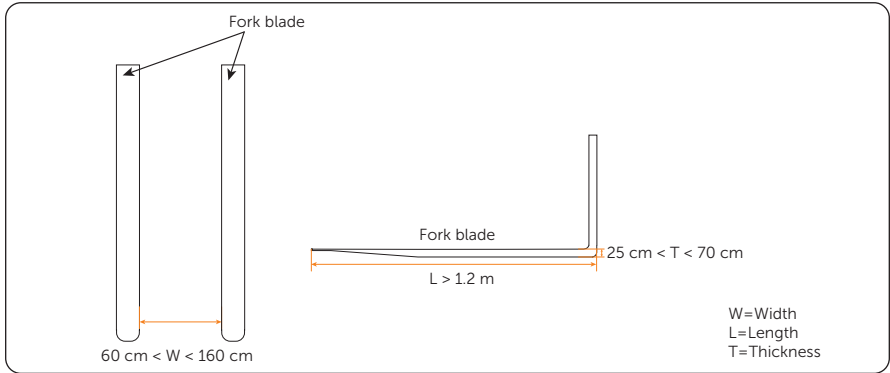

### Carton Fork Holes

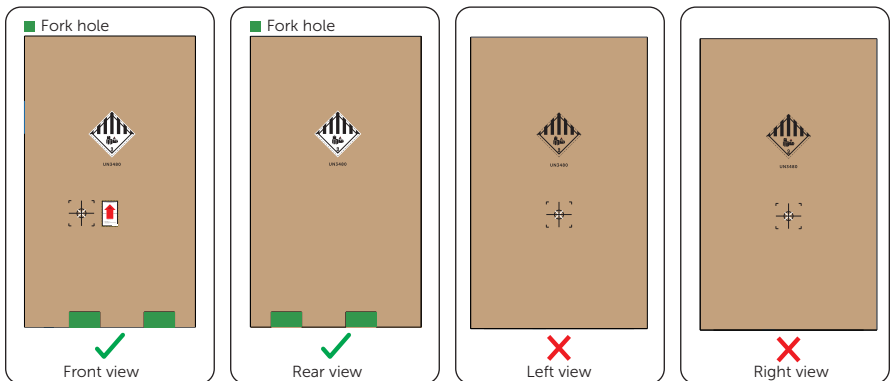

### Installation Carrier

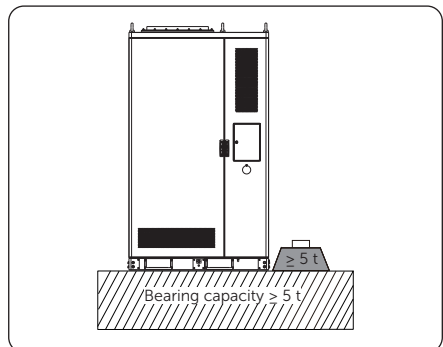
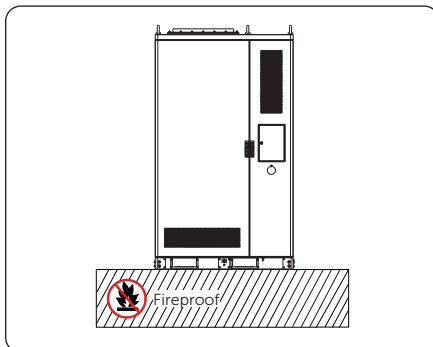

## Installation Space

### Clearance requirements for single cabinet:

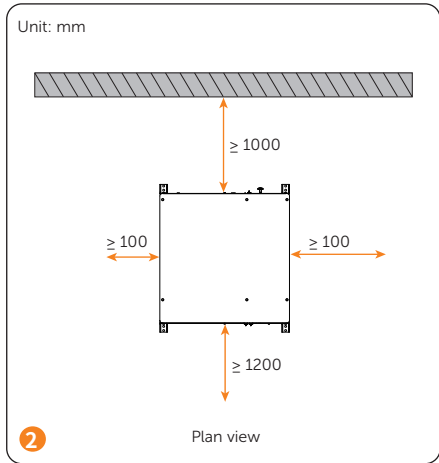
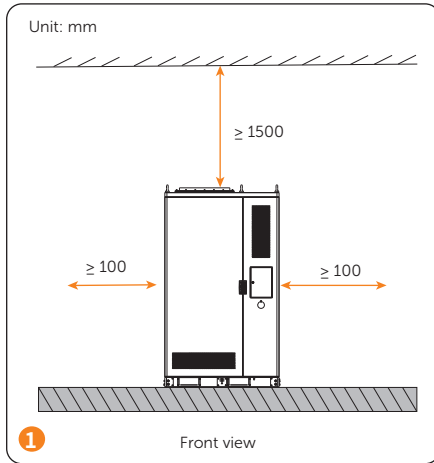

### Clearance requirements for multiple cabinets:

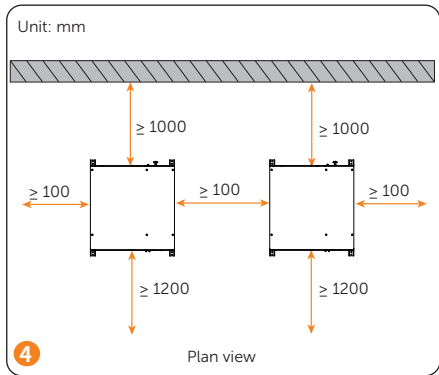
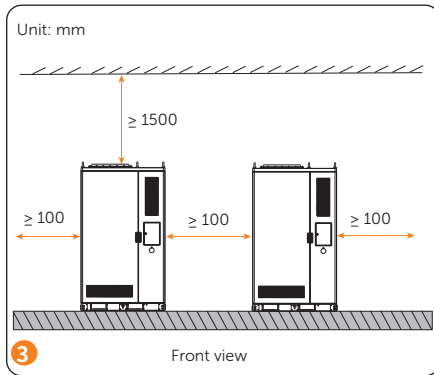



## Dimensions and Installation Foundation

### Angle supports installed at front and rear sides

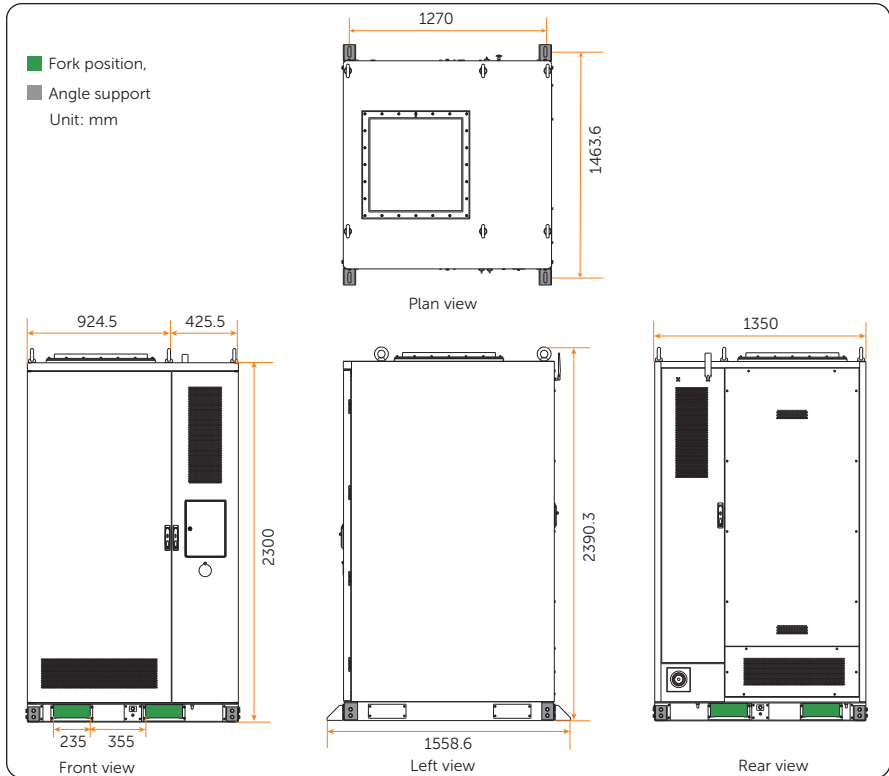

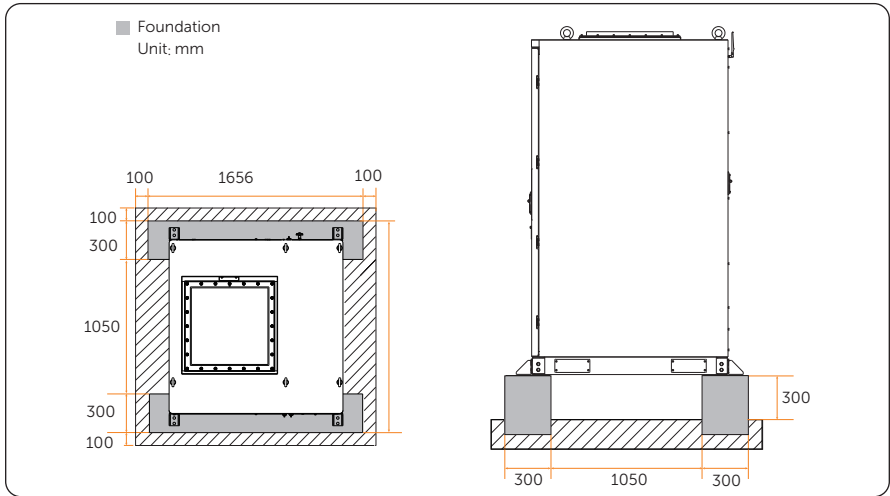

Angle supports installed at right and left sides

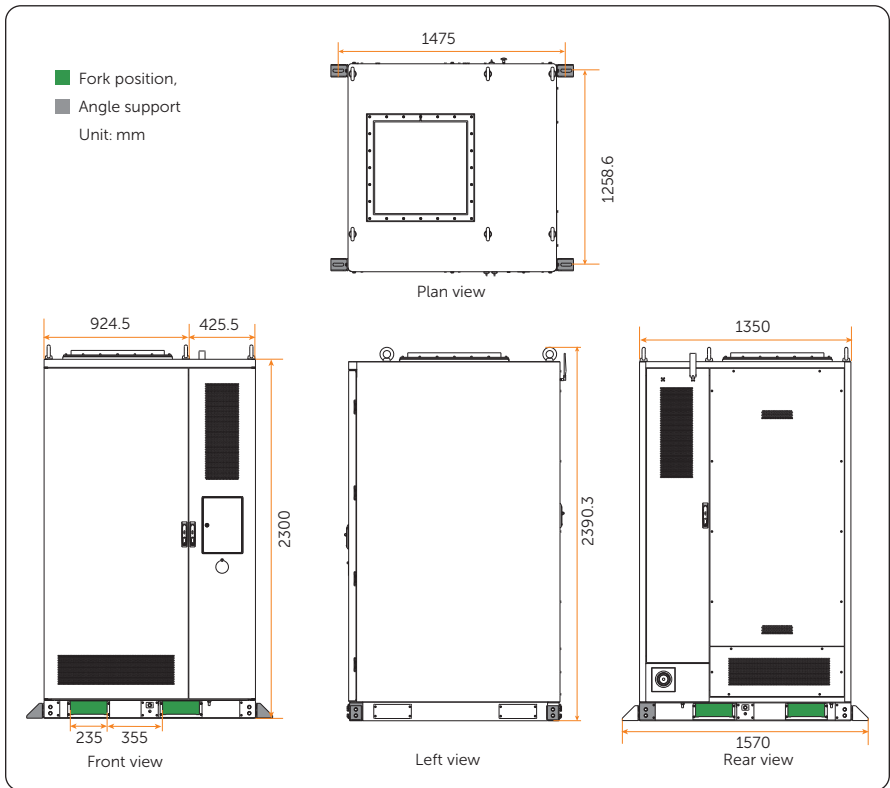

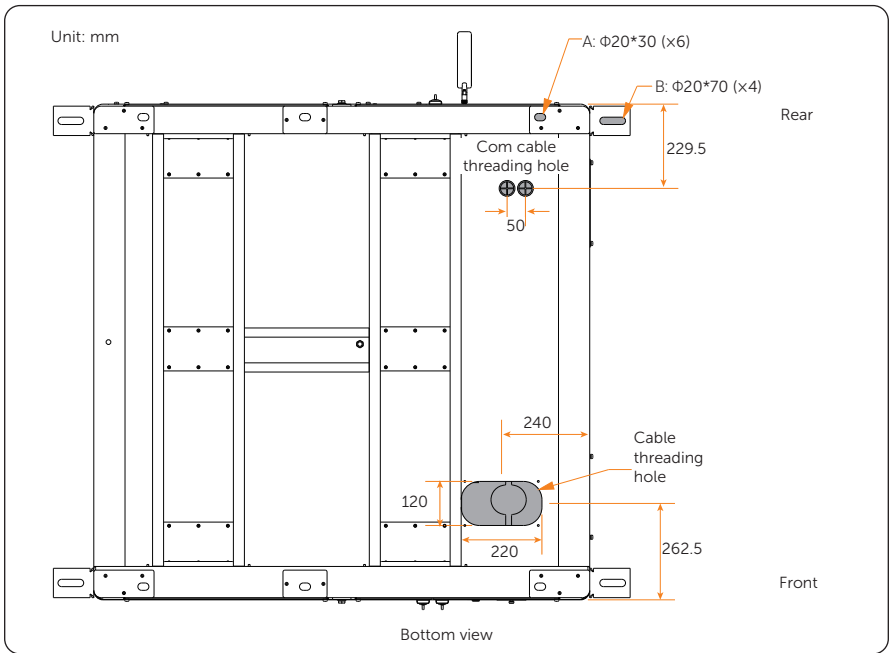
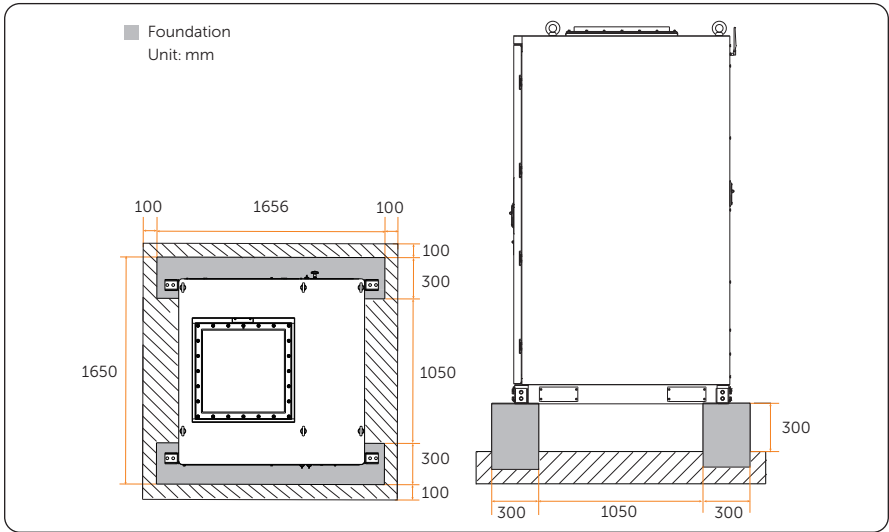

**NOTICE!**

- Secure the cabinet to the foundation through hole A or B.

## Steel foundation (Optional)

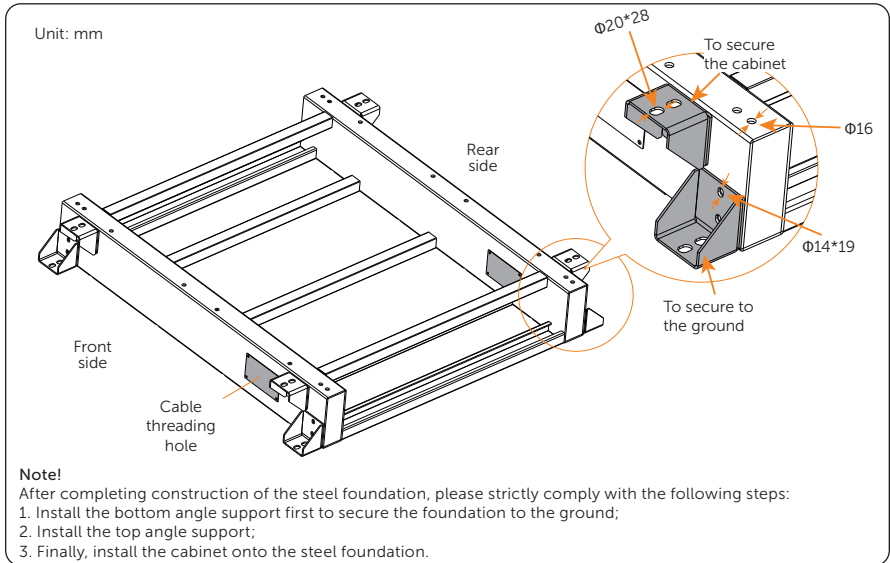
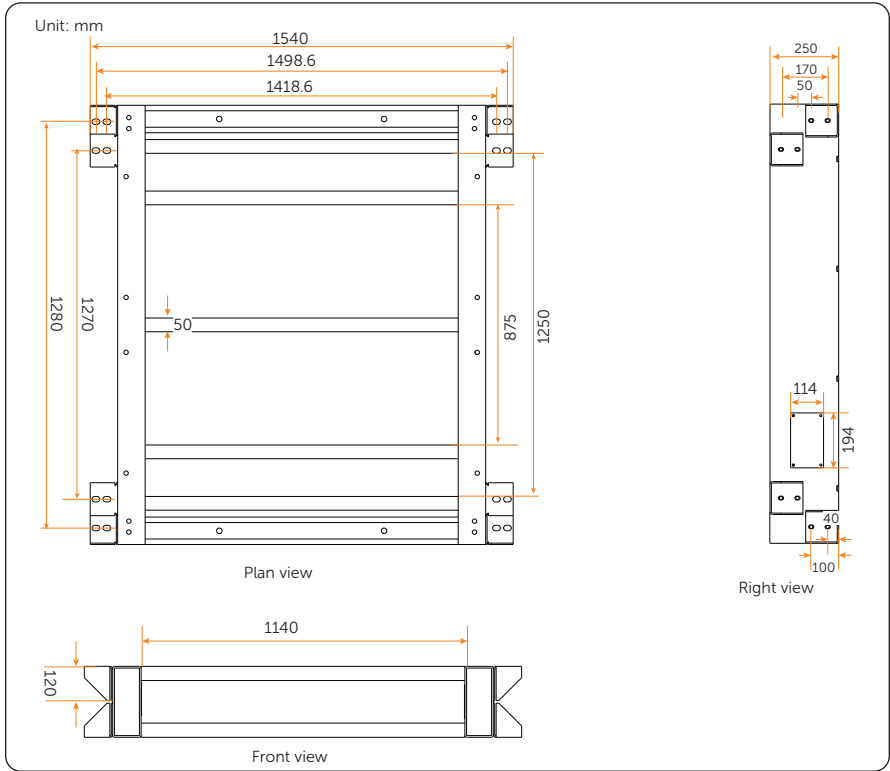

## Installation Tools

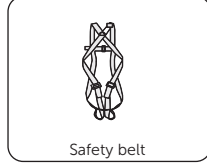
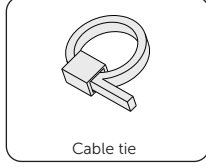
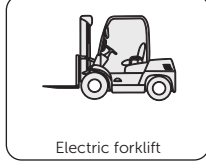
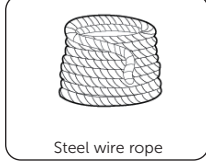
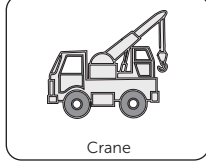
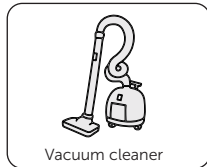
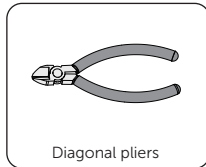
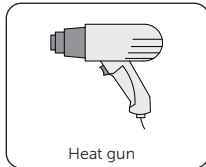
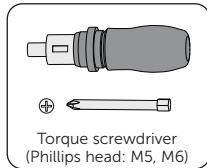
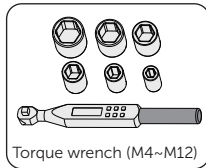
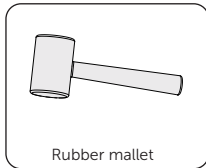
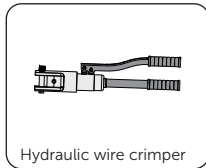
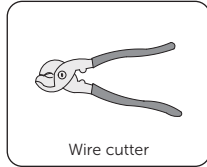
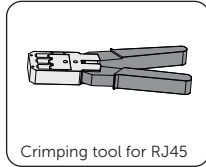
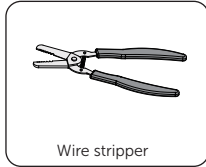
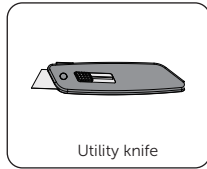
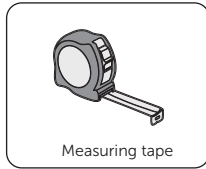
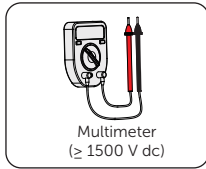
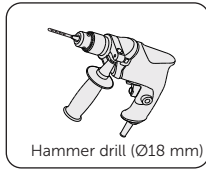

## Additionally Required Materials

No.	Required Material	Type	Specification
1	Grid cable 	Five-core copper cable (L1, L2, L3, N wire: 70 mm <sup>2</sup> PE wire: 35 mm <sup>2</sup> )	Conductor cross-section: 70 mm <sup>2</sup> *4 + 35mm <sup>2</sup> *1
2	Grounding plate 	Galvanized iron plate	Width: 40 mm Thickness: 4 mm
3	Ring terminal 	TLK50-12 or TLK70-12 ring terminal	 Inner diameter of cable conductor: TLK50-12: $\Phi 10 \pm 0.3$ mm TLK70-12: $\Phi 12 \pm 0.3$ mm
4	PE cable 	Conventional yellow and green wire	Conductor cross-section: 50mm <sup>2</sup> or 70mm <sup>2</sup>

### NOTICE!

- Select either grounding plate or ring terminal and PE cable to ground the cabinet.
- If you use wire rather than grounding plate for cabinet grounding, prepare PE wire and ring terminal of corresponding specification.

## Mechanical Installation



WARNING!

- Do not destroy the cabinet's anti-corrosion coating during the process of installation.

### Hoisting

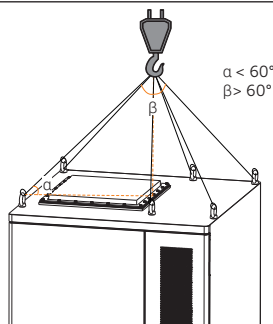
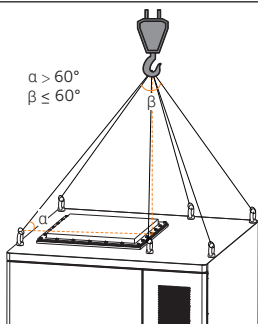

**Note!**

While hoisting, pay attention to the explosion vent, and ensure that the cabinet is horizontal and level.

### Lifting

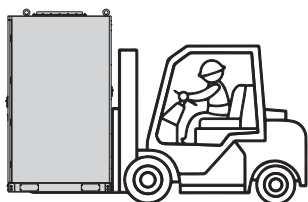

Left view

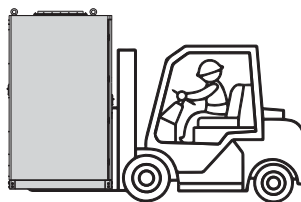

Right view

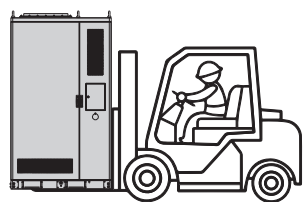

Front view

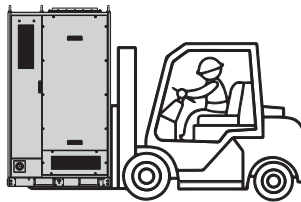

Rear view

## NOTICE!

- After unloading the cabinet from the forklift truck, check if there is any paint peeling or chipping. If there is, follow the instructions on the *User Manual* to repair.

## Installation of Angle support and Cover

## NOTICE!

- The installation steps of all four angle supports are the same. The following diagrams use only one of them for example.

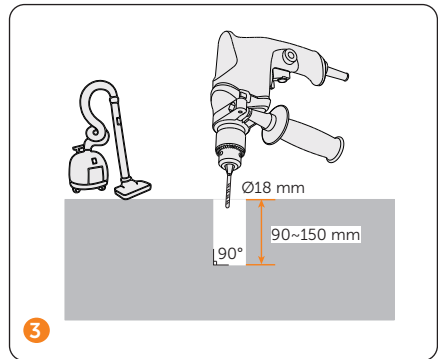
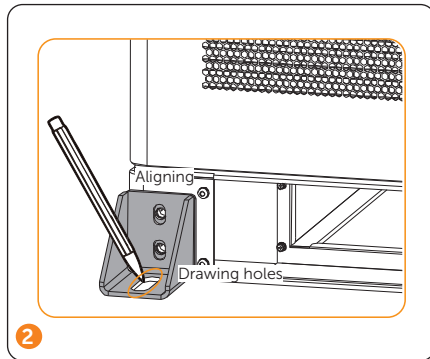
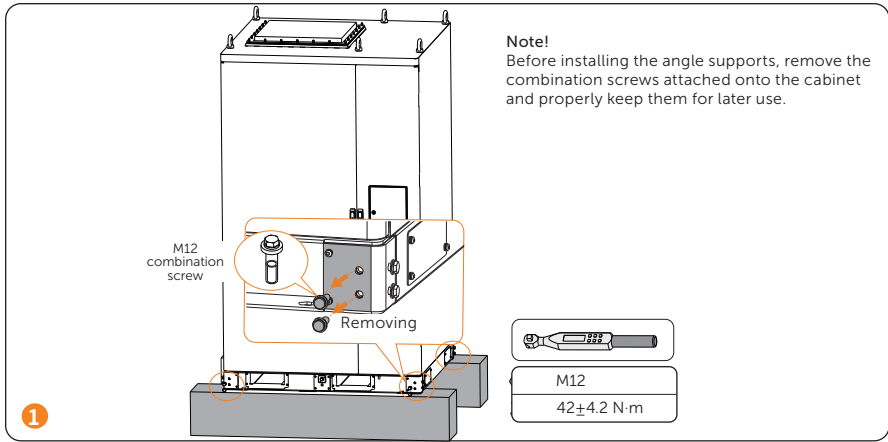



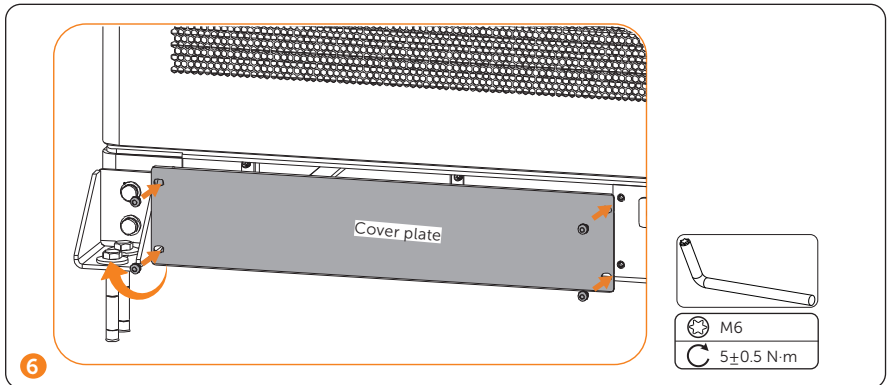
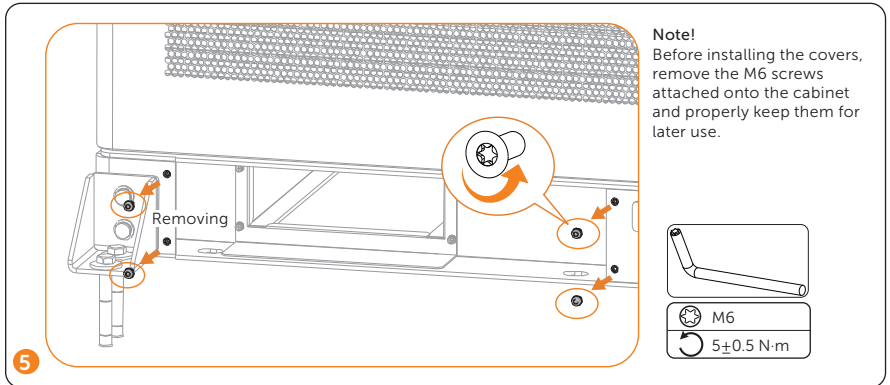
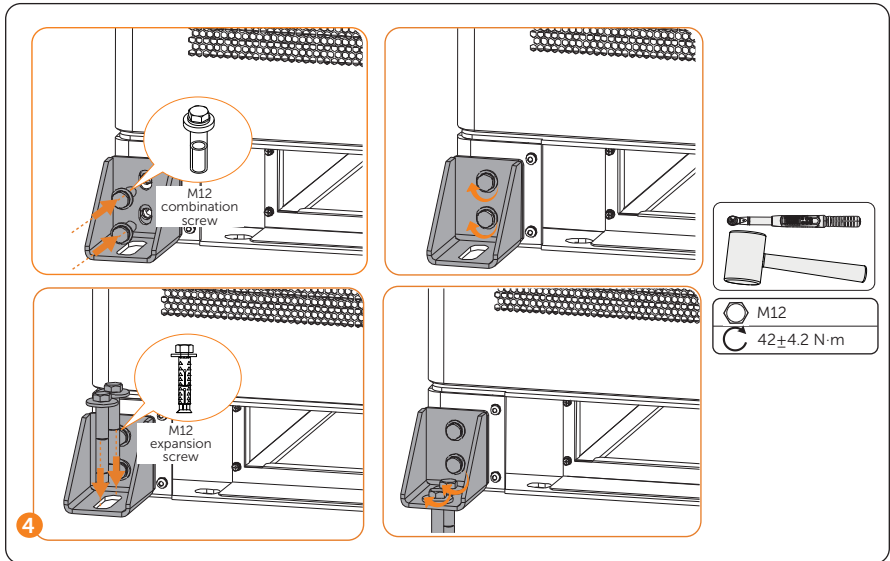

## Installation of Antenna

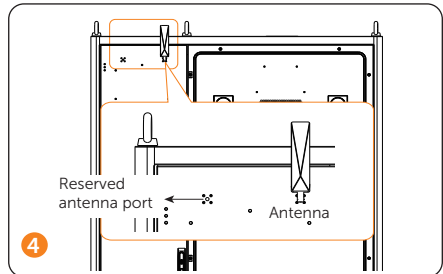
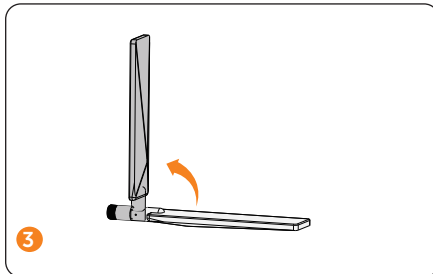
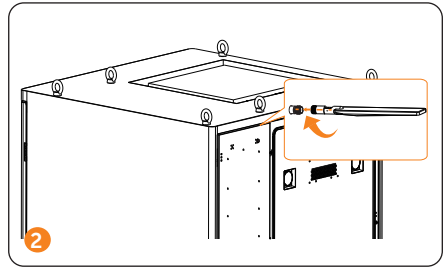
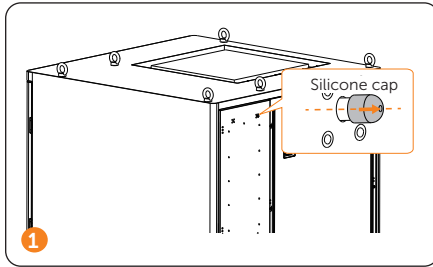

### NOTICE!

- An additional antenna terminal is available. The antenna connection procedure of this terminal is the same as the designated antenna terminal.
- Keep the sealing caps on if the antenna terminals are not used.

## Electric Connection

### Position of the Wired Parts

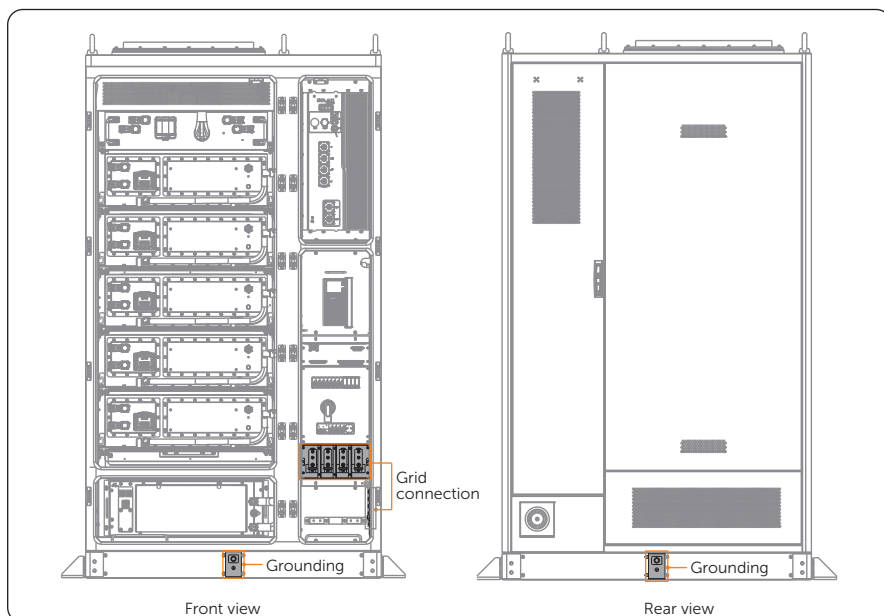

### Grounding Connection

The grounding terminals of the cabinet support both grounding plate and PE wire. Select either method to ground the cabinet.

Grounding plate connection:

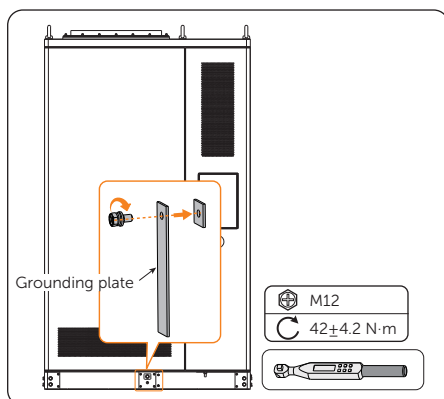

#### NOTICE!

- The cabinet offers 2 grounding terminals on the front and rear side. Select either terminal to perform grounding.
- This section uses the grounding terminal on the front side for example.

PE wire connection:

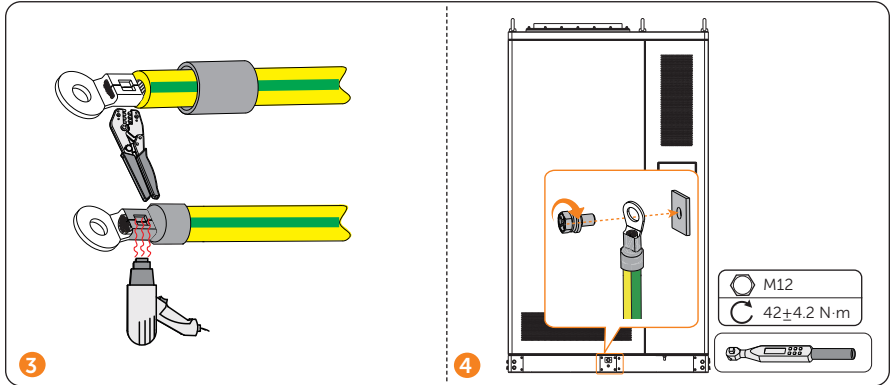
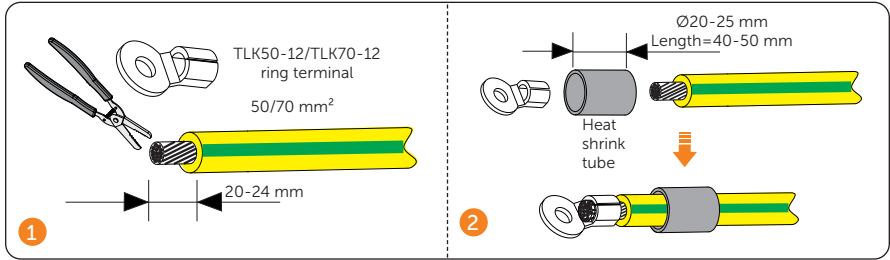

Grid Connection

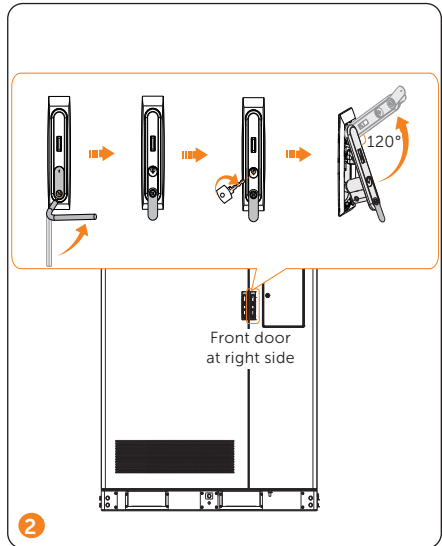
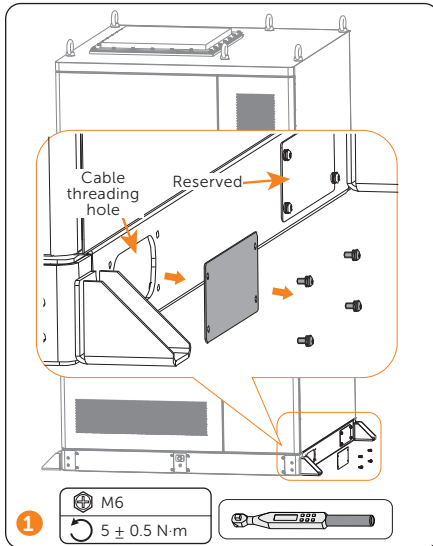

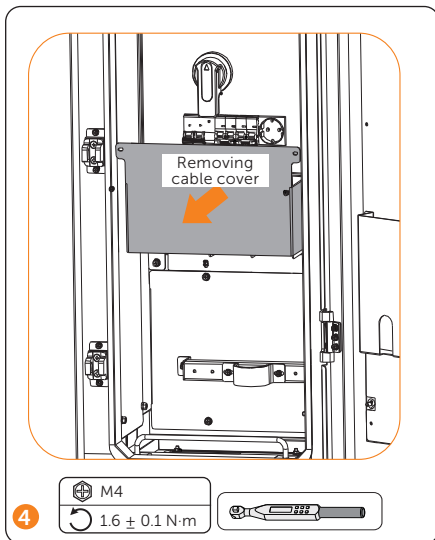
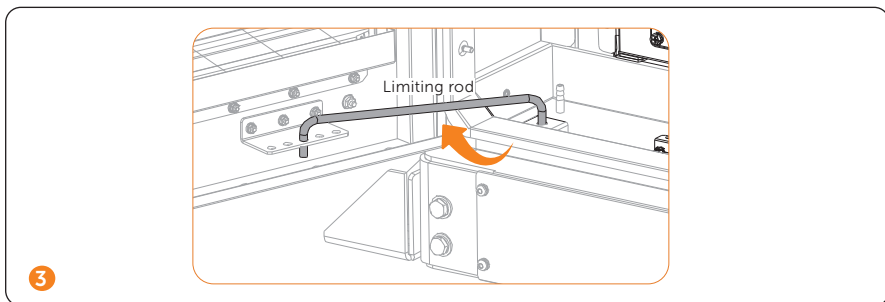

M4  
 $1.6 \pm 0.1 \text{ N}\cdot\text{m}$

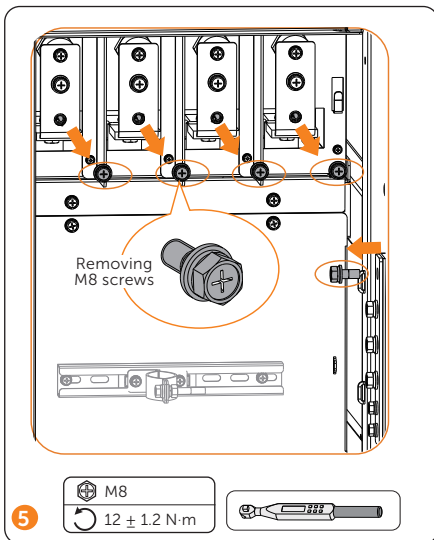

M8  
 $12 \pm 1.2 \text{ N}\cdot\text{m}$

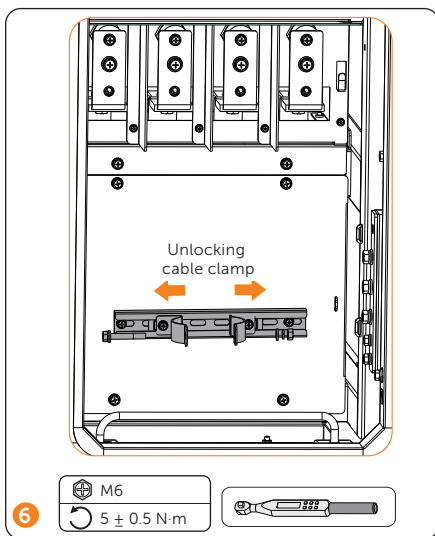
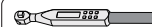

M6  
 $5 \pm 0.5 \text{ N}\cdot\text{m}$

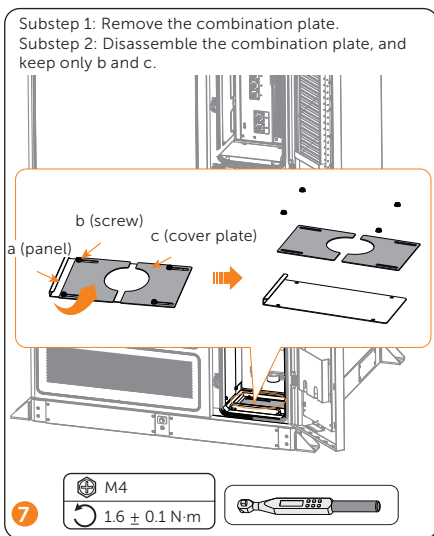

M4  
 $1.6 \pm 0.1 \text{ N}\cdot\text{m}$



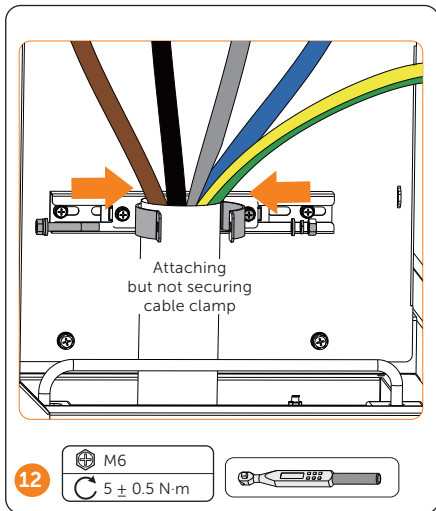
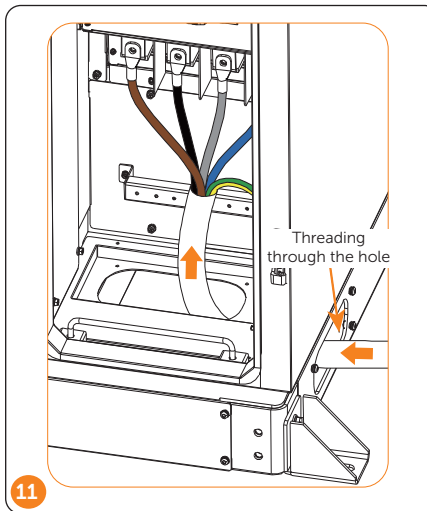
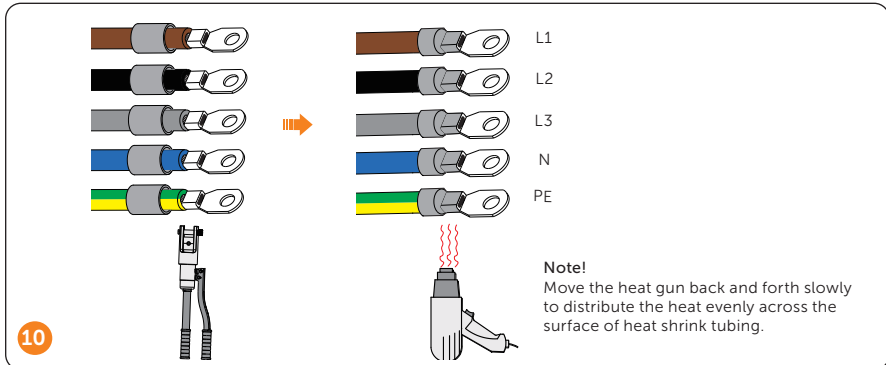
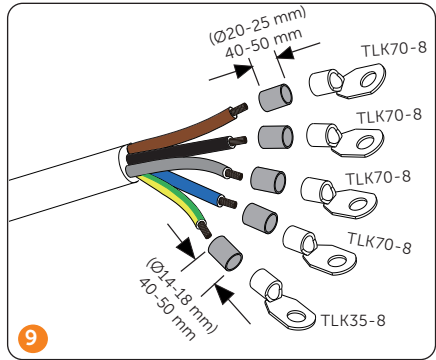
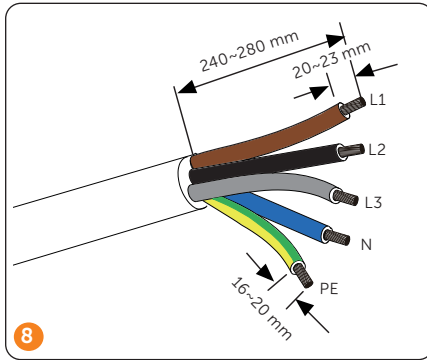

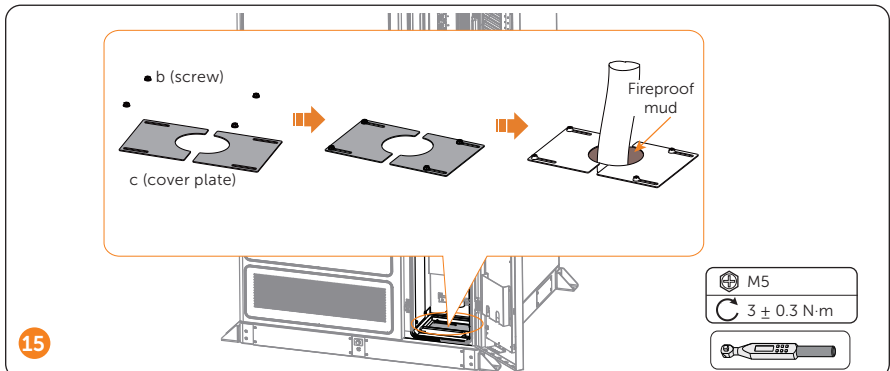
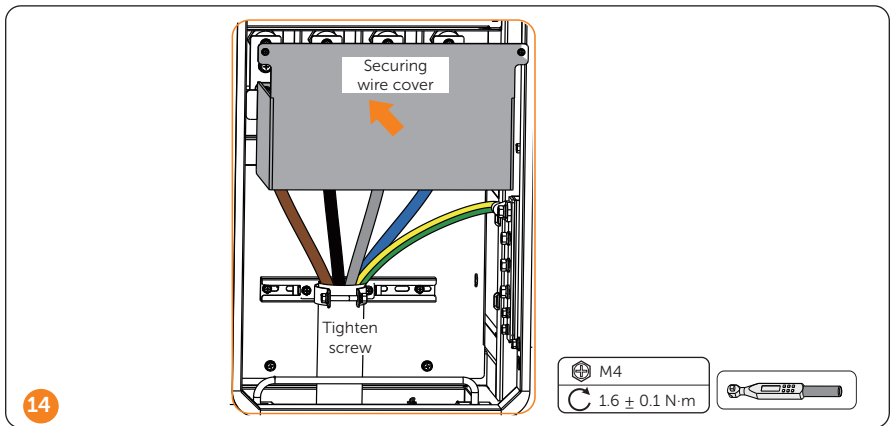
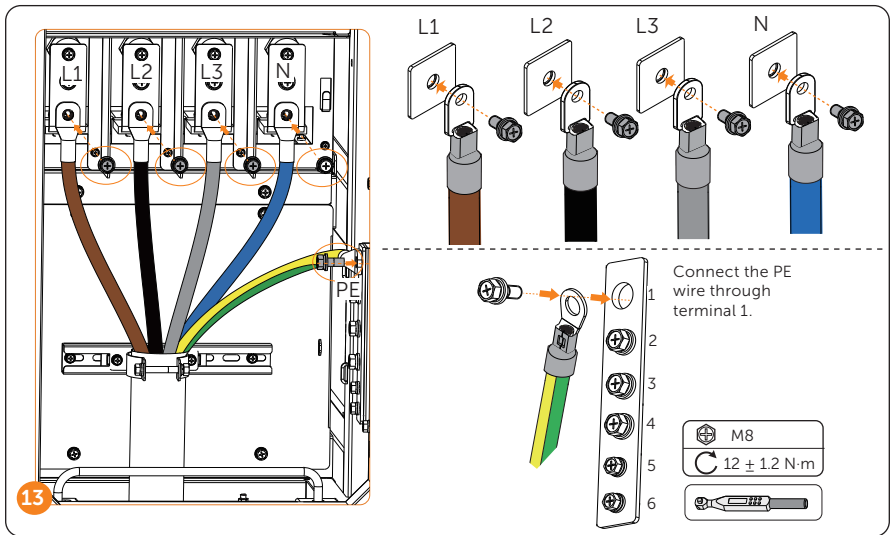

## NOTICE!

### Notice for fireproofing mud:

- Take out the fireproof mud delivered with the cabinet and knead it into a ball shape. In the case of the low temperature, place it into warm water, of which the temperature range is between 40°C and 70 °C, with its package until it is soft.
- Clean the area around the cable threading hole before sealing it.
- The fireproof mud should be evenly spread, embedded, or filled in the cable threading hole. If such a hole is too large, a fireproofing board can be placed to enhance fire protection before using the mud.
- The fireproof mud needs to be cured after sealing the cable threading hole. Prevent water from entering and colliding during curing.

## System Commissioning

### System Power-up

The position of components for powering on the system are as follows.

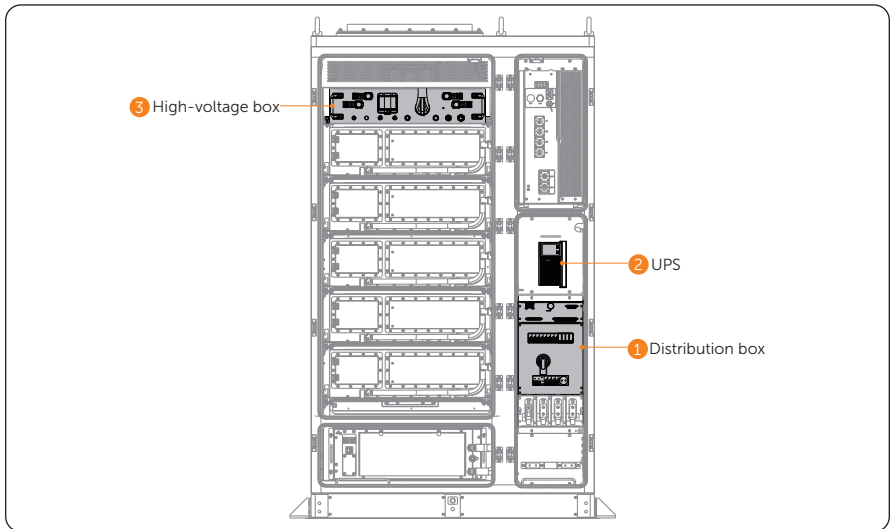

Strictly follow the steps to power on the system.

## NOTICE!

- Each time after turning on a component of the cabinet system, check its LED indicator status against "[LED Indicators](#)", and ensure that it work normally.



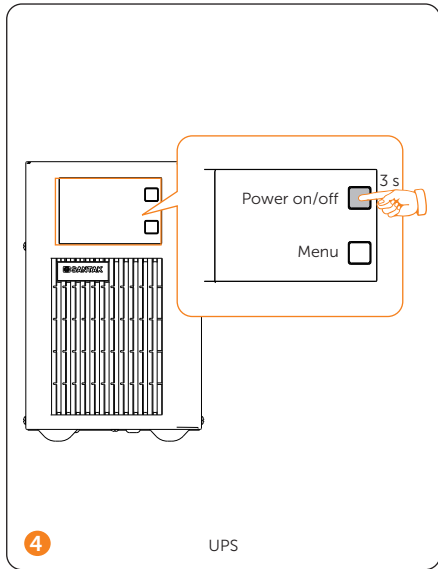
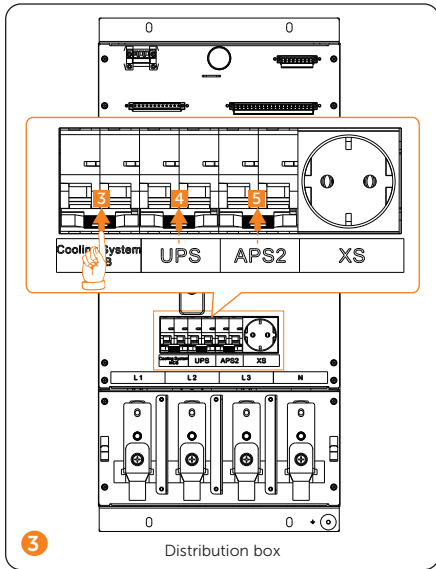
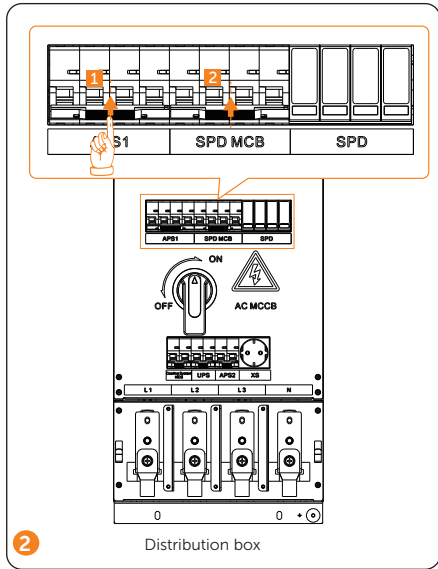
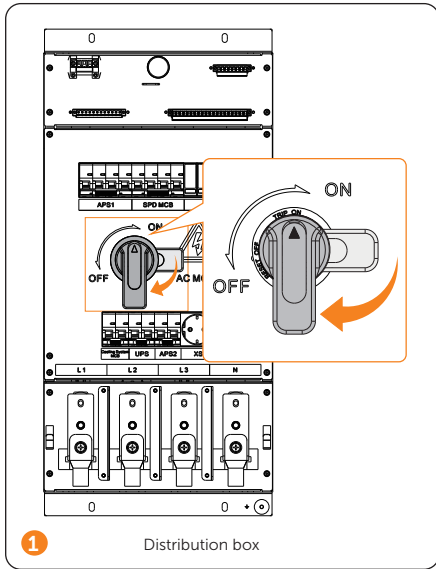

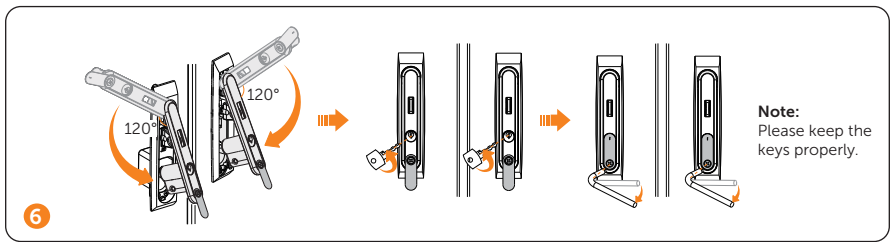
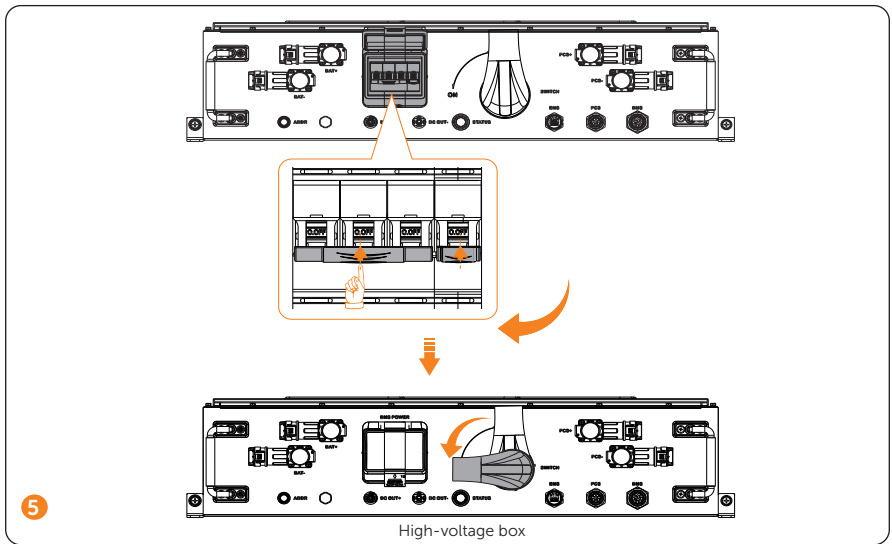

**NOTICE!**

- Make sure you have locked the doors well after normally powering on the system.

**EMS Configuration**

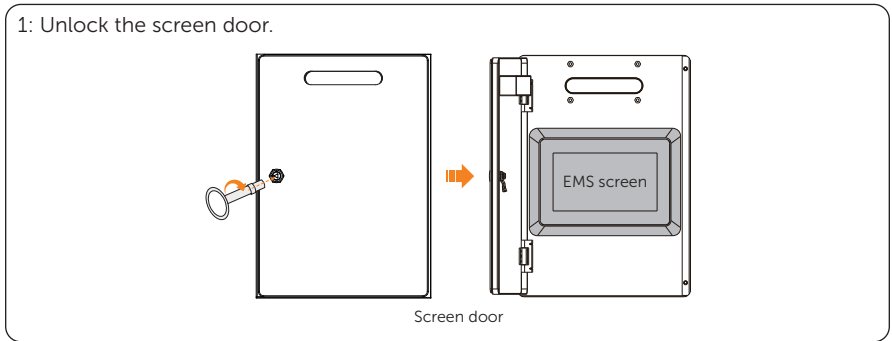

2: Log in to EMS.

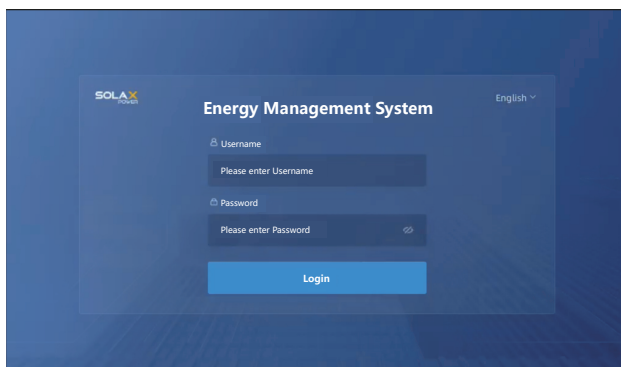

NOTICE	
Account information for logging in to EMS:	
Username	Initial Password
User	123456
EMS SN	
	

Username	Password
User	123456 by default

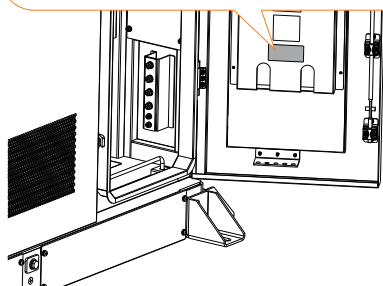

Position of EMS SN label

### NOTICE!

- Scan the SN QR code of EMS on the label pasted on the bottom of the cabinet door interior, or log in to EMS through the user account, and then go to **Data > EMS > EMS Registration No.** to obtain the SN.

## SolaXCloud Download



Scan the QR code to download SolaXCloud App. Follow the tutorial or online documents on the SolaXCloud App to complete the configuration.

## LED Indicators

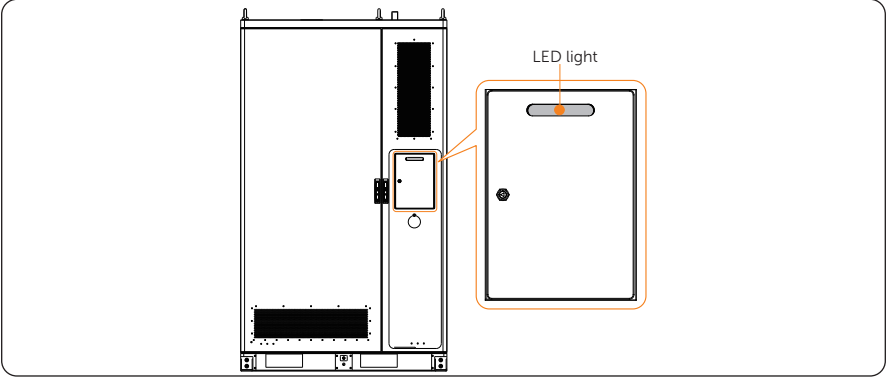

### Cabinet's LED Indicator Light



Indicator Light Status	Definition
Solid yellow	Standby
Solid green	Running
Solid red	Fault

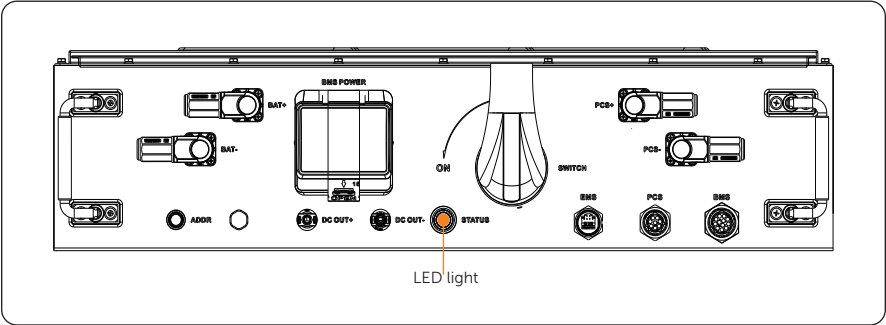





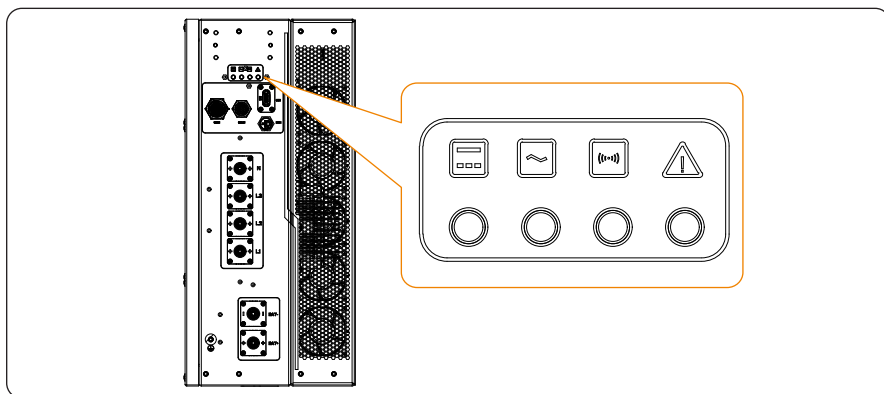

### High-voltage Box's LED Indicator Light











Indicator Light Status		Description
Solid green		Powered on
Blinking green		Running
Solid red		Fault

### PCS's LED Light







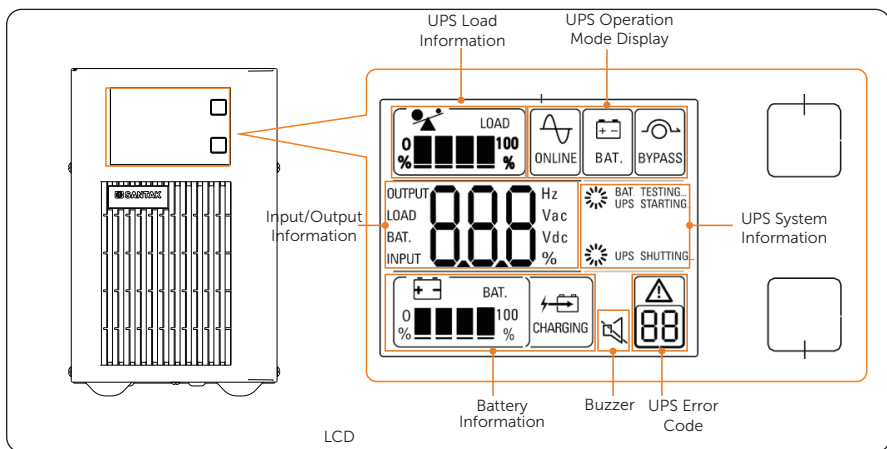

LED indicator	Status	Definition
	 Light on	PCS on-grid operation
	 Blinking slow (Every 1.4s)	BMS failure
 DC	 Blinking fast (Every 0.3s)	When the red light is on, there is a DC side fault of the PCS When the red light is off, the DC side battery status of the PCS is normal
	 Light off	DC not connected on battery side
	 Light on	PCS on-grid operation
 AC	 Blinking fast (Every 0.3s)	When the red light is on, there is a fault on the AC side of the PCS; When the red light is off, the AC side grid status of the PCS is normal;
	 Light off	Grid not connected

LED indicator	Status	Definition
	 Light on	Monitoring communication normal, BMS communication normal
 COMM	 Blinking slow (Every 1.4s)	BMS communication abnormal
	 Blinking fast (Every 0.3s)	Monitoring communication abnormal
 FAULT	 Light on	The PCS is in a fault state.
	 Blinking	The PCS is in aging mode.
	 Light off	The PCS is normal.

### UPS's LCD



Display	Description
Input/Output Information	It indicates input and output voltage/frequency value, which are displayed alternately. It also indicate load per cent and battery voltage value.
UPS Operation Mode Display	It indicates UPS operating mode.
Load information	Indicates the load level. Each grid represents the level of 25%. If UPS is overloaded, the icon  would flash once time per second.

Display	Description
Battery Information	Indicates the battery capacity. Every grid represents the capacity of 25%. If the battery charger is running, the icon  would show.
Buzzer	 The icon will be displayed after panel key operation or serial command mute.  The icon will be displayed when the buzzer sounds normally.
UPS Error Code	<p>Indicates the UPS is in Fault mode or has some warnings. Indicates Fault kind or Warning kind, several warning kinds at the same time could be displayed alternately.</p> <p>The icon  would flash when having warnings.</p> <p>The icon  would show continuous when in Fault mode.</p>
UPS System Information	Indicates UPS system information

## System Decommissioning

There are two circumstances for system power-off: 1. Normal power off; 2. Emergency power off.

### Normal Power Off

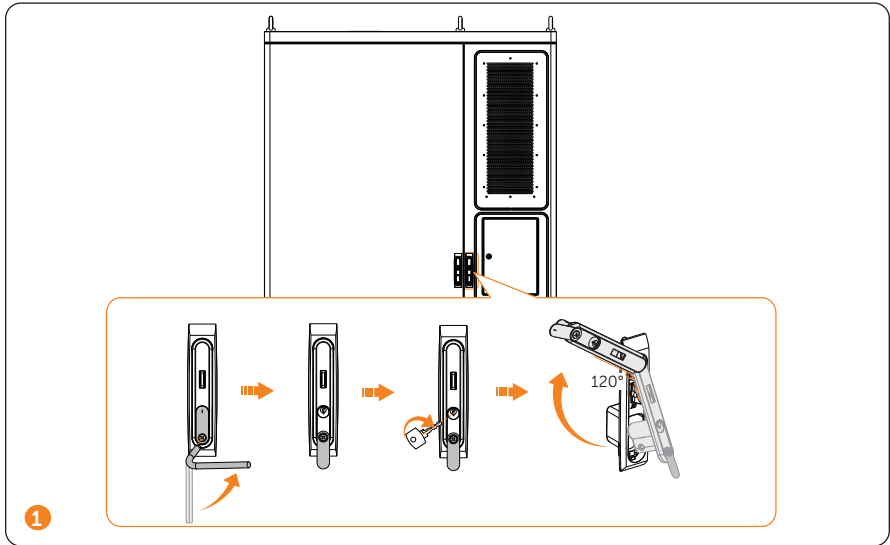

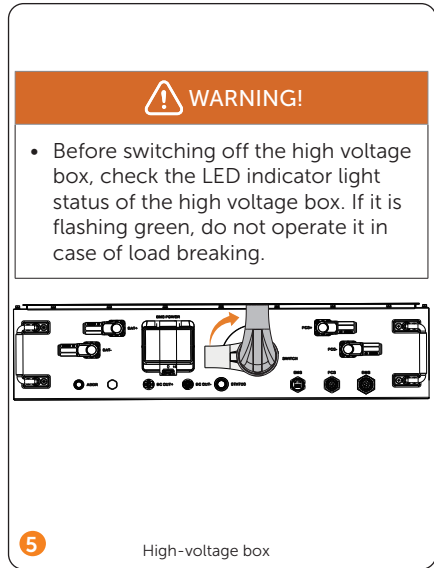
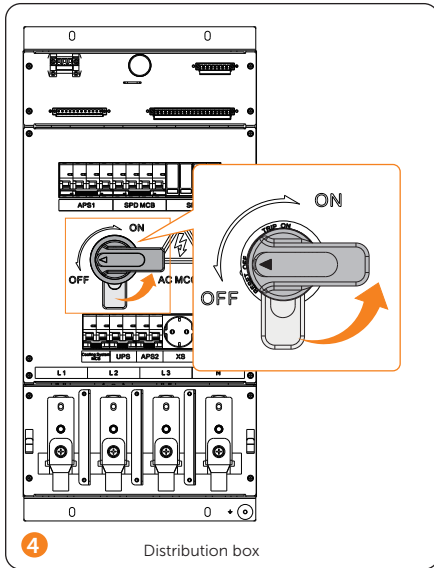
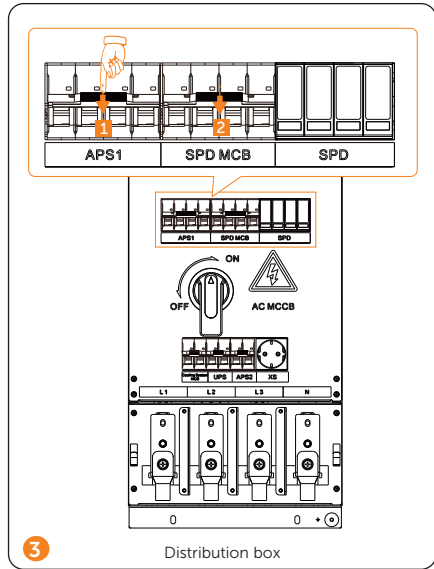
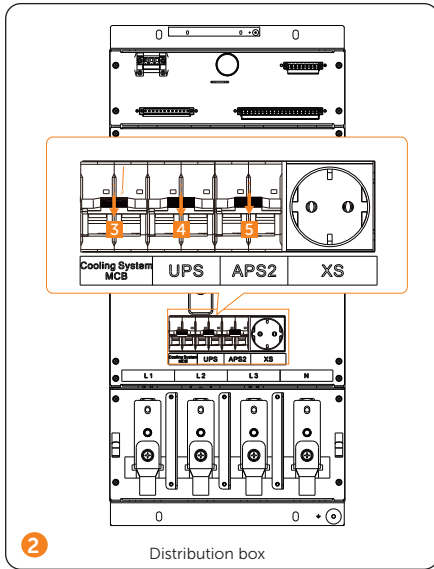

**WARNING!**

- Before switching off the high voltage box, check the LED indicator light status of the high voltage box. If it is flashing green, do not operate it in case of load breaking.



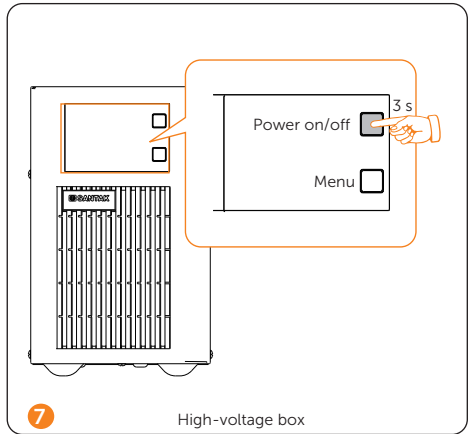
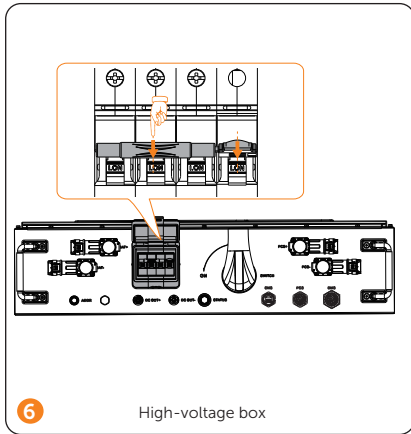

### Emergency Power Off

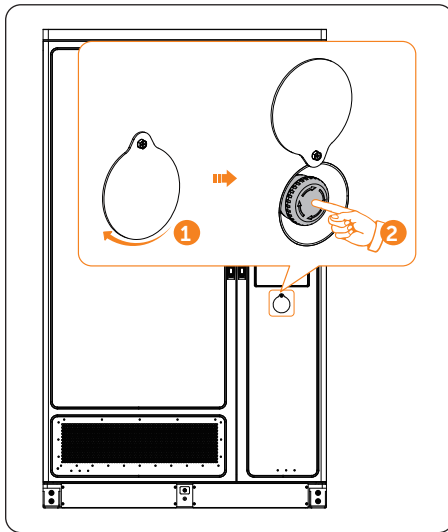

### ! WARNING!

Do not press the emergency stop button unless in an emergency.

#### Note!

If the emergency stop button has ever been pressed down, it must be reset before you power the system next time. The resetting procedure is as follows:

1. Rotate up the cover;
2. Rotate the button according to the arrow direction shown on the button, and then the button will spring back to its original position.

## Technical Data



Model	TRENE- P79B261L-E	TRENE- P100B261L-E	TRENE- P124B261L-E	TRENE- P125B261L-E
Rated AC Voltage	3 / N / PE, 230 / 400 V			
Charging/Dis- charging Power	79.9 kW	100 kW	124.9 kW	125 kW
Rated Grid Frequency	50/60 Hz (According to local regulations)			
Max. AC Current	127.4 a.c. A	159.5 a.c. A	199.2 a.c. A	199.3 a.c. A
Conditional Short-circuit Current (I <sub>cc</sub> )	< 10000 A			
Output Short Circuit Current	560 A			
Auxiliary Power Input Voltage	L / N / PE, 230 a.c. V			
Auxiliary Power Input Current	10 a.c. A			
Auxiliary Power Frequency	50/60 Hz			
Operating Temperature	-30°C to +55°C			
Protective Class	I			
Altitude	Below 3000 m			
Ingress Protection	IP55			

# Contact Information



## UNITED KINGDOM



---

 Unit C-D Riversdale House, Riversdale Road, Atherstone, CV9 1FA  
 +44 (0) 2476 586 998  
 service.uk@solaxpower.com



## TURKEY



---

 Fevzi Çakmak mah. asım cd. no 88 A Karatay / Konya / Türkiye  
 service.tr@solaxpower.com



## USA

---

 3780 Kilroy Airport Way, Suite 200, Long Beach, CA, US 90806  
 +1 (408) 690 9464  
 info@solaxpower.com



## POLAND



---

 WARSAW AL. JANA P. II 27. POST  
 +48 662 430 292  
 service.pl@solaxpower.com



## ITALY

---

 +39 011 19800998  
 support@solaxpower.it



## PAKISTAN



---

 service.pk@solaxpower.com



## AUSTRALIA





---

 21 Nicholas Dr, Dandenong South VIC 3175  
 +61 1300 476 529  
 service@solaxpower.com.au



## GERMANY





---

 Am Tullnaupark 8, 90402 Nürnberg, Germany  
 +49 (0) 6142 4091 664  
 service.eu@solaxpower.com  
 service.dach@solaxpower.com



## NETHERLANDS



---

 Twekkeler-Es 15 7547 ST Enschede  
 +31 (0) 8527 37932  
 service.eu@solaxpower.com  
 service.bnl@solaxpower.com



## SPAIN



---

 +34 9373 79607  
 tecnico@solaxpower.com



## BRAZIL

---

 +55 (34) 9667 0319  
 info@solaxpower.com



## SOUTH AFRICA

---

 service.za@solaxpower.com



# Warranty Registration Form



## For Customer (Compulsory)

Name ..... Country .....

Phone Number ..... Email .....

Address .....

State ..... Zip Code .....

Product Serial Number .....

Date of Commissioning .....

Installation Company Name .....

Installer Name ..... Electrician License No. ....

## For Installer

### Module ( If Any )

Module Brand .....

Module Size(W) .....

Number of String ..... Number of Panel Per String .....

### Battery ( If Any )

Battery Type .....

Brand .....

Number of Battery Attached .....

Date of Delivery ..... Signature .....

Please visit our warranty website: <https://www.solaxcloud.com/#/warranty> or use your mobile phone to scan the QR code to complete the online warranty registration.



For more detailed warranty terms, please visit SolaX official website: [www.solaxpower.com](http://www.solaxpower.com) to check it.





**SolaX Power Network Technology (Zhejiang) Co., Ltd.**

Add.: No. 278, Shizhu Road, Chengnan Sub-district, Tonglu County,  
Hangzhou, Zhejiang, China  
E-mail: [info@solaxpower.com](mailto:info@solaxpower.com)

